

POWRMATIC®

Eeco-X

User, Installation & Servicing Manual

Issue 1.1 Sept 2025

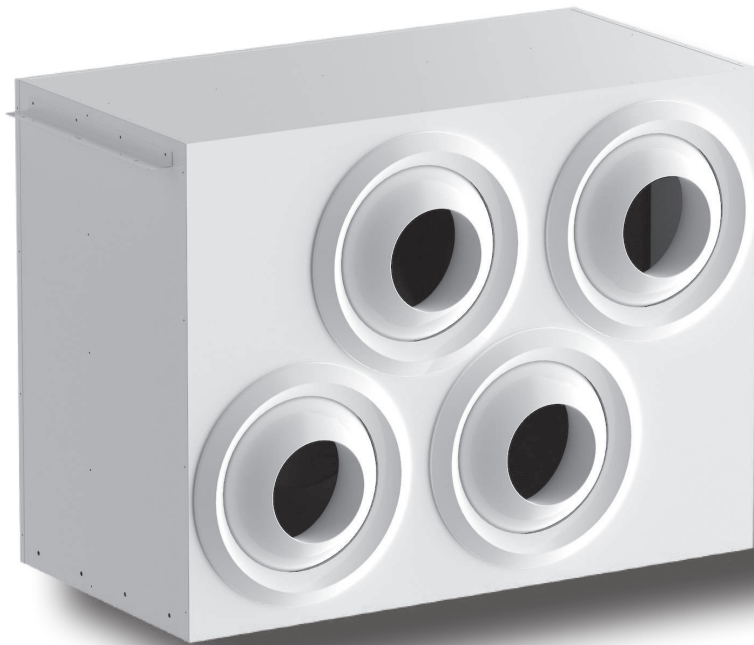

Dear Customer - thank you for choosing Powrmatic.

We appreciate you buying one of our high quality products and know that you have made the best choice. By choosing Powrmatic, you are investing in UK manufacturing & its workforce. We pride ourselves by manufacturing products that provide clean, comfortable and safe working environments worldwide together with the personal & professional service and back-up you deserve. If you have any questions or concerns regarding this product, please contact our Technical Support Team by calling 01460 53535.

This booklet consists of 60 pages.

Conformity

This unit complies with the European directives:

- Low Voltage Directive 2014/35/EU by transposition of the following technical standards: EN 60335-1:2012 + EN 60335-2-40:2003
- EMC Directive 2014/30/EU, through transposition of the technical standards: EN 55014-1:2017 + EN 55014-2:2015 + EN 61000-3-2:2014 + EN 61000 3-3:2013
- RoHS2 Directive 2011/65/EU2 on the restriction of the use of hazardous substances in electrical and electronic equipment
- Directive 2012/96/EC (WEEE) on waste electrical and electronic equipment
- F-Gas Regulation 2014/517/EU on fluorinated greenhouse gases
- European ErP Ecodesign Regulation No. 1254/2014 And subsequent amendments.

Markings



Contents

CONTENTS

Compliance	3	6.2 First start-up	39
1. General information	5	6.3 Plant delivery	40
1.1 About the manual	5	6.4 Switching off for extended periods	40
1.2 General warnings	6	6.5 Control settings.	41
1.3 Basic safety rules.	6	7. Maintenance	48
1.4 Disposal	7	7.1 Routine maintenance	48
2. Product introduction	8	8. Decommissioning	50
2.1 Identification	8	8.1 Safety warnings	50
2.2 Destination of use	8	9. Faults and remedies	51
2.3 Description of the appliance	8	9.1 Preliminary warnings	51
2.4 List of external components	9	9.2 Anomalies reported by the control panel	51
2.5 List of internal components	10	9.3 Functional aspects not to be interpreted as faults	51
2.6 Configurations	11	9.4 Troubleshooting table.	52
2.7 Compatible accessories	13	9.5 Alarms displayed on the control panel of the external unit	52
3. Installation	14	10. Technical information	55
3.1 Preliminary warnings	14	10.1 Technical data.	55
3.2 Reception	14	10.2 Fuse Characteristics	57
3.3 Dimensions and weights with packaging	14	10.3 Dimensions	58
3.4 Handling with packaging	15	10.4 Indoor Unit Throws	59
3.5 Storage.	15		
3.6 Unpacking.	15		
3.7 Handling without packaging.	16		
3.8 Installation site.	16		
3.9 Minimum installation distances.	17		
3.10 Positioning	19		
3.11 Refrigeration connections	20		
3.12 Condensate drain connection	24		
3.13 Aeraulic connections.	26		
3.14 Electrical connections	27		
4. Remote control	34		
4.1 Installation	34		
4.2 Electrical connections	35		
4.3 Interface	36		
5. Control panel - Menu structure	37		
5.1 Overview of the structure	37		
5.2 Details of the structure	37		
6. Start-up	39		
6.1 Preliminary warnings	39		

1. GENERAL INFORMATION

1.1 About the manual

This manual was written to provide all the explanations for the correct management of the appliance.

- ⚠ This instruction manual is an integral part of the appliance and must therefore be kept in a safe place and must ALWAYS accompany the appliance even if it is passed on to another owner or user, or transferred to another plant. If it is damaged or lost, download a copy from the website.
- ⚠ Read this manual carefully before proceeding with any operation and follow the instructions in the individual chapters.
- ⚠ Specific warnings are given in each chapter of the document and should be read before starting operations.
- ⚠ The manufacturer accepts no liability for damage to persons or property resulting from failure to observe the regulations contained in this booklet.
- ⚠ This document is confidential under the terms of the law and may not be reproduced or passed on to third parties without the express authorisation of the Manufacturer.

Editorial pictograms

The pictograms in the following chapter provide quick and unambiguous information necessary for the correct and safe use of the machine.

Related to safety

⚠ High risk warning (bold text)

- The operation described above presents a risk of serious physical injury, fatality, major damage to the appliance and/or to the environment if not carried out in compliance with safety regulations.

⚠ Low risk warning (plain text)

- The operation described above presents a risk of minor physical injury or minor damage to the appliance and/or to the environment if not carried out in compliance with safety regulations.

⊘ Prohibition (normal text)

- Marks actions that are prohibited.

ⓘ Important information (bold text)

- This indicates important information that must be taken into account during the operations.

In the texts

Purpose of the actions

- ▶ Actions required

Expected responses following an action

- Lists

In the figures

- 1 The numbers indicate the individual components.

A Capital letters indicate a combination of components and dimensions.

- ① The white numbers in black marks indicate a series of actions to be carried out in sequence.

- Ⓐ The black letter in white identifies an image when there are several images in the same figure.

Pictograms on the product

Symbols are used in some parts of the appliance:

Related to safety



Read the instruction manual

Read the instructions carefully before performing any operation on the appliance.



Instruction manual

Read the information available in the technical documentation of the appliance.



Attention electrical hazard

- Warns relevant personnel of the presence of electricity and the risk of electric shock.

Recipients

User

Non-expert person capable of operating the product in safe conditions for people, for the product itself and the environment, interpreting an elementary diagnostic of faults and abnormal operating conditions, carrying out simple adjustment, checking and maintenance operations.

Installer

Expert person qualified to position and connect (hydraulically, electrically, etc.) the unit to the plant; this person is responsible for handling and correct installation according to the instructions provided in this manual and the national standards currently in force.

Service

Expert and qualified person authorised directly by the Manufacturer to carry out all routine and supplementary maintenance operations, as well as every adjustment, check, repair and replacement of parts necessary during the life of the unit.

Organisation of the manual

The manual is divided into sections each dedicated to one or more target groups.

General information

It addresses all recipients.

It contains general information and important warnings that should be known before installing and using the appliance.

Product introduction

General

Addressed to all recipients, contains general information on the product.

Installation and Operation

It is addressed exclusively to the installer.

Contains specific warnings and all information necessary for positioning, mounting, connecting the device and operation.

Commissioning, maintenance and troubleshooting

They are addressed exclusively to the Authorised Service Centre.

It contains specific warnings and useful information for the most common commissioning and routine maintenance.

Decommissioning

It is addressed solely and exclusively to the Authorised Service Centre.

Technical information

It addresses all recipients.

It contains detailed technical information about the appliance.

1.2 General warnings

- ⚠ Specific warnings are given in each chapter of the document and should be read before starting operations.
- ⚠ All personnel involved must be aware of the operations and dangers that may arise when beginning all unit installation operations.
- ⚠ Installation performed outside the warnings provided in this manual and use of the appliance outside the prescribed temperature limits will invalidate the warranty.
- ⚠ Any contractual or extra-contractual liability for damage caused to persons, animals or property, due to installation, adjustment and maintenance errors or improper use is excluded. All uses not expressly indicated in this manual are not permitted.
- ⚠ The installation of the appliances must be carried out by a qualified company which, on completion of the work, will issue a declaration of compliance to the person in charge of the plant in accordance with the regulations in force and the instructions provided in the instruction booklet accompanying the appliance.
- ⚠ First start-up and repair or maintenance operations must be carried out by the Authorised Service Centre or by qualified personnel following the provisions of this manual.
- ⚠ Do not modify or tamper with the appliance as this can lead to dangerous situations.
- ⚠ Use suitable personal protective clothing and equipment during installation and/or maintenance operations. The Manufacturer is not liable for the non-observance of the current safety and accident prevention regulations.
- ⚠ In case of liquid or oil leaks, isolate the main power supply of the system and close any water valves. Promptly contact the Authorised Service Centre or professionally qualified personnel, and refrain from personally intervening on the equipment.
- ⚠ When replacing components, use only original spare parts.
- ⚠ The Manufacturer reserves the right to make changes to its models at any time to improve its product, without prejudice to the essential characteristics described

in this manual. The Manufacturer is not obliged to add such modifications to machines previously manufactured, already delivered, or under construction.

- ⚠ The appliance can be used by children aged 8 years and above and by persons with reduced physical, sensory, or mental capabilities, or those lacking experience or necessary knowledge, provided they are under supervision or have been given instructions concerning the safe use of the appliance and understand the hazards involved. Children should not play with the appliance. Cleaning and maintenance intended to be carried out by the user should not be done by children without supervision.

Specific warnings for R32

The document only contains some of the safety rules regarding R32 refrigerant. For more comprehensive information, please read the safety data sheet available from the retailer.

- ⚠ In each chapter, specific warnings are included for the operations described within. These warnings should be read before starting any activities.
- ⚠ All precautions regarding the handling of refrigerant must be followed in accordance with current regulations.
- ⚠ The unit uses R32 refrigerant, with a Global Warming Potential (GWP) of 675. Do not release R32 gas into the atmosphere.
- ⚠ The R32 refrigerant gas is mildly flammable and odourless.
- ⚠ Do not place flammable objects (spray cans) within 1 meter of the air discharge.
- ⚠ Avoid proximity to continuously operating ignition sources (open flames, gas appliances, electric stoves, lit cigarettes, etc.).
- ⚠ In case of refrigerant gas leakage, ventilate the area thoroughly and move away. Promptly call the Authorised Service Centre or professionally qualified personnel and do not personally intervene on the appliance.

1.3 Basic safety rules

We would like to remind you that the use of products that use electricity and water involves observing certain basic safety precautions such as:

- ⊖ It is forbidden to touch the appliance with wet or damp body parts.
- ⊖ It is forbidden to carry out any operation before disconnecting the appliance from the power supply by setting the plant master switch to "OFF".

- ⊖ It is forbidden to modify the safety or adjustment devices without the authorisation and instructions of the appliance manufacturer.
- ⊖ It is forbidden to pull, unplug or twist the electrical cables coming out of the appliance, even if it is disconnected from the mains supply.

- ⊖ It is forbidden to introduce objects and substances through the openings provided for the intake and delivery of air.
- ⊖ It is forbidden to open the access doors to the internal parts of the appliance without first setting the plant master switch to "OFF".
- ⊖ It is forbidden to dispose of packaging material and leave it within reach of children as it can be a potential hazard.

1.4 Disposal



In such case, it complies with the requirements set by the directive for the chemical substance involved.

The symbol on the product or packaging indicates that the product should not be treated as normal household waste. Instead, it should be taken to an appropriate collection point for recycling of electrical, electronic, and battery equipment.

Proper disposal of this product avoids harm to humans and the environment and promotes the reuse of valuable raw materials.

For more detailed information about the recycling of this product, contact your local authority, your household waste disposal service, or the shop where you purchased the product.

Illegal disposal of the product by the user involves the application of the administrative sanctions provided for by the regulations in force.

This provision is only valid in the EU Member States.

⚠ Avoid disassembling the appliance yourself.

⚠ **Contact an Authorised Service Centre to disassemble the appliance.**



This symbol could be used in combination with a chemical symbol.

2. PRODUCT INTRODUCTION

2.1 Identification

The appliance can be identified by the rating plate:

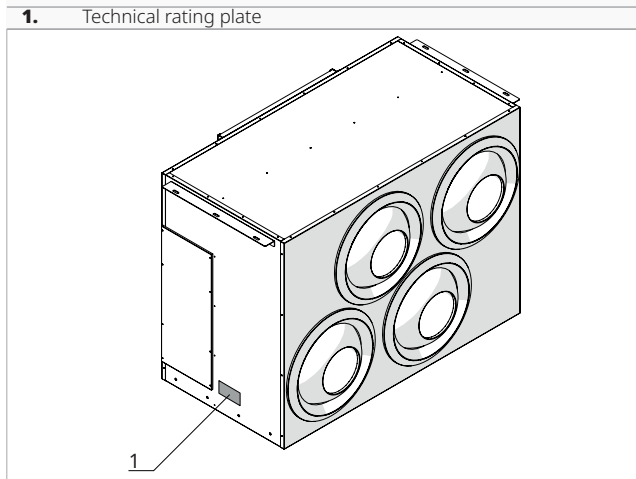

Technical rating plate

This shows the technical and performance specifications of the appliance.

⚠ Tampering with, removing or missing identification plates does not allow the product to be reliably identified by its serial number and therefore invalidates the warranty.

2.2 Destination of use

OKKI is a system designed for large environments, such as industrial halls and extensive spaces. A cutting-edge solution that ensures maximum comfort and cost-effectiveness. It is equipped, on the internal unit, with the SmartJet system: an innovative system with motorized and self-directing nozzles that independently and autonomously reg-

ulate the direction and temperature of the air to prevent stratification and ensure the maintenance of the desired temperature in the occupied area. This appliance is intended to be used by expert or trained users in shops, light industry, and farms, or for commercial use by laypersons.

2.3 Description of the appliance

Structure: internally coated and galvanized sheet metal.

Brushless fans: radial fans with backward-facing blades.

Heat exchanger: air-to-air type made of copper-aluminum material.

Motorized nozzles: allow for the direction of airflow based on the temperature of the supplied air.

Filters: G2 flat metallic filters with all galvanized components

Models: 2 sizes with different flow rates are available.

Versions: there are three different versions available, which can be requested based on individual preferences.

- SA: Smart Jet version with automatic nozzles
- SM: Version with manual nozzles
- SC: Ducted version

2.4 List of external components

- | | | | |
|----|---------------------------|----|----------------------|
| 1. | Nozzle / Motorized nozzle | 3. | Installation bracket |
| 2. | Electrical panel | | |

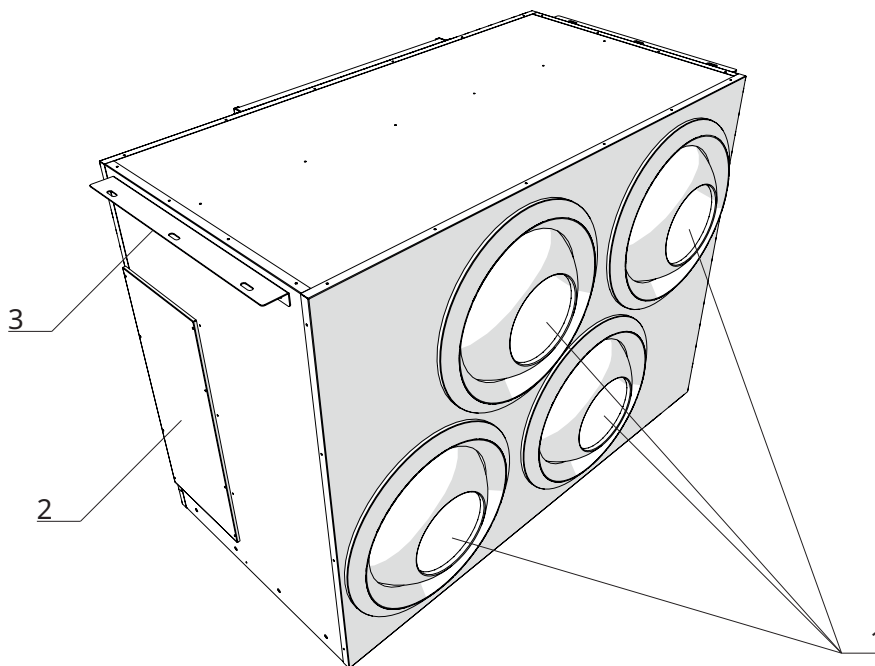

Size 30

- | | | | |
|----|-------------------------------|----|-------------------------------|
| 1. | External unit connection 7/8" | 4. | Extract air filter |
| 2. | External unit connection 1/2" | 5. | Electrical connection passage |
| 3. | Condensate drain | | |

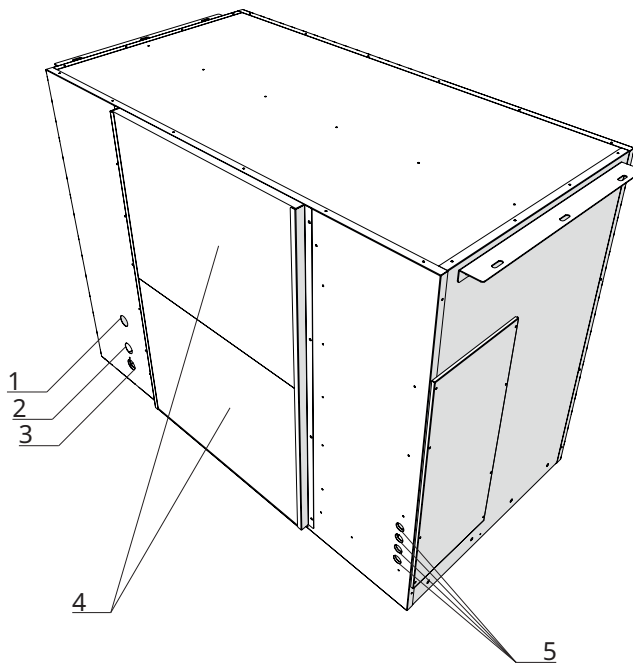

General

Size 15

- | | | | |
|----|-------------------------------|----|-------------------------------|
| 1. | External unit connection 3/8" | 4. | Extract air filter |
| 2. | External unit connection 5/8" | 5. | Electrical connection passage |
| 3. | Condensate drain | | |

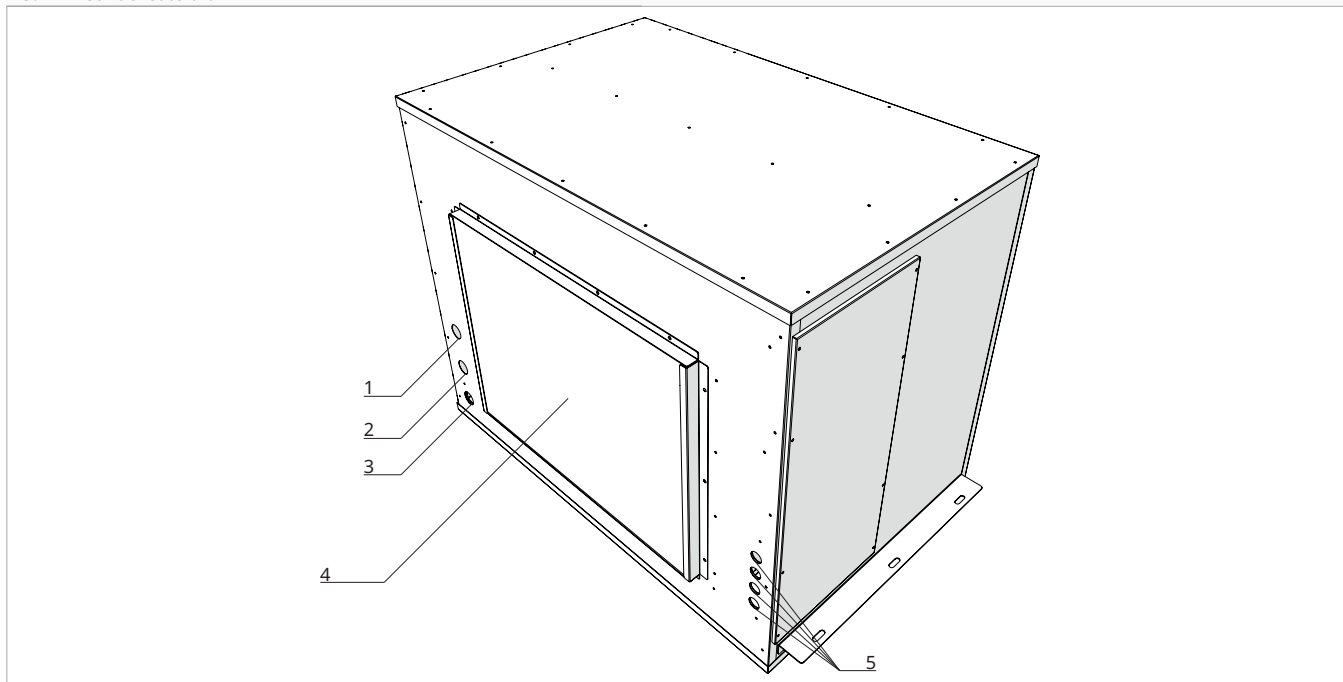

2.5 List of internal components

- | | | | |
|----|-----|----|----------------|
| 1. | Fan | 2. | Heat exchanger |
|----|-----|----|----------------|

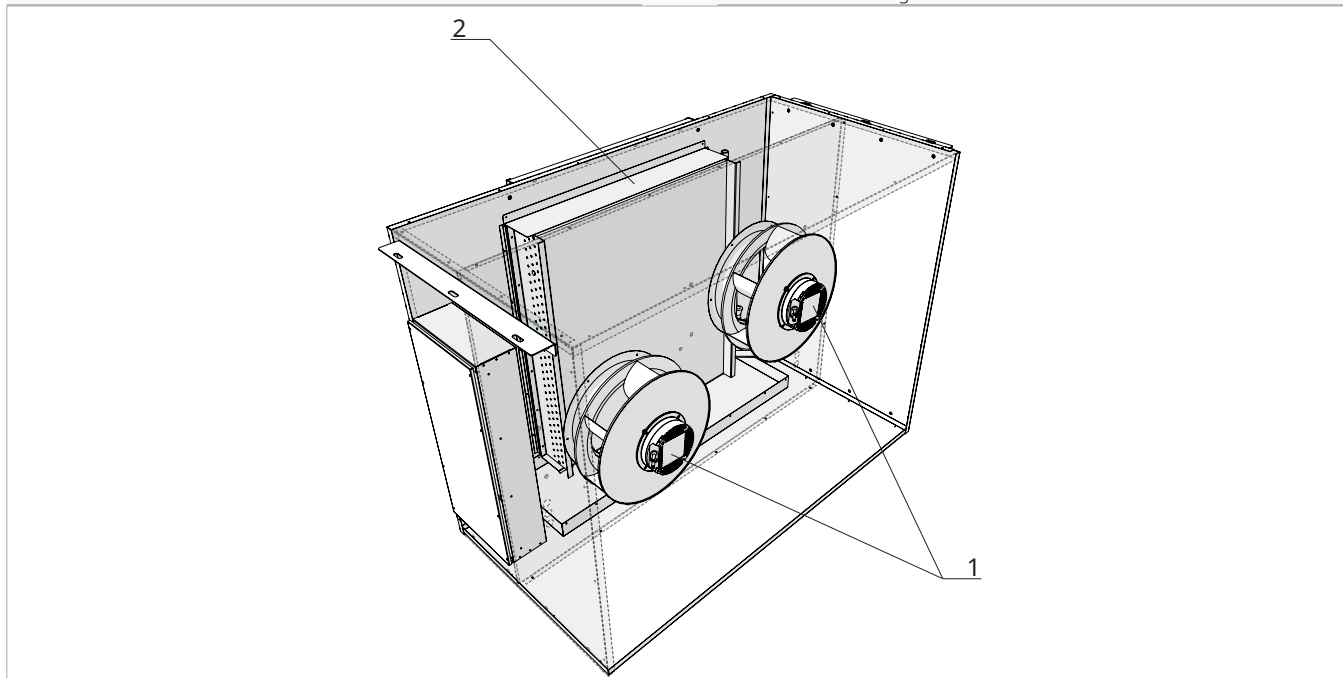

2.6 Configurations

Size 30

A SA: Smart Jet version with automatic nozzles
B SM: Version with manual nozzles

C SC: Ducted version

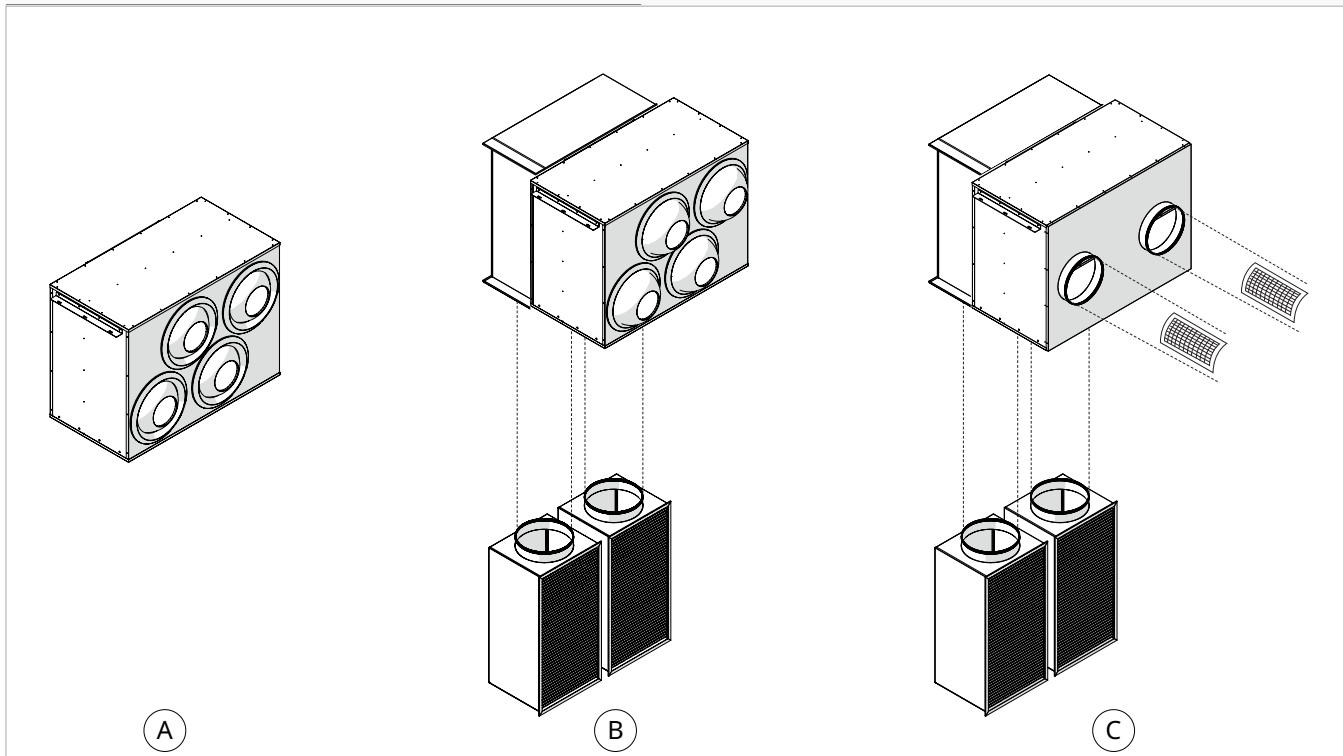

Size 15

A SA: Smart Jet version with automatic nozzles
B SM: Version with manual nozzles

C SC: Ducted version

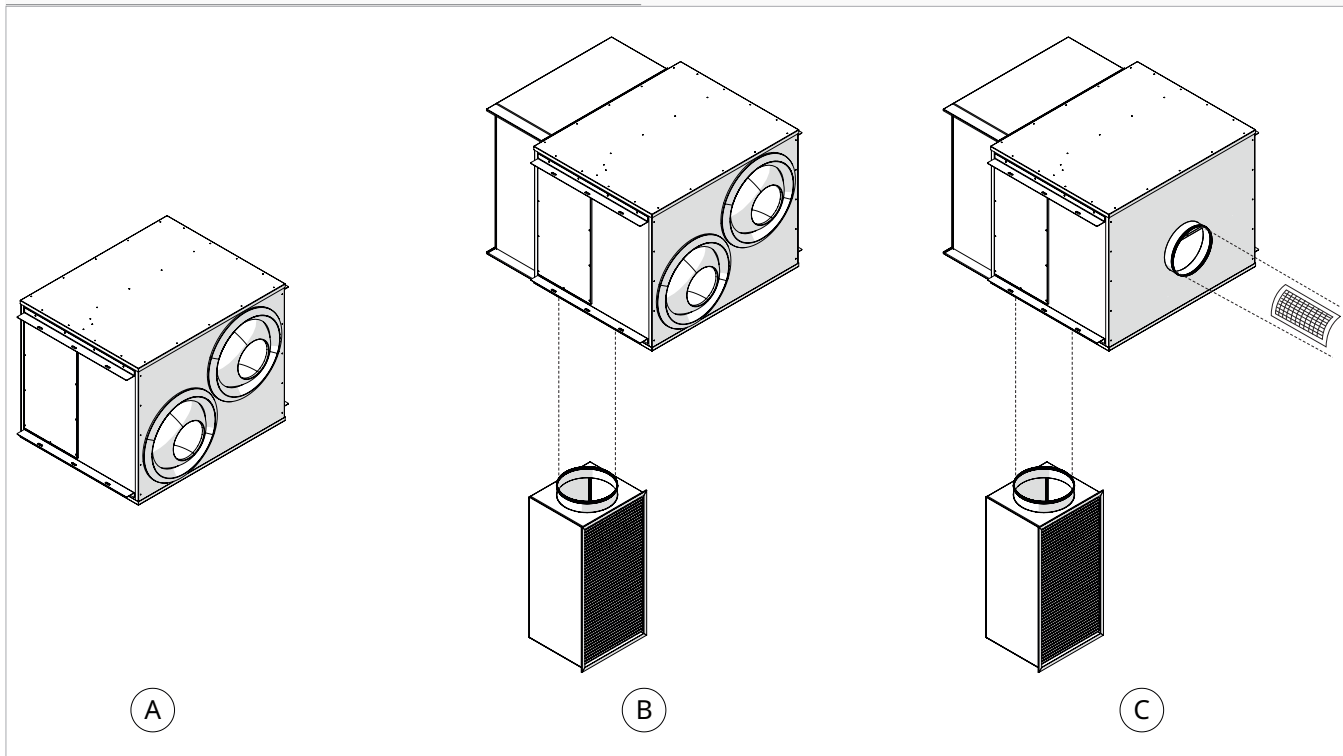



General

A SA: Smart Jet version with automatic nozzles
B SM: Version with manual nozzles

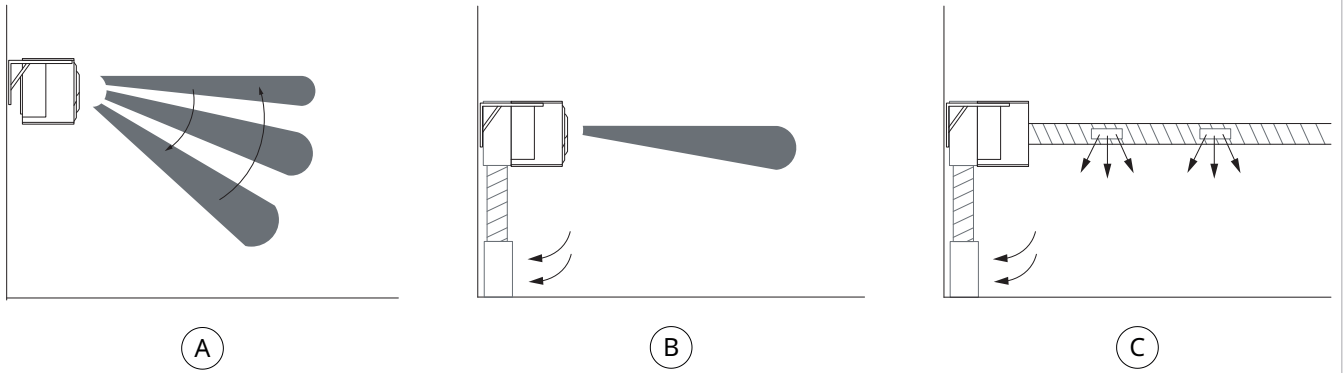
C SC: Ducted version

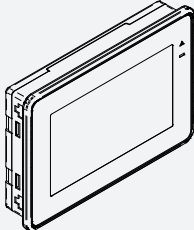
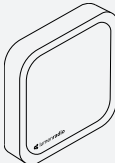
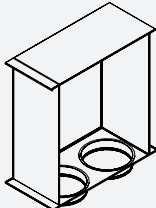
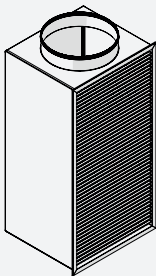

2.7 Compatible accessories

Description	Code
Commands	
	<p>Digital remote control with color touchscreen</p> <p>AHRX0012II</p>
	<p>Wi-Fi module to be ordered, paired with the remote control for radio communication between units. Prepare one Wi-Fi module for each unit</p> <p>AHRX0013II</p>
Room temperature sensor	
	<p>Remote ambient temperature sensor for insertion into blind button</p> <p>AHRA0039II</p>
Ducted air intake plenum kit	
	<p>Rear air intake module with bottom attachment for displacement module, 1 x DN 355 mm. Dimensions (WxHxD): 720x624x453 mm</p> <p>AHRX0051II</p>
	<p>Rear air intake module with bottom attachment for displacement module, 2 x DN 355 mm. Dimensions (WxHxD): 1080x1024x453 mm</p> <p>AHRX0052II</p>
Ground air intake module	
	<p>Ground air intake module for displacement, supplied complete with grille and filter, 1 x DN 355 mm. Dimensions (WxHxD): 535x1035x495 mm</p> <p>AHRX0061II</p>
Duct grille for air supply	
	<p>Channel air supply grille for ducted configuration. Internal dimensions of grille (WxH): 400x200 mm. Airflow capacity 500 m³/h, throw 7 m. Provide 5 grilles for size 15 T and 10 grilles for size 30 T</p> <p>AHRX007II</p>

3. INSTALLATION

3.1 Preliminary warnings

- ⚠ **For detailed information on the products, refer to chapter "Technical information" p. 55.**
- ⚠ The installation must be carried out by the installer. There is a risk of water leakage, electric shock or fire if the installation is not performed correctly.
- ⚠ During installation, it is necessary to observe the precautions mentioned in this manual, and on the labels affixed to the inside of the appliances, as well as to take every precaution suggested by common sense and the safety regulations in force at the place of installation.
- ⚠ Using only the supplied installation-specific components is recommended. Use of alternative components could lead to water leakage, electric shock or fire.

- ⚠ Failure to apply the indicated rules may cause malfunctions of the appliance and relieves the Manufacturer from any warranty and from any damage caused to persons, animals or property.

Preliminary warnings for R32

- ⚠ Before working on systems containing flammable refrigerants, it is necessary to perform safety checks to ensure that the risk of combustion is minimised.
- ⚠ The appliance must be protected from accidental impacts to prevent mechanical damage.
- ⚠ Do not pierce or burn.

3.2 Reception

Preliminary warnings

- ⚠ Upon receipt of the package check that it is not damaged, otherwise accept the goods with reservation, producing photographic evidence of any damage.
- ⚠ In the event of damage, notify the shipper by registered mail with return receipt within 3 days of receipt. Presenting photographic documentation, similar information should also be sent by email to the Manufacturer.
- ⚠ No reports of damage will be taken into account later than 3 days after delivery.

- ⚠ The packaging should be transported in a vertical position without tilting. If it is tilted, please notify the carrier immediately.

Package description

The packaging is made of suitable material and carried out by experienced personnel.
The units are all checked and tested and are delivered complete and in perfect condition.
The appliance is shipped in standard packaging consisting of a cardboard box and a set of polystyrene foam protectors, placed on a wooden pallet and secured with straps.

3.3 Dimensions and weights with packaging

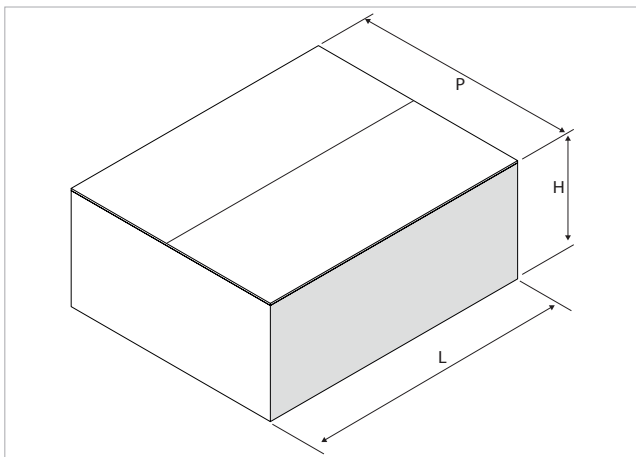

Models	u.m.	15	30
Packaging dimensions (1)			
Width	mm	1080	1430
Depth	mm	880	1100
Height	mm	1030	1100
Weight	kg	92,0	135,0
1. Excluding pallet			

3.4 Handling with packaging

Preliminary warnings

- ⚠ The product should only be handled by qualified personnel, adequately equipped, and using tools suitable for the weight and dimensions of the product.
- ⚠ Before each handling operation, check the lifting capacity of the machinery used in accordance with the indications on the packaging.

Handling

With pallet:

- ▶ use a forklift

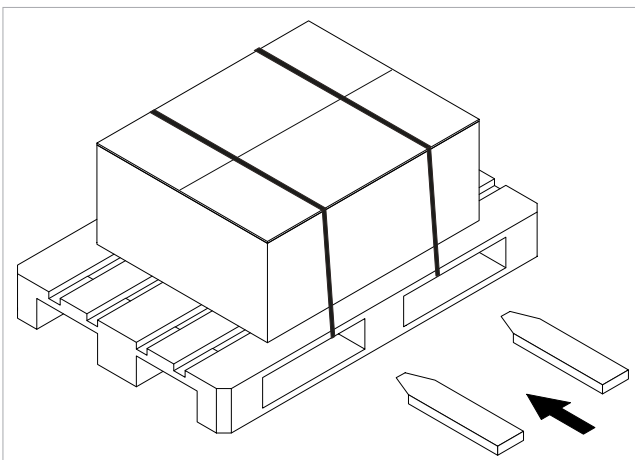

Without pallet:

- ▶ use the handles provided on the packaging

- ⚠ The packaging must be transported in a vertical position without being tilted.
- ⚠ When the load is lifted from the ground, stay clear of the immediate and surrounding area.
- ⚠ Check the information on the packaging for the amount of stackable packages.
- ⚠ In manual operations, the maximum weight per person required by current legislation must always be observed.

- ⚠ The unit can only be moved manually for short trips in exceptional cases. In this case it is necessary to carefully check that the weight of the unit does not exceed what is stipulated by the regulations with respect to the number of persons employed.

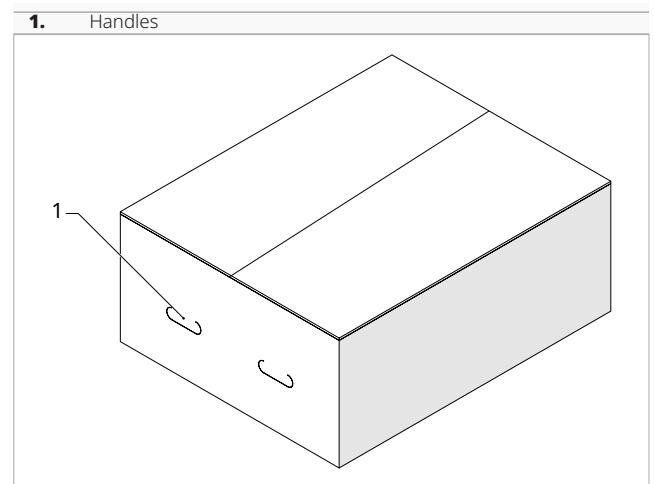

3.5 Storage

Preliminary warnings

- ⚠ Stored in accordance with the applicable national regulations.
- ⚠ Store in a closed environment protected from the weather, off the ground by means of sleepers or pallets

with temperatures not below 0 °C, up to a maximum of 40 °C.

- ⚠ Do not overturn the packaging.
- ⚠ Place the appliance only in a vertical position.

3.6 Unpacking

Preliminary warnings

- ⚠ Check that the individual components are present.
- ⚠ Check that no components were damaged during transport.
- ⚠ Dispose of the packaging components following the applicable waste disposal regulations. Check for disposal arrangements with your local authority.
- ⚠ Handle with care.
- ⚠ The appliance must always be moved in a vertical position.

- ⊖ The packing material (cardboard, staples, plastic bags, etc.) must not be dispersed or abandoned in the surrounding environment and must be kept out of reach of children due to risk of hazard.

Installation

Removing the packaging

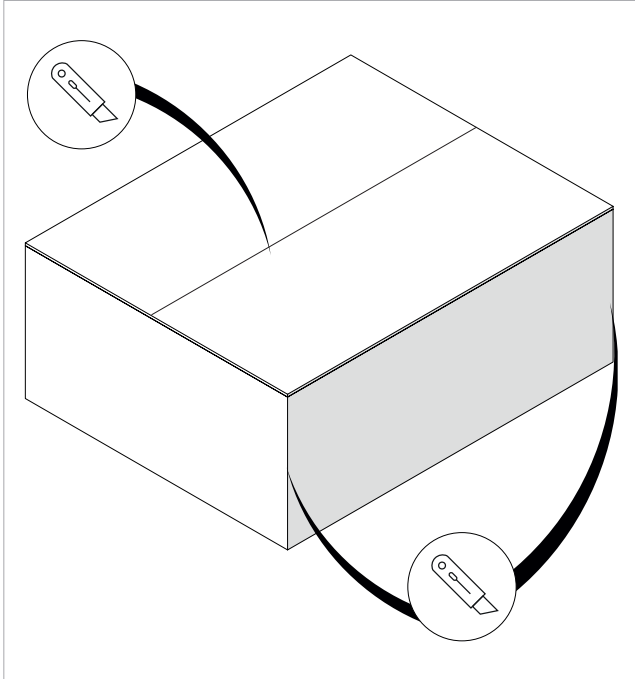

To remove the packaging:

- ▶ use a cutter
- ▶ open the cardboard packaging
- ⓘ To aid removal of the product, also cut the vertical edges.
- ▶ remove the accompanying components
- ▶ remove the polystyrene elements
- ▶ remove the appliance from the box

Accompanying material

They are included with the appliance, inside the packaging:

- Indoor unit installer manual
- User manual
- Tube for gas connection (only for size 30)
- ⚠ Check the presence of the individual components.

3.7 Handling without packaging

Preliminary warnings

- ⚠ The appliance must be handled only by qualified personnel, adequately equipped and with equipment suitable for the weight and dimensions of the appliance.
- ⚠ The unit must be handled using non-slip gloves.
- ⚠ Before each handling operation, check the lifting capacity of the machinery used in accordance with the indications on the packaging.
- ⚠ When the load is lifted from the ground, stay clear of the immediate and surrounding area.
- ⚠ Check the information on the packaging for the amount of stackable packages.

- ⚠ In manual operations, the maximum weight per person required by current legislation must always be observed.

Movement methods

- ▶ use a fork lift, scaffolding or other suitable lifting system
- ⚠ The unit can only be moved manually for short trips in exceptional cases. In this case it is necessary to carefully check that the weight of the unit does not exceed what is stipulated by the regulations with respect to the number of persons employed.

3.8 Installation site

The location of the appliance must be determined by the plant engineer or a competent person and must take into account both purely technical requirements and any national/local legislation in force.

The device is intended to be installed indoors in a vertical position, fixed to the wall.

- ⚠ The installation position must be chosen close to a wall connected to the outside.

Preliminary warnings

- ⚠ Avoid installing the unit in the vicinity of:
 - obstacles or barriers that cause recirculation of the exhaust air
 - narrow places where the sound level of the appliance can be enhanced by reverberations or resonances

- environments with the presence of flammable or explosive gases
- very damp environments (laundries, greenhouses, bathrooms with high humidity, etc.) to prevent the formation of condensation on the external panels of the unit
- environments with the presence of flammable or explosive gases or flammable fluids
- solar radiation and proximity to heat sources
- ⚠ Avoid placing the unit within 1 metre of radio and video equipment.
- ⚠ Do not install above heat sources.
- ⚠ Ensure that:
 - the installation site of the unit must be chosen with the utmost care to guarantee adequate protection from shocks and consequent damage

- the supporting surface is capable of supporting the weight of the appliance
- the supporting surface does not affect load-bearing building elements, piping, or power lines
- the functionality of load-bearing elements is not compromised
- there are no obstacles to the free circulation of air through the holes (plants, leaves...)
- the appliance must be installed in a position where it can be easily serviced
- the safety distances between the units and other appliances or structures are scrupulously respected so that the air entering and leaving the fans is free to circulate
- ⚠ If improperly installed or placed on an unsuitable surface, the unit, if detached from its base, may cause damage to persons or property.
- ⚠ The appliance must not be in a position where the air flow is aimed directly at a person.
- ⚠ Provide the following:
 - a drain nearby for the outflow of condensation
 - a compliant power supply nearby

Preliminary warnings for R32

- ⚠ The appliance must be installed in well-ventilated environments that have a minimum floor area as indicated in the table "Minimum Floor Area" based on the total refrigerant charge of the circuit.
- ⚠ **The refrigerant charge refers to the total amount of refrigerant in the circuit, which includes the factory charge and any additional charge.**
- ⚠ Please refer to the technical rating plate on the associated outdoor unit for the quantity of refrigerant loaded into the unit.
- ⚠ If the appliance is placed in a poorly ventilated area, precautions must be taken to prevent the accumulation of leaked refrigerant, thus avoiding the risk of fire or explosion.
- ⚠ The appliance should be placed in a room where there are no continuously operating open flames (such as a

gas appliance in operation) or ignition sources (such as an operating electric heater).

- ⚠ Any ventilation openings must be kept clear of obstacles.
- ⚠ Perform the following checks:
 - Perform safety checks to ensure that the risk of combustion is minimised
 - avoid working in confined spaces
 - delimit the area around the workspace
 - ensure safe working conditions around the area by checking for flammable materials

Minimum floor area

m (kg)	A _{min} (m ²)
1,8	Without limitations
2,0	2,55
2,1	2,81
2,2	3,09
2,3	3,38
2,4	3,68
2,5	3,99
2,6	4,31
2,8	5,00
3,0	5,74
3,4	7,38
3,8	9,22
4,2	11,26
4,6	13,50
5,0	15,96
5,4	18,61
5,8	21,47

2. **M** Refrigerant charge
3. **A_{min}** Minimum floor area

3.9 Minimum installation distances

The clearance zones for the installation and maintenance of the appliance are shown in the figure below. Established spaces are necessary to avoid barriers to airflow and allow for normal cleaning and maintenance.

- ⚠ Make sure that there is sufficient space to allow the panels to be removed for routine and supplementary maintenance operations.
- ⚠ Ensure a spacious and open area in front of the unit to guarantee proper airflow.

Installation

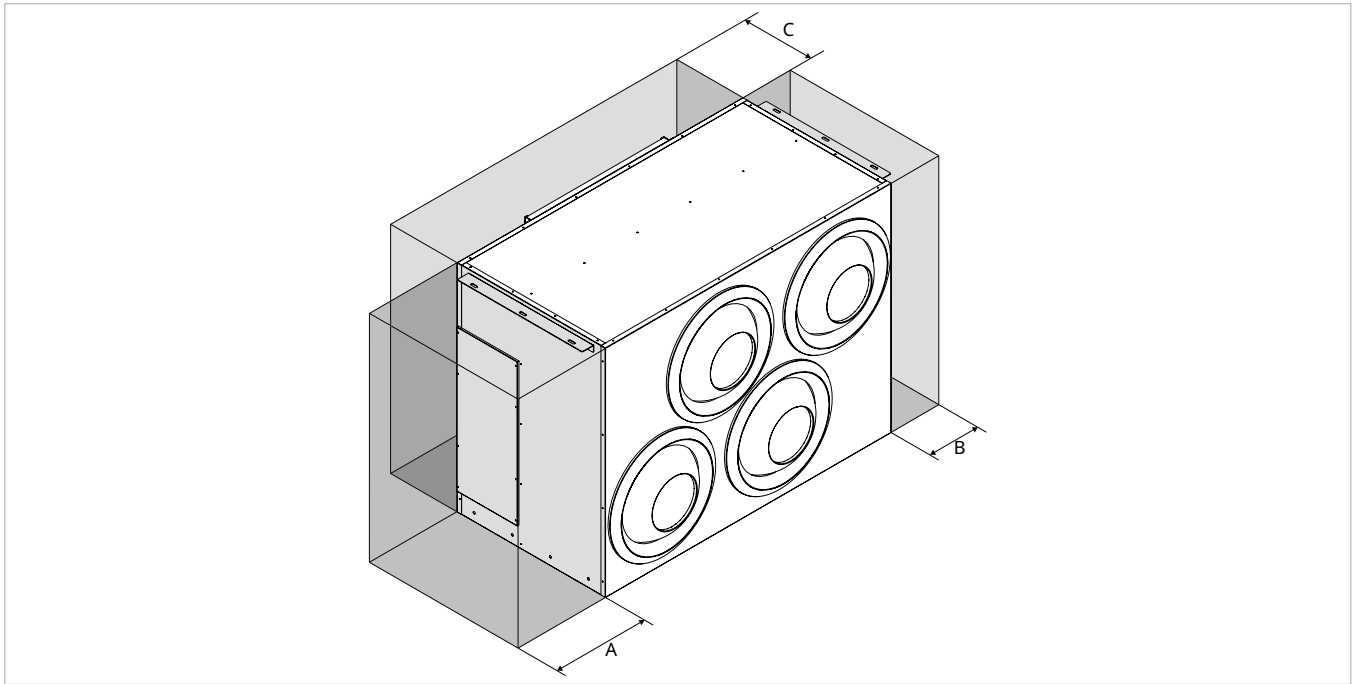

Models	u.m.	15	30
Minimum distances			
A	mm	500	500
B	mm	200	200
C	mm	300	300

Installation height limits

- A** Minimum installation height
- B** Maximum installation height

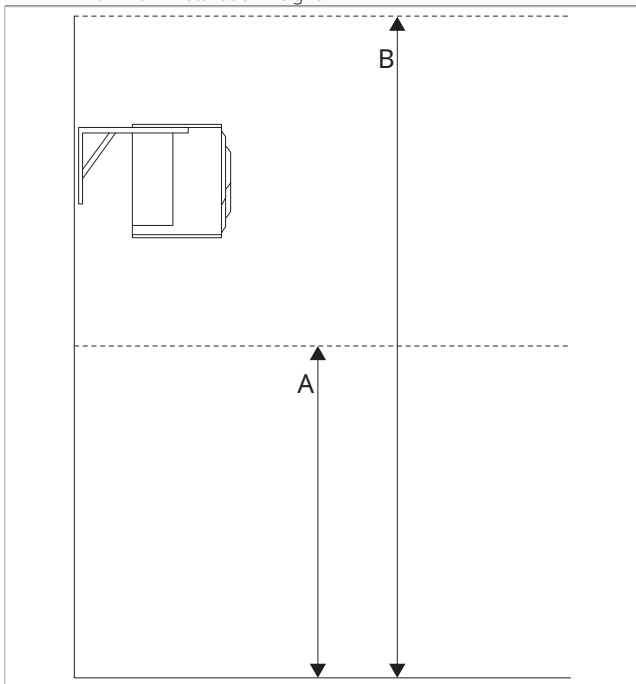

Models	u.m.	15	30
Installation limits			
A	mm	3000	3000
B	mm	6000	6000

⚠ The established heights are necessary to ensure the proper functioning of the unit.

3.10 Positioning

Preliminary warnings

⚠ Check that:

- the surface supports the weight of the appliance
- the surface does not affect piping or power lines
- the functionality of load-bearing elements is not compromised

Positioning the unit

The unit can be installed in two different ways:

- Vertical ceiling installation
- Vertical wall installation

Installation brackets

The unit is supplied with installation brackets positioned laterally.

It is possible to modify the position of the brackets.

1. Upper installation bracket

2. Lower installation bracket

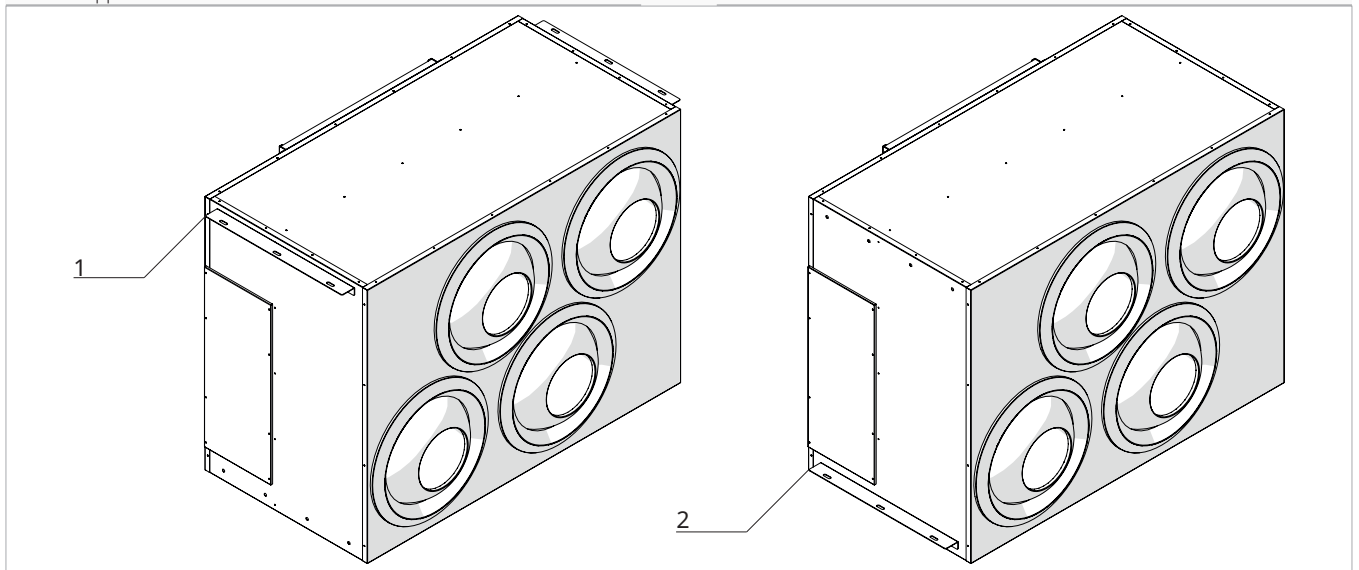

To modify the position of the brackets:

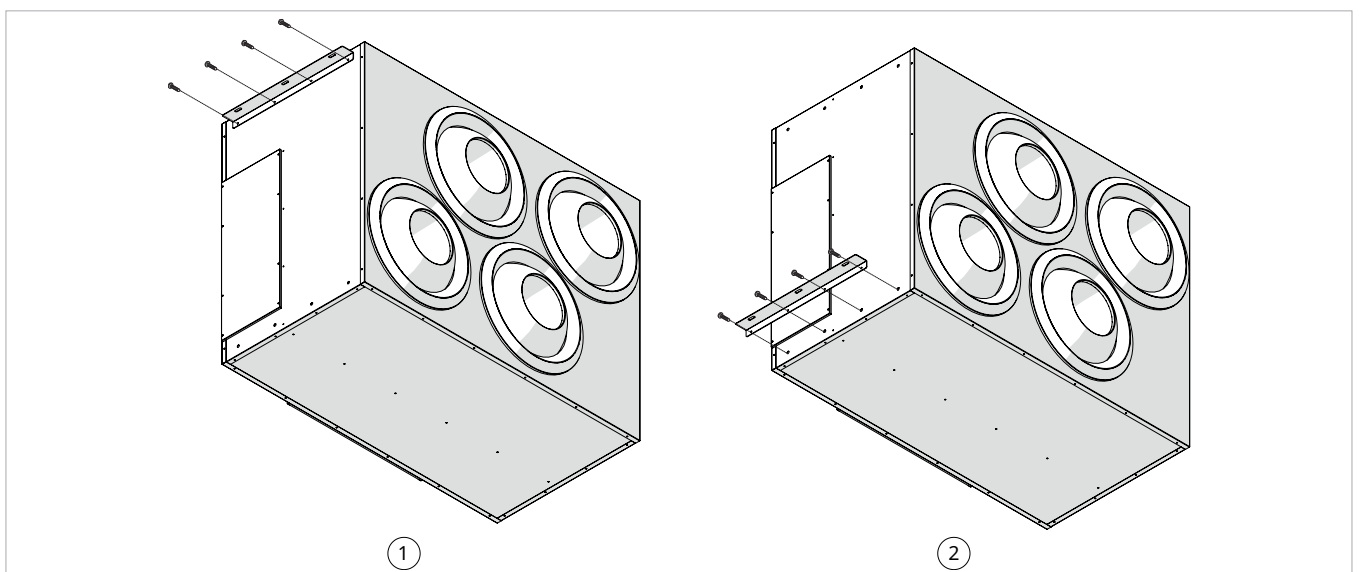

- ▶ remove the screws from the installation bracket
- ▶ install the bracket on the bottom of the unit using the previously removed screws

Installation

Wall installation

⚠ Check the correct orientation of the unit.

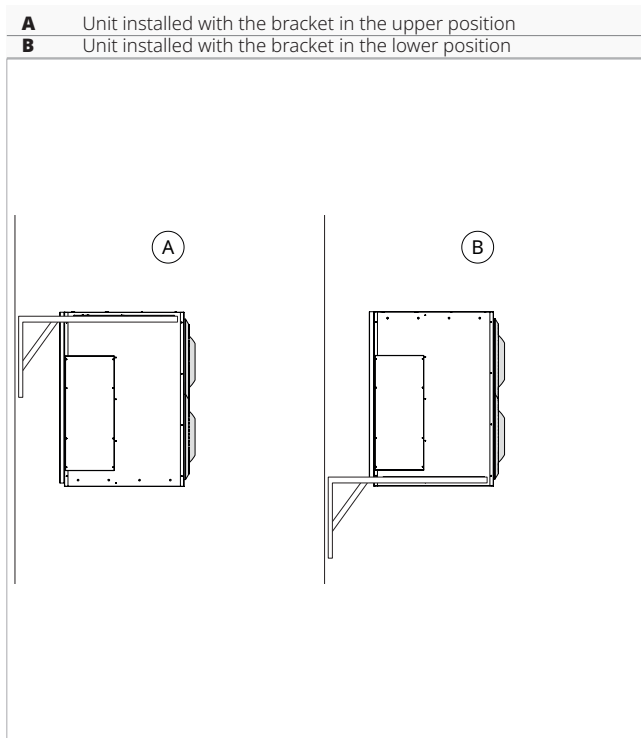

- ▶ mark the position of the fixing holes
- ▶ use fixing systems appropriate for the type of supporting surface and the weight of the unit
- ▶ secure the unit to the fixing system

Check that:

- it is levelled
- the minimum distances and installation height limits are respected

Ceiling installation

⚠ Check the correct orientation of the unit.

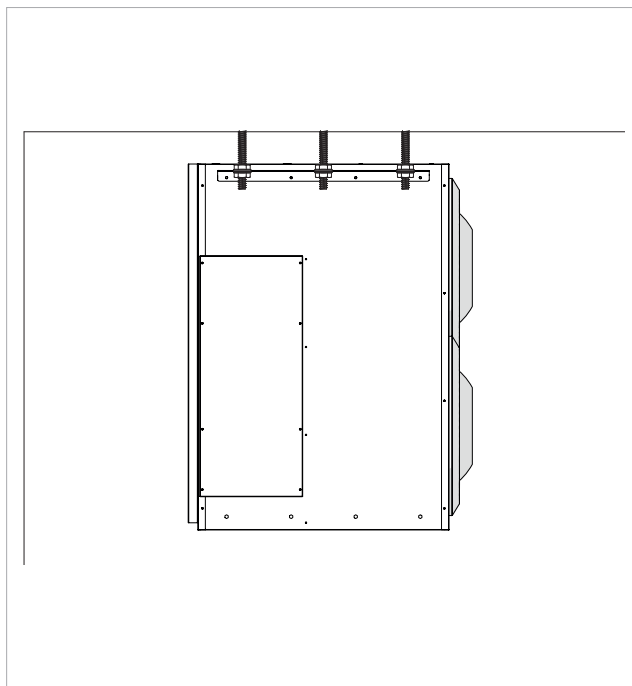

- ▶ mark the position of the fixing holes
- ▶ use fixing systems appropriate for the type of supporting surface and the weight of the unit
- ▶ secure the unit to the fixing system

Check that:

- it is levelled
- the minimum distances and installation height limits are respected

3.11 Refrigeration connections

Preliminary warnings

- ⚠ **The installer must comply with Regulation 303/2008/EC, which, in accordance with Directive 842/2006/EC, defines the requirements for companies and personnel concerning the fixed refrigeration, air conditioning, and heat pump equipment containing certain fluorinated greenhouse gases.**
- ⚠ **For dimensional information, refer to the chapter "Technical information" p. 55.**
- ⚠ Use equipment suitable for the system refrigerant.
- ⚠ Identify the piping route to minimize tubing length and bends, maximizing system efficiency.
- ⚠ The refrigerant lines should be as straight as possible, and any necessary bends must have a radius greater than 40 mm.
- ⚠ Use exclusively copper pipes specifically designed for refrigeration.
- ⚠ The pipes must be supplied clean and sealed at the ends. It is possible to use pre-insulated copper pipes for refrigeration.

- ⚠ The pipes must not contain residues of debris, dirt, or water that could damage the components of the unit and compromise the proper functioning of the appliance.
- ⚠ Handle the refrigerant with care. Leaking refrigerant can cause frostbite.
- ⚠ For safety and installation requirements relating to the outdoor unit and overall system installation, please refer to the relevant outdoor unit documentation.
- ⊖ It's forbidden to use pipes with a diameter different from that indicated in the technical data table.
- ⊖ Using refrigerant lines that have been previously used is prohibited as the seal at the flare connection cannot be guaranteed.
- ⊖ Connecting using regular hydraulic pipes is prohibited.
- ⊖ Welding is prohibited in the presence of refrigerant within the refrigeration circuit. If necessary, the refrigerant must be recovered, and the circuit cleaned using oxygen-free nitrogen.

Specific warnings for R32

- ⚠ The length of the connecting pipes must be minimized.
- ⚠ Connecting pipes must be shielded from physical damage and should not be installed in an unventilated space smaller than the area specified in the Minimum Floor Area table.
- ⚠ The connecting pipes must be installed in a position unlikely to be exposed to corrosive substances, unless they are made from materials inherently corrosion-resistant or adequately protected against corrosion.
- ⚠ Compliance with national regulations for the gas used is mandatory.
- ⚠ Refrigerant connections must be accessible for maintenance purposes.
- ⚠ Work must be undertaken following a controlled procedure to minimize the risk of presence of flammable gases or vapors while the work is being carried out.
- ⊖ Performing hot work (welding, brazing, etc.) is prohibited.
- ⚠ To make refrigerant connections, the following precautions must be taken:

Area checks

- Perform safety checks to ensure that the risk of combustion is minimised
- avoid working in confined spaces
- delimit the area around the workspace
- ensure safe working conditions around the area by checking for flammable materials

Refrigerant fluid presence checks

- the area must be checked with a specific refrigerant fluid detector before and during work, so the technician is aware of potentially flammable atmospheres
- ensure that the leak detection apparatus is suitable for use with flammable refrigerants, meaning it does not produce sparks, is properly sealed, or inherently safe
- ⊖ Using combustion-based refrigerant fluid detectors, such as a halide torch or any other system using an open flame, is prohibited.

Combustion source checks

- people performing work on a refrigeration system involving exposed piping containing or having contained a flammable refrigerant fluid must refrain from using any combustion source that could lead to the risk of fire or explosion
- all potential combustion sources, including smoking a cigarette, must be kept sufficiently far from the work area during operations in which flammable refrigerant fluid could be released into the surrounding space
- check the surrounding area of the equipment to ensure there are no fire hazards or combustion risks
- place signs stating "No Smoking"

Ventilation area checks

- ensure the area is adequately ventilated
- during work, there must be a continuous level of ventilation

- ventilation should safely disperse any released refrigerant fluid and preferably expel it outside into the atmosphere

Leak detection

- ⊖ Using combustion-based refrigerant fluid detectors, such as a halide torch or any other system using an open flame, is prohibited.
- ⚠ For leak detection, follow the following instructions:
 - use electronic detectors to search for flammable refrigerant fluids
 - before usage, ensure the detectors are properly calibrated
 - calibration operations must be carried out in an area free from refrigerant fluid
 - ensure the detector is not a potential ignition source and is suitable for the refrigerant fluid used
 - if a leak is suspected, all open flames must be eliminated
 - in the event of a leak requiring brazing, it is mandatory to recover all refrigerant fluid from the system or isolate it (using shut-off valves) in a part of the system away from the leak
- ⚠ The use of silicone sealant can compromise the effectiveness of certain types of leak detection instruments.

Recharge procedure

- ⚠ For the recharge procedure, ensure that:
 - there is no contamination between different refrigerant fluids
 - the charging equipment's flexible hoses are as short as possible to minimise the amount of refrigerant fluid
 - the cylinders are kept in an upright position
 - ground the refrigeration system before proceeding with the charge
- ⚠ Before proceeding with the charge, ensure that the leak check has been performed.
- ⚠ Check for refrigerant leaks before leaving the site.
- ⚠ Label the system when the charge is complete.
- ⊖ Overloading the refrigeration circuit is prohibited.
- ⊖ It's prohibited to introduce a refrigerant fluid into the system other than the one indicated or to mix different refrigerant fluids.

Installation

Connection diagram

1. Liquid line
2. Gas line

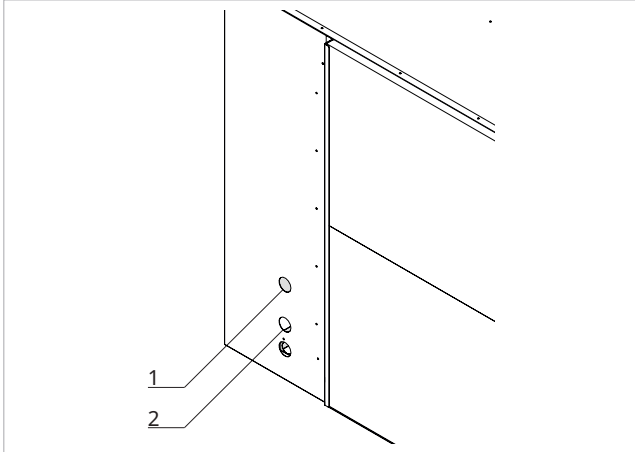

Piping connection

The refrigerant fittings, equipped with shut-off valves, are designed for flare or solder connections.

Preliminary warnings

- ⚠ Mount a cable duct (preferably with internal separators) of suitable dimensions on the wall to later pass the pipes and electrical cables through.
- ⚠ Cut the pipe sections with an excess of approximately 3-4 cm in length.
- ⚠ Immediately after cutting and deburring, seal the tube ends with insulating tape.
- ⚠ Remove any burrs using the appropriate tool.
- ⚠ Make the cut solely using a tube cutter wheel, tightening at small intervals to avoid crushing the pipe.
- ⚠ **Never use a regular saw to cut the pipes; debris could enter the pipe and later circulate within the system, causing severe damage to the components.**
- ⚠ Avoid the introduction of non-condensable gases (such as air) into the circuit; otherwise, during operation, high pressures might occur, risking ruptures.

Flare connection

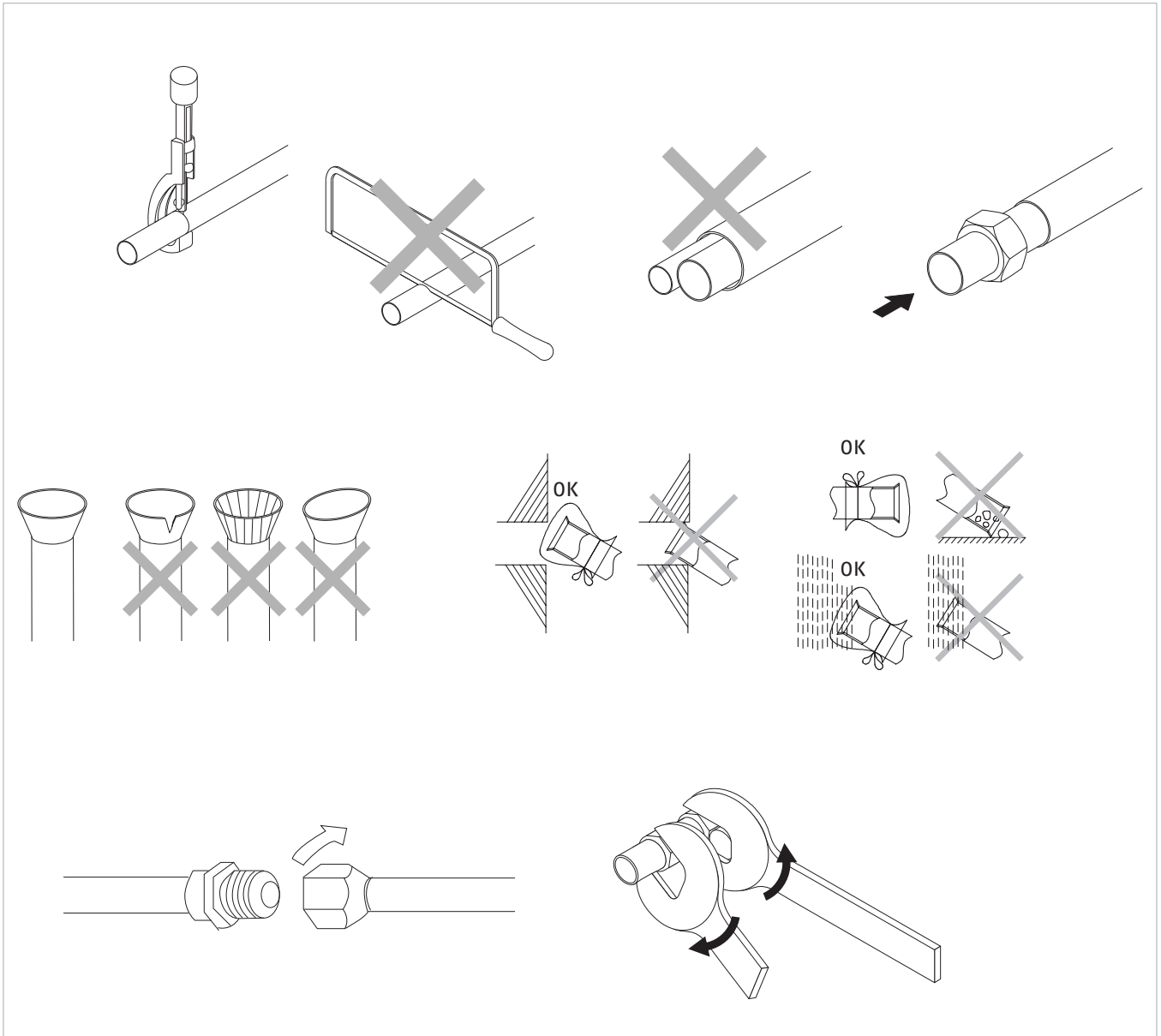

Before connecting:

- ▶ insert the fastening nut into the tube
- ▶ perform deburring on the tube ends using the appropriate tool
- ▶ lubricate the thread of the fitting with refrigerant oil
- ⚠ Do not use any other type of lubricant.
- ⚠ The deburring must not have any breaks, cracks, or splintering.
- ⚠ Avoid using refrigerant oil on the outer part of the flare.

To connect:

- ▶ position the refrigerant lines
- ▶ hand-tighten the tube nut onto the fitting thread
- ▶ use a wrench to hold the threaded part of the fitting steady
- ▶ use a torque wrench on the nut to securely tighten it
- ⚠ Keep the leak detector device on near the unit during the connection process to detect any refrigerant leaks promptly.

⚠ For subsequent operations, refer to the manual of the paired outdoor unit.

Pipe Ø		Tightening torque
mm	inches	Nm
6,35	1/4	18
9,52	3/8	42
12,70	1/2	55
15,88	5/8	60

Installation

Solder connection

- | | |
|----|--------------------------|
| 1. | Weldable stub pipe |
| 2. | External connection pipe |
| 3. | Adhesive tape |

- | | |
|----|-------------------------|
| 4. | Tap |
| 5. | Pressure reducing valve |
| 6. | Nitrogen tank |

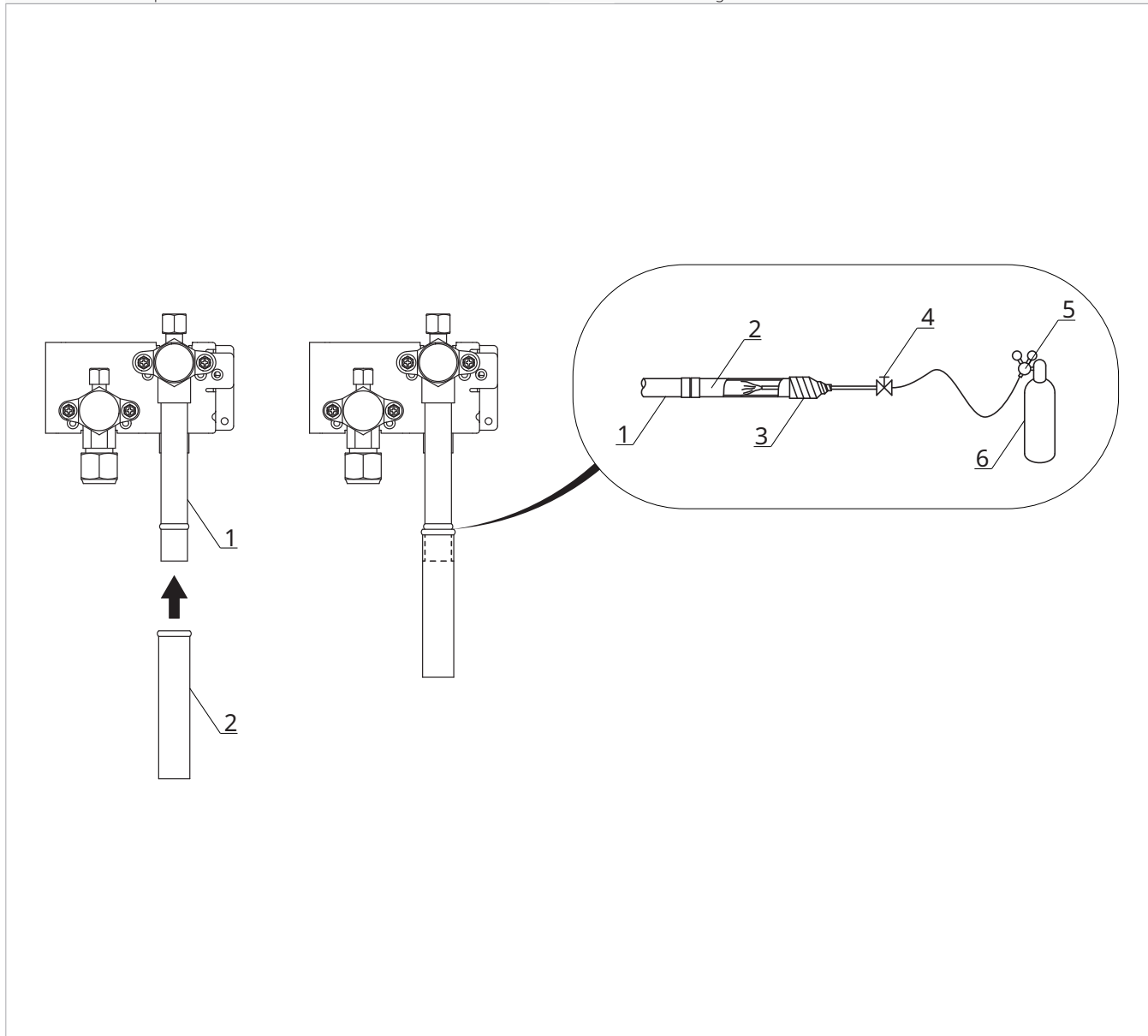

- ⚠ Make sure to replace the air inside the tube with nitrogen to prevent the formation of an oxide layer during the brazing process.
- ⚠ Make sure to use a damp cloth or other means to cool the valve during brazing.

To connect:

- ▶ bring the pipes closer together
- ▶ Insert the external connecting pipe into the designated stub

- ▶ perform the welding
- ⚠ Make sure the tube is securely fastened to the ring and that the entire system is properly aligned.
- ⚠ Make sure to use nitrogen. The use of oxygen, CO₂, and CFCs is not allowed.
- ⚠ Use a pressure reducing valve on the nitrogen tank.
- ⚠ Do not use agents intended to prevent the formation of oxide films. They will negatively affect the refrigerant oil and may cause equipment failure.

3.12 Condensate drain connection

This appliance comes with a tray to collect the condensation produced during operation. The condensation must be directed to a suitable discharge point.

Preliminary warnings

- ⚠ If the drainage line runs into a container (tank or other) it must be ensured that the container itself is hermet-

ically sealed and most importantly it must be ensured that the drainage pipe is not immersed in water.

- ⚠ The hole for the condensate pipe must always have an downwards slope.
- ⚠ The precise position where the tube inlet should be placed concerning the machine is specified on the drilling template.
- ⚠ Pay attention in this case to ensure that the expelled water does not cause any damage or inconvenience to objects or people. During the winter period, this water could lead to ice formations outside.
- ⚠ When connecting the condensate drain, take care not to crush the rubber pipe.
- ⚠ If necessary, you can empty the condensate collection tray through a safety drain provided on the unit's base.
- ⚠ If an external drainage pipe in "cooling-only" mode is not utilised, it is advisable to plug the condensate drain.

Attachment position

The size and position of the condensate drain attachments are shown below.

1. Condensate drain connection ø30

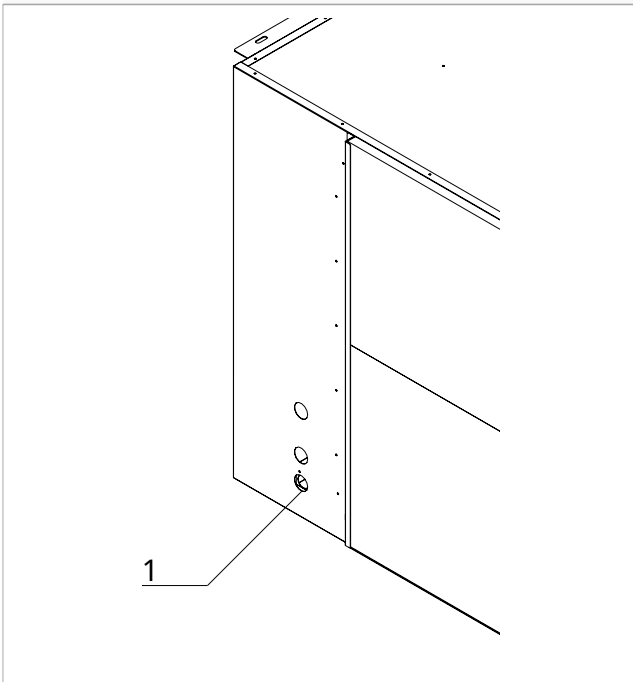

Connections

1. Unit

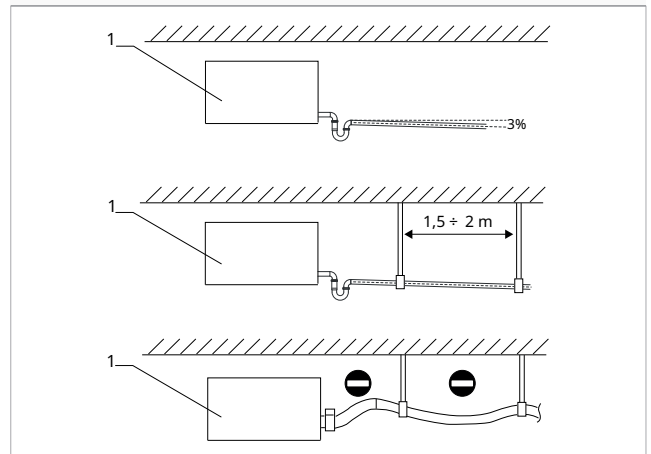

- ▶ Connect the drainage pipes to the fitting provided on the unit
- ▶ insert a siphon for each pipe near the unit.
- ⚠ If the drainage pipes are connected into a single pipe, install the siphons before the connection point.
- ▶ direct the drainage pipes toward a suitable discharge location
- ▶ maintain a minimum slope of 3% towards the drain location
- ▶ insulate junction points
- ⚠ **It is mandatory to install an adequate siphon on the condensate drainage pipe to prevent the negative pressure generated by the fans from obstructing the proper flow of condensate, which could lead to spillage inside the premises.**
- ⚠ The drainage system must include a suitable siphon to prevent unwanted air from entering the vacuum system. The siphon also prevents the entry of odours or insects.
- ⚠ The siphon must be fitted with a plug at the bottom or must in any case permit quick dismantling for cleaning.
- ⚠ Use plastic drainage pipes.
- ⚠ Avoid metal pipes.
- ⚠ Make sure all joints are sealed to prevent leakage of water.
- ⚠ Condensate drain pipes must be insulated for both indoor and outdoor sections to avoid condensation on the surface and/or frosting problems. The insulation must be inserted all the way to the condensate drain pipe connection on the unit.

Installation

3.13 Aeraulic connections

Below are the accessories available for ducting the unit.

1. Duct grille for air supply
2. Ducted configuration
3. Ducted air intake plenum kit
4. Ground air intake module

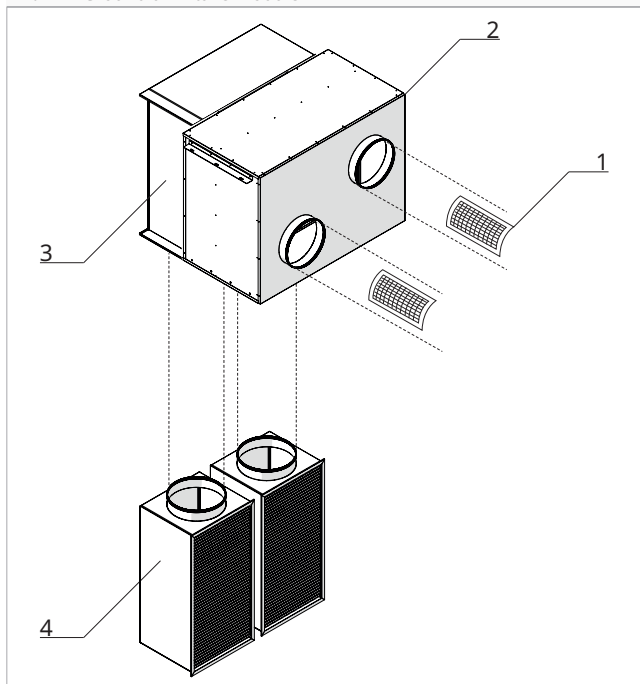

⚠ For the assembly of accessories, refer to the respective instruction sheet.

Preliminary warnings

- ⚠ The sizing of ducting and supply and extract grilles must be carried out by a professionally qualified person.
- ⚠ To prevent the transmission of any vibrations of the machine into the room, an anti-vibration joint should be placed between the fan outlets and the ducts.
- ⚠ The connecting pipes must be of a suitable diameter and supported so that their weight does not put strain on the appliance.

Connections

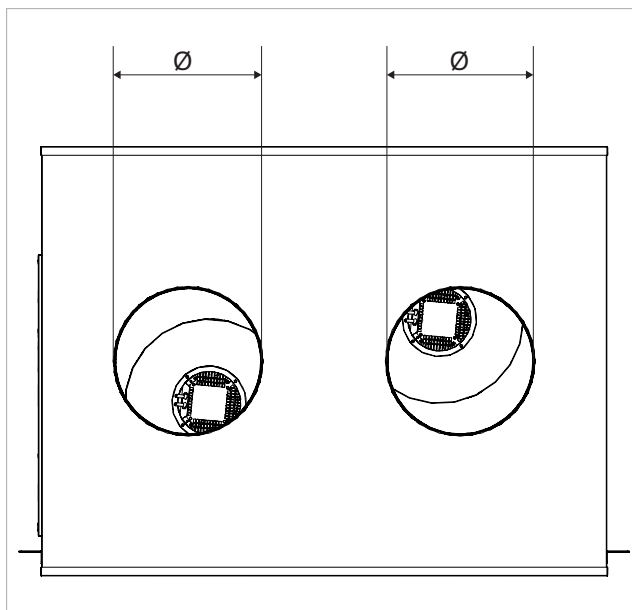

Models	u.m.	15	30
Connections			
Air connections (Ø)	mm	355	355
Connections number		1	2

Circular connections

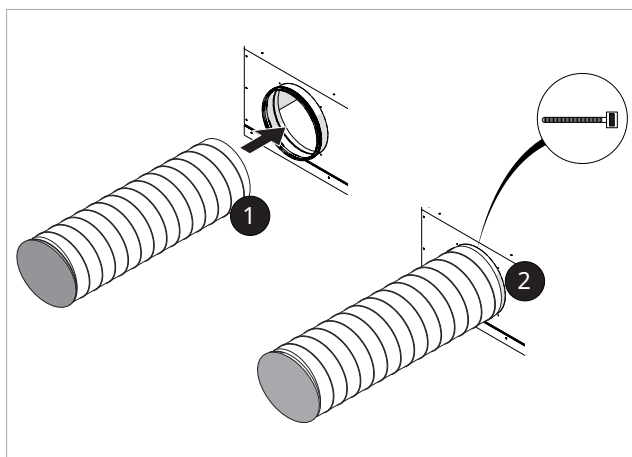

- ▶ position the ducts on the connections provided on the appliance
- ▶ use a metal clamp or duct fixing collar
- ▶ fix the ducts on the attachments
- ⚠ Use ducts lined with anti-condensation material of a suitable thickness.

3.14 Electrical connections

The appliance leaves the factory completely wired and only requires connection to the power supply, the associated external unit, and any accessories.

Preliminary warnings

- ⚠ All operations of an electrical nature must be carried out by suitably qualified personnel having the necessary legal knowledge and informed about the risks related to such operations.
- ⚠ All connections must be made in accordance with the relevant regulations in force in the country of installation.
- ⚠ Before carrying out any work, make sure that the power supply is switched off.
- ⚠ The unit should only be powered after the plumbing and electrical work has been completed.
- ⚠ References:
 - for electrical connections please refer to the wiring diagrams in this manual, especially for the part concerning the power terminal board
- ⚠ Check that:
 - the main supply characteristics are adequate for the power consumption of the appliance, also taking into account any other machinery in parallel operation
 - the power supply voltage and frequency correspond to those specified on the nameplate of the appliance
 - the cables are suitable for installation in accordance with the IEC standards in force
 - the power supply is adequately protected against overloads and/or short circuits
 - the disconnection device is positioned in an easily accessible place to enable intervention in the event of an emergency
- ⚠ It is mandatory:
 - to connect the appliance to an effective grounding system
 - for units with three-phase power supply, check the correct phase connection
 - provide an all-pole switch with a contact opening distance of at least 3 mm that allows complete disconnection under overvoltage category III conditions
 - Install a ground fault circuit interrupter (GFCI). Failure to install this device could result in electric shock
- ⚠ Ensure that a connection to earth is made. Do not ground the appliance to distribution pipes, surge arresters or the ground of telephony systems. If not performed correctly, grounding can cause an electric shock. Momentary high voltage surges caused by lightning or other causes could damage the heat pump.
- ⚠ Ensure that a connection to earth is made. Do not ground the appliance to distribution pipes, surge arresters or the ground of telephony systems. If not performed correctly, grounding can cause an electric shock. Momentary high voltage surges caused by lightning or other causes could damage the heat pump.
- ⚠ Use a dedicated power supply circuit. Never use a power supply to which another appliance is also connected due to risk of overheating, electric shock or fire.

- ⚠ For the electrical connection, use a cable of sufficient length to cover the entire distance without any connection. Do not use extension cables. Do not apply other loads on the power supply.
- ⚠ After connecting the interconnection and power supply cables, ensure that the cables are arranged so that they do not exert excessive forces on the covers or electrical panels. Install the covers on the cables. Incomplete connections of the covers can lead to overheating of the terminals, electric shock or fire.
- ⚠ Any replacement of the power cable must only be carried out by qualified personnel and in accordance with current national regulations.
- ⚠ The manufacturer is not liable for any damage caused by the lack of earthing or failure to comply with the specifications in the respective diagrams.
- ⚠ The appliance is equipped with a noise filter as required by current regulations. Use selective residual current circuit breakers to compensate for the micro leakage to earth of this device.
- ⊖ Using gas and water pipes to ground the appliance is prohibited.

Preliminary warnings for R32

- ⚠ The R32 refrigerant gas is mildly flammable and odourless.
- ⚠ All precautions regarding the handling of refrigerant must be followed in accordance with current regulations.
- ⚠ Avoid proximity to continuously operating ignition sources (open flames, gas appliances, electric stoves, lit cigarettes, etc.).
- ⊖ Smoking is prohibited near the appliance.
- ⊖ The use of mobile phones is prohibited near the appliance.
- ⚠ Perform the following checks:
 - Perform safety checks to ensure that the risk of combustion is minimised
 - avoid working in confined spaces
 - delimit the area around the workspace
 - ensure safe working conditions around the area by checking for flammable materials

Power line dimensioning

Use the tables below for the sizing of the power supply line and its protection device.

These are not average draw or transient peaks, but values to be considered for the correct sizing of the plant and the request of the contractual power (excluding loads due to the normal operation of the building).

- ⚠ Maximum power is reached only in exceptional cases. Therefore, the indicated trip current is suggested to guarantee a balance between machine absorption and incidence in the general system.
- ⚠ The indicated minimum cable cross-section area must be verified according to the actual conditions of the installation: length of the cable, characteristics of the electrical supply, etc.
- ⚠ For units equipped with electrical heating elements, the draw values of the units must be added to those of the heating elements shown in the following tables.

Installation

Access to the electrical panel

- ⚠ Access to the electrical panel is only permitted to qualified personnel.
- ⚠ Before carrying out any work, ensure that the power supply is switched off.

1. Electrical connections passthrough

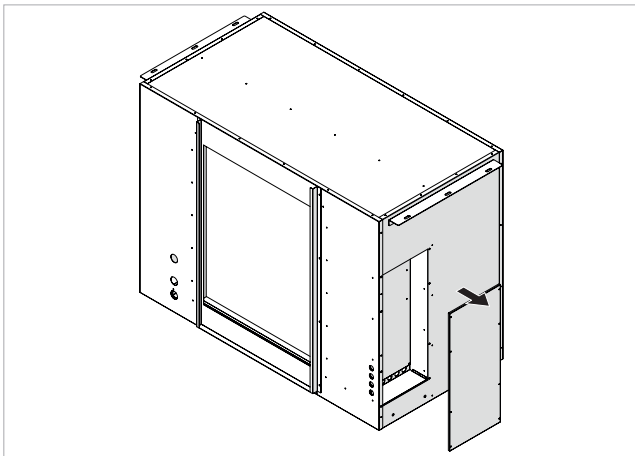
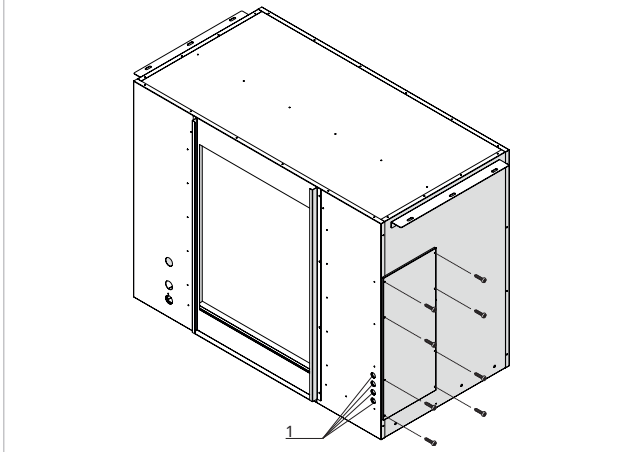

To access the connections:

- ▶ undo the fixing screws
- ▶ remove the electrical panel closing panel

Connections

Before connecting the unit to the mains power supply, make sure that the isolator is open. The power supply of the unit (single phase or three phase) must be connected to the appropriate terminals, subjected to the action of the isolating switch.

- ⚠ Use properly sized cables to avoid voltage drops or overheating.
- ⚠ Use a cable with a minimum cross-section of 1.5 mm² and adequate insulation to ensure a secure seal in the cable glands.
- ⚠ Before making the connection to the terminals, carefully read the information provided in this manual.

Connection diagram

Single connection diagram

1.	Unit	5.	Outdoor unit
2.	Remote control	6.	Isolator
3.	Wired controller communication cable	7.	Power supply 230/1/50 and 400/3/50 according to the model.
4.	External unit communication cable		

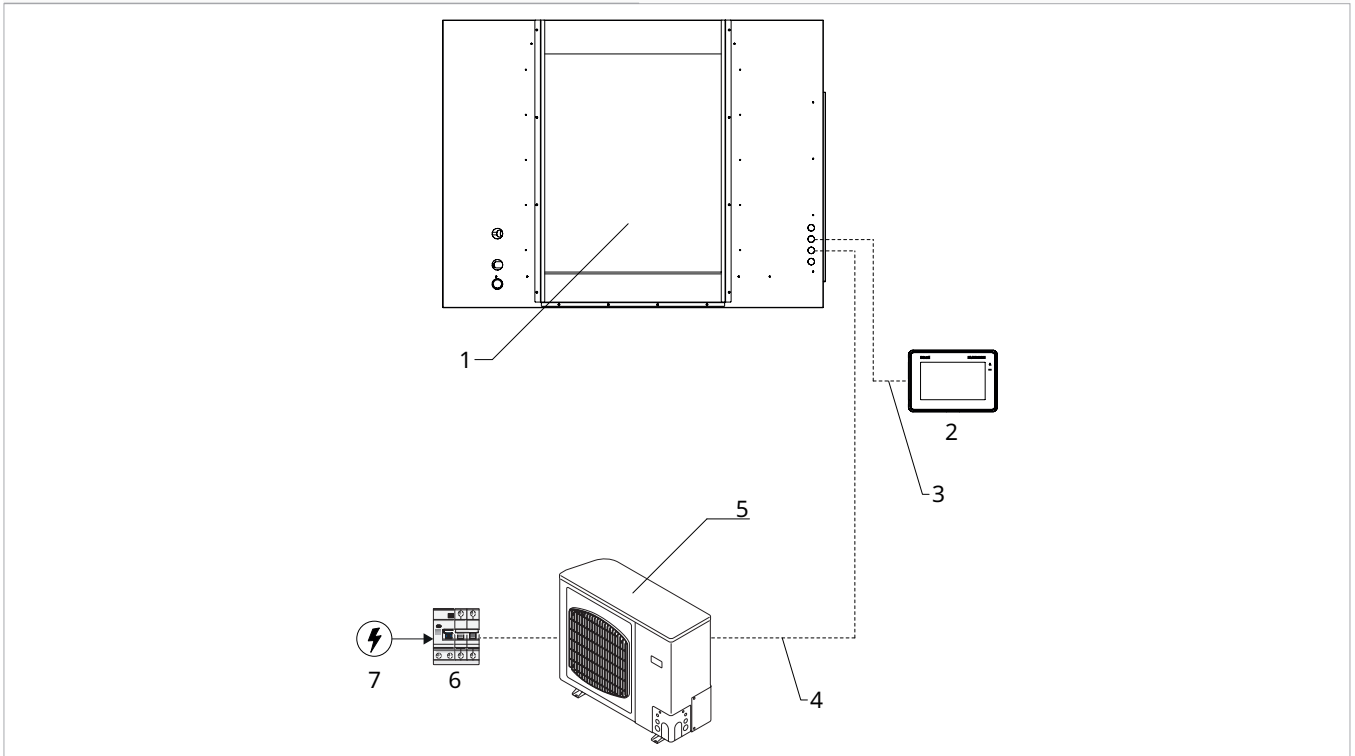

On-board electrical panel

Connection terminal board

A	X2 Terminal block	D	Input connection
B	External unit connection	E	Output connection
C	Panasonic central control connection	F	Connection of the control panel

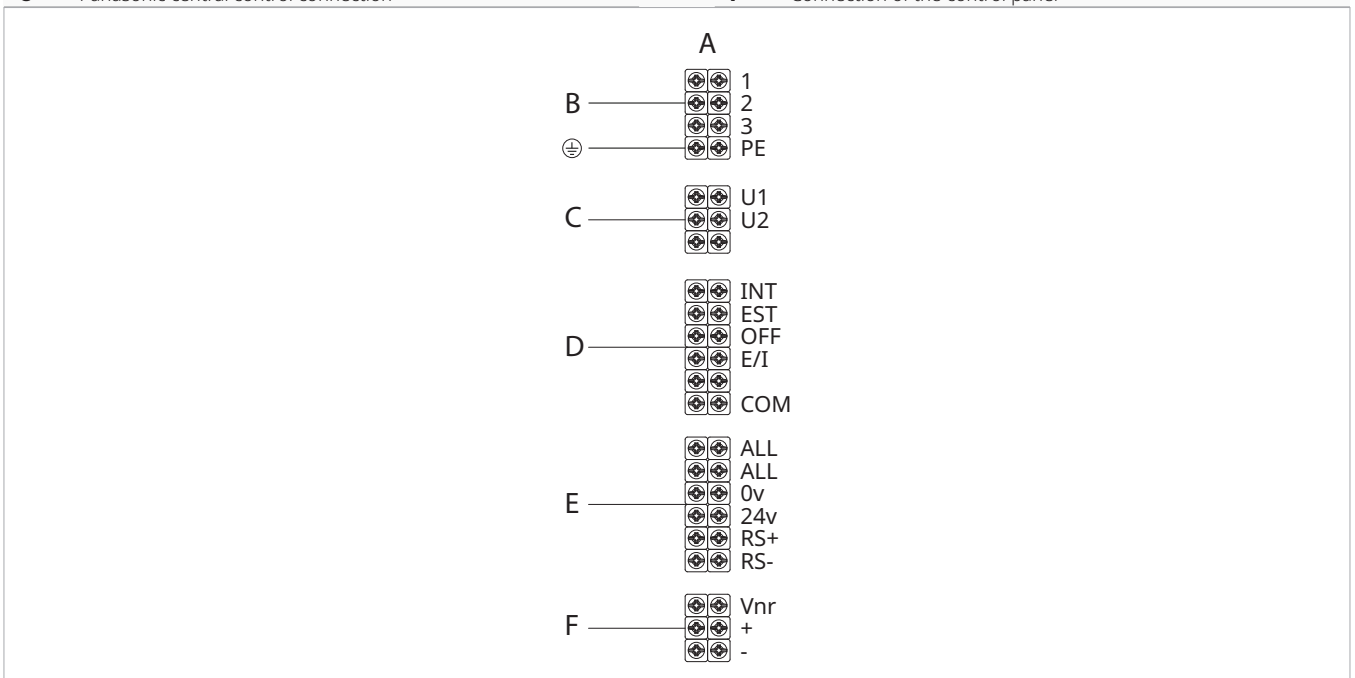

Installation

External unit connection

The external unit is controlled through 3 wires with 230V voltage and the earth connection:

- 1
- 2
- 3
- PE

1. External unit communication

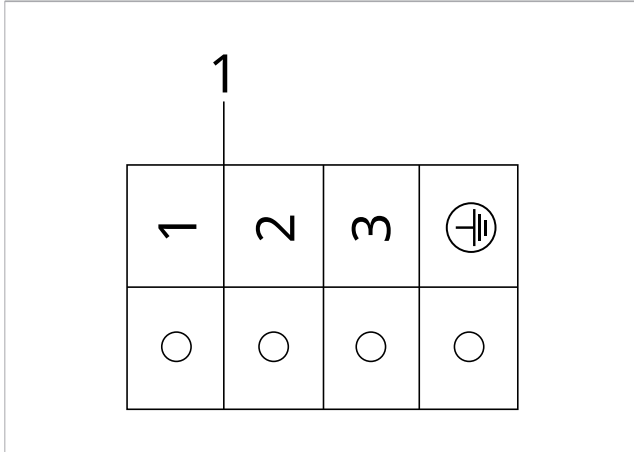

Connection of Control Sensor (Optional)

The unit allows the connection of a remote control sensor to detect a more accurate temperature, particularly useful in installations with significant height.

The sensors use NTC technology with a two-wire connection and can be mounted inside a blind module of an electrical box.

- ⚠ The remote sensor presence parameter must be enabled during the initial startup phase of the unit.
- ⚠ A shielded two-wire cable of 2 x 0.5 mm² or 2 x 0.75 mm² must be used, ensuring that the cable length for each sensor does not exceed 50 meters.
- ⚠ When the temperature request contact is active, the unit will enter integration mode even if the sensor detects that the ambient temperature has already reached the setpoint.
- ⚠ The control sensor must be installed away from heat sources, such as radiators, fan coils, stoves, and direct sunlight.

1. Remote room probe

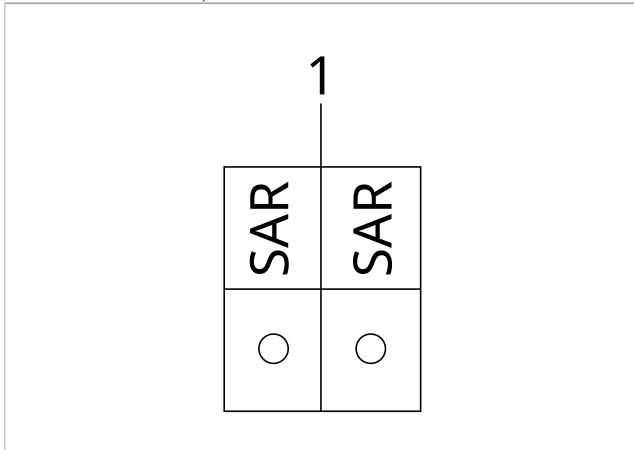

Input connection

Temperature request connection

It is possible to connect a thermostat to the unit that includes forcing the unit into integration mode.

A contact is provided through a standard thermostat with a clean output contact.

Contact closed: unit in integration.

⚠ The contact will take priority over the NTC probe.

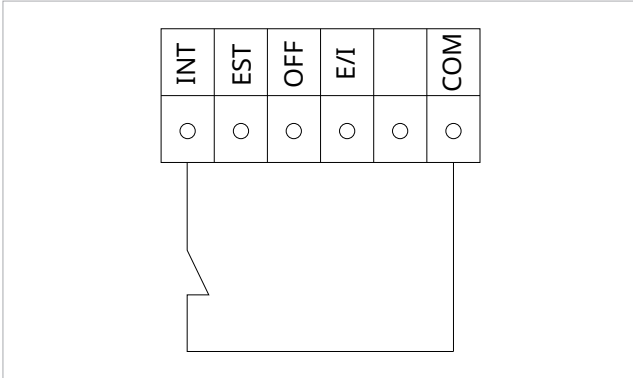

External alarm connection

The unit can signal an external alarm, such as the generator alarm or a pump alarm serving the unit, providing the user with early information about the malfunction.

Closed contact: External alarm signaling activated.

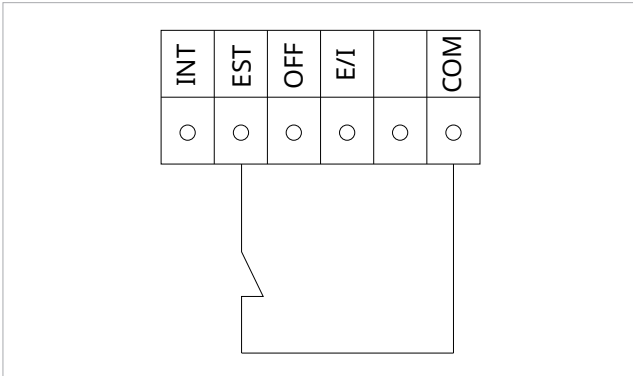

Remote power on/off unit connection

The unit can be connected via a clean contact to a device for remote power on/off, such as a switch or a timer.

With a closed contact, the unit will be ON, and with an open contact, the unit will be remotely forced OFF.

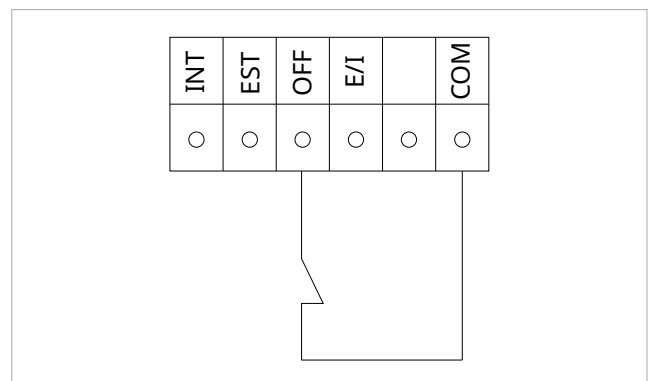

Installation

Summer/Winter connection

The unit can be connected via a clean contact to a device for selecting the operating season. With a closed contact, the unit will be in summer mode, and with an open contact, the unit will be remotely forced into winter mode.

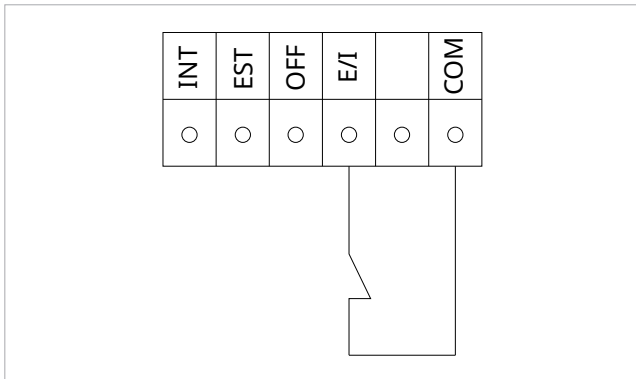

Output connection

Generic alarm signaling connection

The unit can signal a machine alarm through the generic alarm contact; the contact is a clean contact.

Closed contact: Alarm signaling activated.

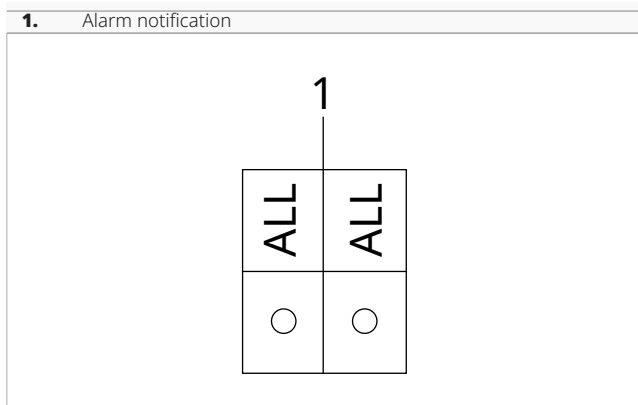

Multiple connection

The unit is designed to connect multiple devices under the same command.

⚠ One controller can control a maximum of 8 devices. Two types of multiple connections are provided:

Multiple wired connection

The network is a Modbus RS485 RTU

- RS (-) RS485 Network
- RS (+) RS485 Network

- Wired RS485 connection
- Wi-Fi connection

Installation

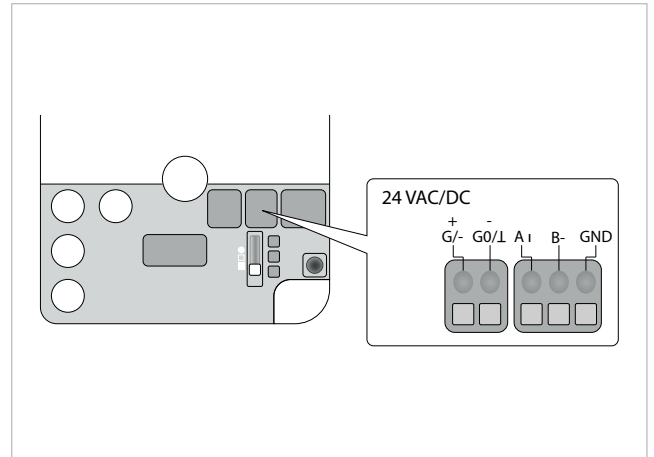
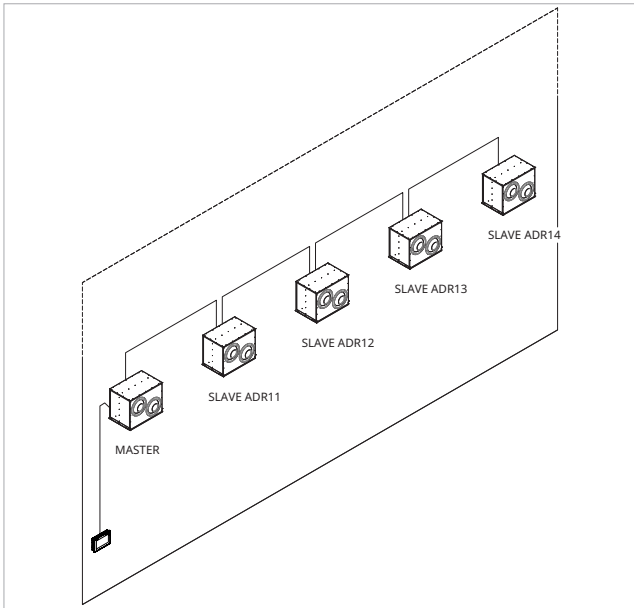

Multiple Wi-Fi connection

For Wi-Fi connection, it's necessary to install a Wi-Fi module to manage multiple connections. The module is installed outside the unit and wired through the terminal block.

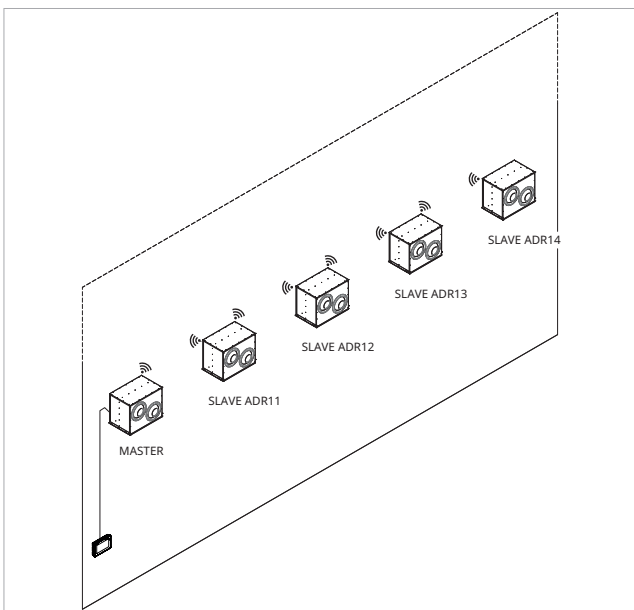

1. 24V AC power supply
2. Modbus RTU

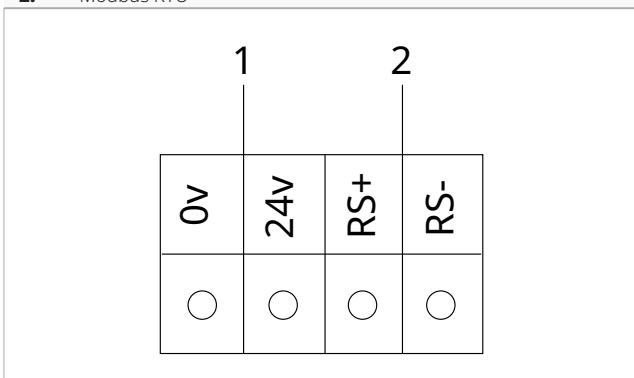

4. REMOTE CONTROL

4.1 Installation

Description

The control panel is a touch screen keyboard that allows control of all the main functions of the device and displays any alarms, with the option of wall-mount or flush-mount installation using the dedicated accessory.

⚠ The controller can control a maximum of 8 devices.

⚠ For operation on the control panel, refer to the manual dedicated to the control panel.

Mounting

1. Mounting hole
2. Electrical cable entry hole

3. Connection terminal board

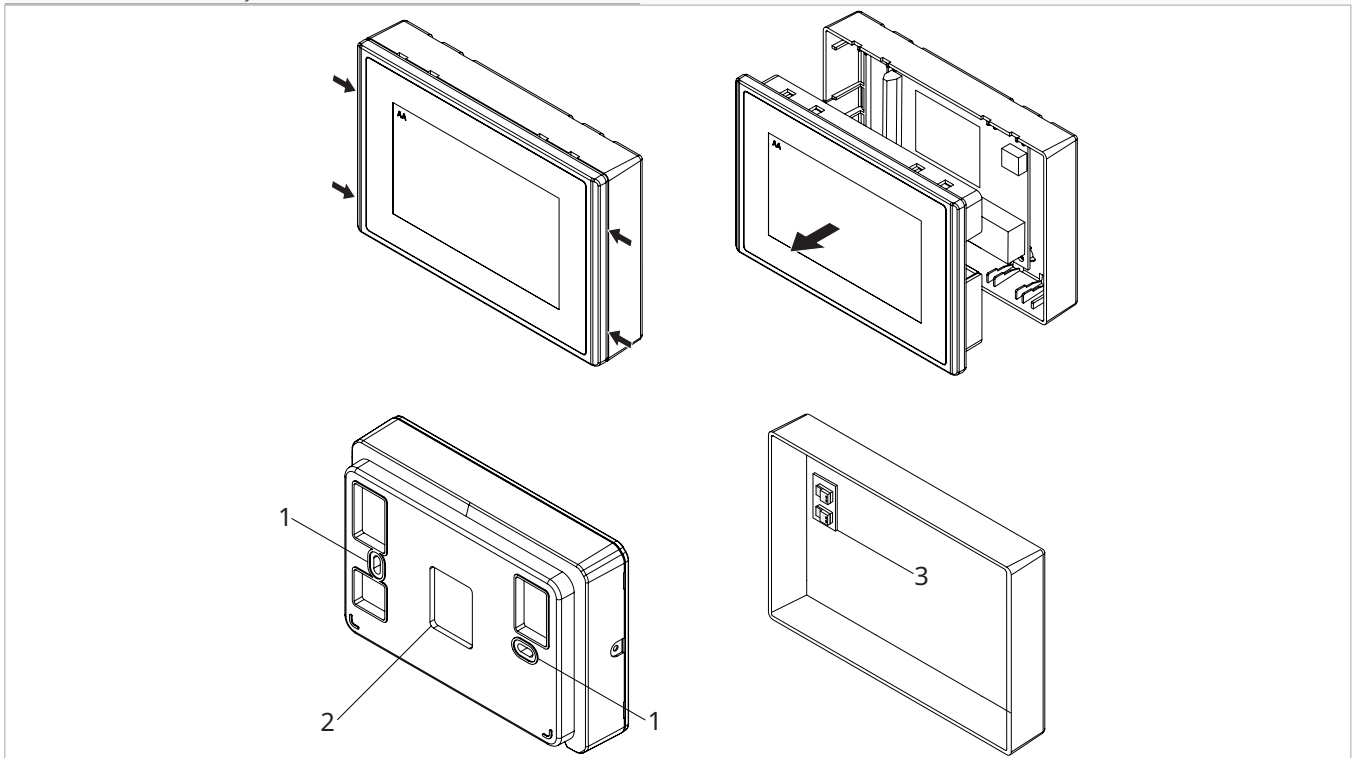

Before mounting on the wall:

- ▶ separate the base from the control panel
 - ▶ use the base as a template to mark out the fixing points
- For wall mounting of the control panel:
- ▶ drill holes in the wall
 - ▶ pass the electrical cables through the prepared hole
 - ▶ fix the base of the control unit to the wall using suitable screws and dowels
 - ▶ make electrical connections
 - ▶ close the control panel

⚠ Take care not to crush the wires when closing the control panel.

4.2 Electrical connections

Terminal board position

A terminal board

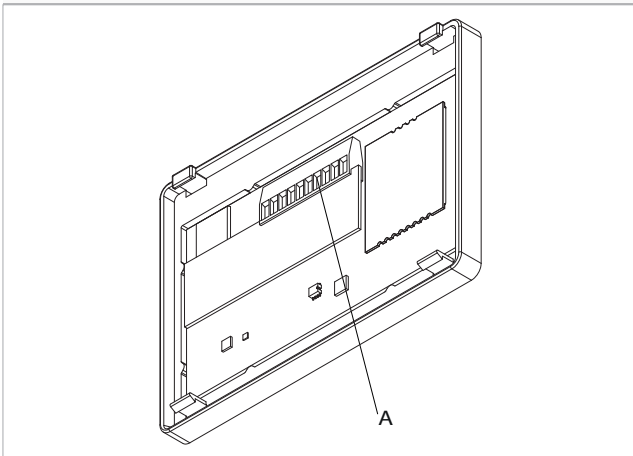

The terminals allow the connection of rigid or flexible cables with cross-sections of 0.2 to 1 mm². For cables equipped with a cable lug with plastic collar the maximum cross-section is reduced to 0.75 mm².

Connection diagram

Connect the control panel to the terminal block provided on the unit.

1. Remote panel

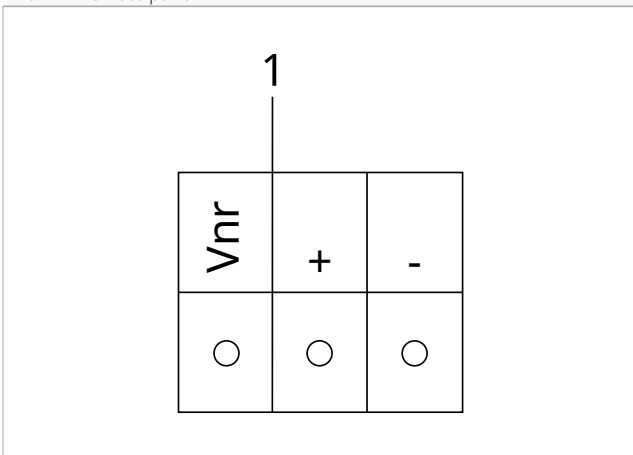

4.3 Interface

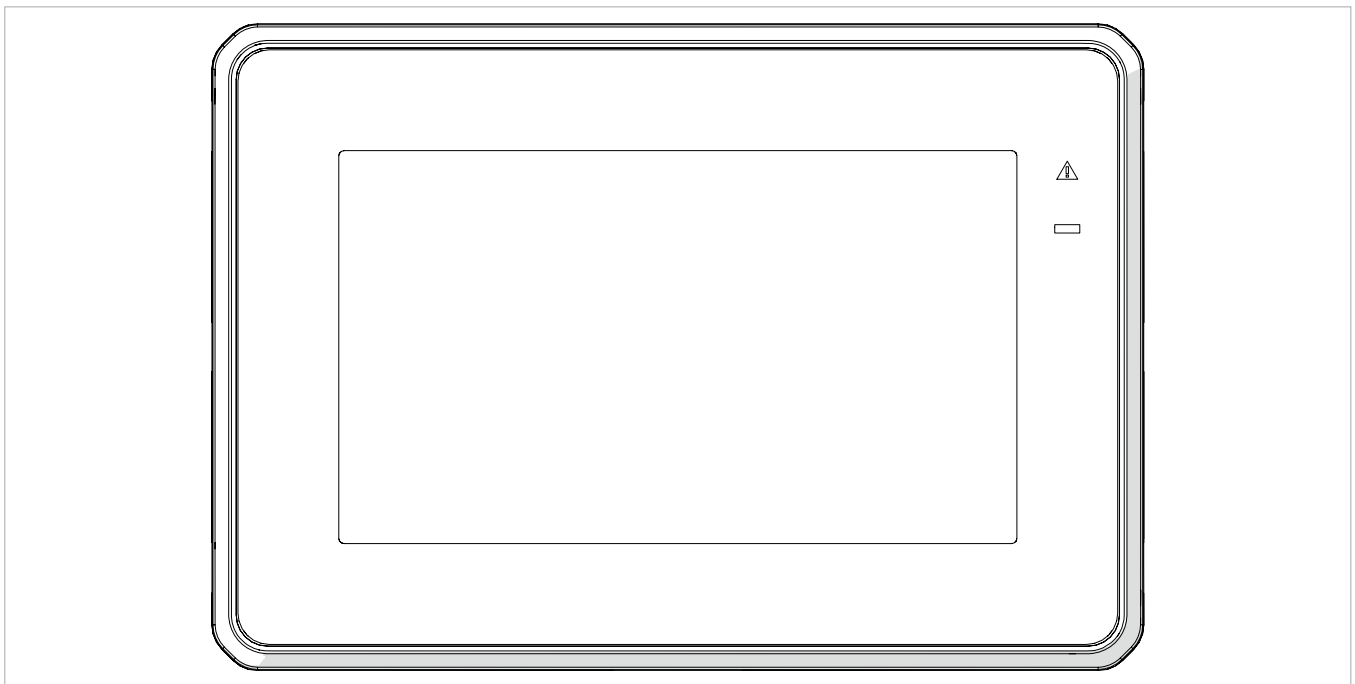

Description

The electronic control panel with a touch interface for wall installation allows:

- adjustment of the room temperature
- management of the main functions of the device
- temperature measurement
- adjustment of the fan speed

Features:

- display of the return air temperature
- internal memory with data storage even in the event of abnormal shutdown or power failure

the multi-unit configuration allows linking multiple units under a single command, offering two connection options:

- modbus, cable connection via Modbus for each individual unit
- Wi-Fi, module for radio communication between units (optional)

⚠ After 300 seconds from the last action, the brightness of the control panel reduces. Pressing any key restores the maximum brightness.

5. CONTROL PANEL - MENU STRUCTURE

5.1 Overview of the structure

Basic menu

It contains: the parameters most commonly used by the user

Advanced menu

..... User functions

It contains: the parameters that the user can modify according to the needs of the system

..... Installer (installer functions)

It contains parameters that only the installer or qualified personnel can modify

..... Parameters (service functions)

It contains the most advanced parameters that only the Technical Support Center can modify

5.2 Details of the structure

Basic menu

..... Power on and off

ON
OFF

..... Fan speed selection

Speed 1
Speed 2
Speed 3

..... Desired temperature settings

Min: 10°C
Max: 30°C

..... Alarm display and reset

Advanced menu

..... User functions

▶ Temperatures

▶ Operating mode display

Active ventilation
Active cooling
Active heating

- ▶ Display of sensor temperatures
- ▶ Component operation statuses
- ▶ Time bands
 - ▶ Date and time settings
 - ▶ Activating / deactivating time bands
 - ▶ Setting time bands
 - ▶ Setting time band on day
- ▶ Season
 - ▶ Operating mode selection
 - # **Cooling**
 - # **Heating**
- ▶ Online guide
 - ▶ Maintenance information
- ▶ Touch (local settings)
 - ▶ Language
 - ▶ Date and time
- ▶ Trend (alarm history)

|..... **Installer (installer functions)**

- ▶ In / Out (status of digital inputs and outputs)
 - ▶ Sensors
 - ▶ Analog outputs
 - ▶ Digital inputs
 - ▶ Relay
- ▶ Settings (system configuration)
- ▶ Modbus Configuration

|..... **Parameters (service functions)**

6. START-UP

6.1 Preliminary warnings

⚠ **This section is dedicated to the Authorised Service Centre. The specifications of the Authorised Service Centre are described in chapter "Recipients" p. 5.**

⚠ **Initial commissioning must be carried out by the Authorised Service Centre.**

⚠ **For detailed information on accessories, please refer to the relevant instruction sheets.**

See chapter "Compatible accessories" p. 13

⚠ The customer must be present when the appliance is tested and informed of the contents of the manual and procedures. After commissioning, the manual and the warranty certificate must be handed over to the customer.

⚠ Before start-up, all works (electrical, hydraulic and air-flow connections) must have been completed.

Preliminary warnings for R32

⚠ The unit uses R32 refrigerant, with a Global Warming Potential (GWP) of 675. Do not release R32 gas into the atmosphere.

⚠ The R32 refrigerant gas is mildly flammable and odourless.

⚠ All precautions regarding the handling of refrigerant must be followed in accordance with current regulations.

⚠ Avoid proximity to continuously operating ignition sources (open flames, gas appliances, electric stoves, lit cigarettes, etc.).

⊖ It is prohibited to use means to speed up the defrosting process or for cleaning other than those recommended.

⊖ Smoking is prohibited near the appliance.

⊖ The use of mobile phones is prohibited near the appliance.

⊖ It is forbidden to introduce objects and substances through the openings provided for the intake and delivery of air.

⚠ Perform the following checks:

- Perform safety checks to ensure that the risk of combustion is minimised

- avoid working in confined spaces

- delimit the area around the workspace

- ensure safe working conditions around the area by checking for flammable materials

Leak detection

⊖ Using combustion-based refrigerant fluid detectors, such as a halide torch or any other system using an open flame, is prohibited.

⚠ For leak detection, follow the following instructions:

- use electronic detectors to search for flammable refrigerant fluids

- before usage, ensure the detectors are properly calibrated

- calibration operations must be carried out in an area free from refrigerant fluid

- ensure the detector is not a potential ignition source and is suitable for the refrigerant fluid used

- if a leak is suspected, all open flames must be eliminated

- in the event of a leak requiring brazing, it is mandatory to recover all refrigerant fluid from the system or isolate it (using shut-off valves) in a part of the system away from the leak

⚠ The use of silicone sealant can compromise the effectiveness of certain types of leak detection instruments.

6.2 First start-up

Preliminary Checks

Before commissioning, check that:

Operational checks

- all safety conditions have been met

- the unit has been properly secured to the supporting surface or wall

- the minimum technical spaces have been observed

Electrical checks

- the cross-section of the power supply cables is adequate for the absorption of the appliance and the length of the connection made

- grounding is correctly performed

- the electrical connections have been established correctly

- all electrical connections are properly secured and all terminals are adequately tightened

- the voltage is within a tolerance of 10% compared to the unit's nominal voltage

- the power supply for the three-phase models has a maximum phase imbalance of 3%

- all control wires are connected and that all electrical connections are secure

Refrigerators

- the refrigerant connections have been made following the instructions provided in the manual
- the shut-off valves of the refrigeration circuit are open

Powering up

⚠ Before starting, power up the unit for at least 12 hours.

⚠ Make sure that the control panel is switched off.

To power up the unit:

- ▶ set the main switch to ON

The display will light up a few seconds after powering up. Check that the operating status is OFF.

⚠ For performing operations, refer to the Control Panel Manual.

Start-up

After all checks have been carried out, the unit can be put into operation.

To activate the appliance:

- ▶ please refer to the user manual

6.3 Plant delivery

Once all the checks and controls on the correct operation of the plant have been completed, the installer must explain the following to the user:

- the basic functional characteristics of the appliance

Checks with the machine switched on

After starting up, check that

Operational checks:

- verify the different modes of operation
- verify that the appliance stops and then restarts
- switch the appliance off and on again and check that it restarts correctly
- the appliance operates within the recommended operating conditions (see technical specifications table)
- check that the air flow rates are correct

Hydraulic Checks

- check for proper condensate drainage

Electrical Checks

- the current absorbed is less than the maximum indicated in the technical data table
- the supply voltage value is within the set limits and does not fall below the nominal value -10 % during operation

6.4 Switching off for extended periods

If the appliance is not used for a long period of time, the following steps must be taken:

- ▶ deactivating the device
- ▶ isolate the power supply

⚠ To restart the appliance after it has been out of use for a long period, call in the Authorised Service Centre.

6.5 Control settings

Control panel of the indoor unit

Advanced menu

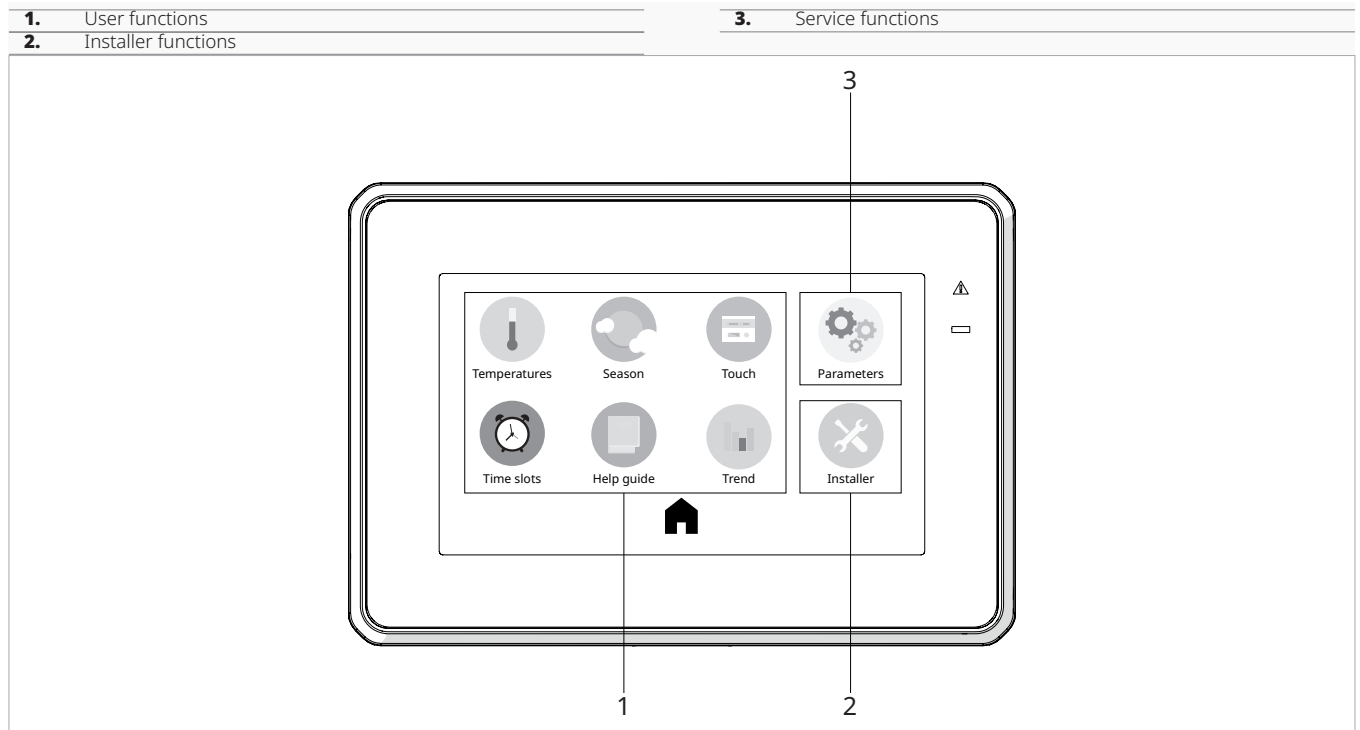

To access the advanced menu

- ▶ hold down the button

To return to the basic menu

- ▶ hold down the button

Installer (installer functions)

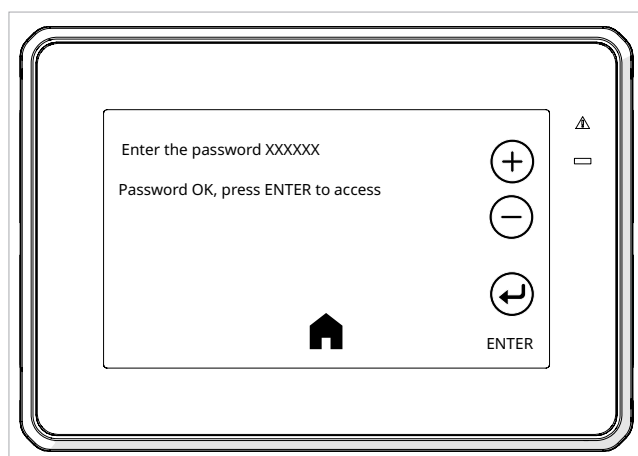

- ⚠ The entrance to the installer menu requires entering the password

To access the installer menu

- ▶ hold down the button
- ▶ press the password input value

act on the and buttons to change the value

To confirm the selection

- ▶ hold down the button
- the message 'Correct Password' appears*

To access the installer menu

- ▶ hold down the button

- ⚠ If the password value is incorrect, the display will remain in the password setting, and the steps listed above will need to be performed again.

- ⚠ **The programming operations of the parameters in the installer menu can modify some functions and logics of the unit. Be careful with the changes made; the manufacturer is not responsible for any modifications that do not guarantee the technical performance declared by the unit.**

In / Out

To access the in / out menu

- ▶ hold down the button 

To navigate from one screen to another

- ▶ press the buttons  and 

To return to the main menu

- ▶ hold down the button 

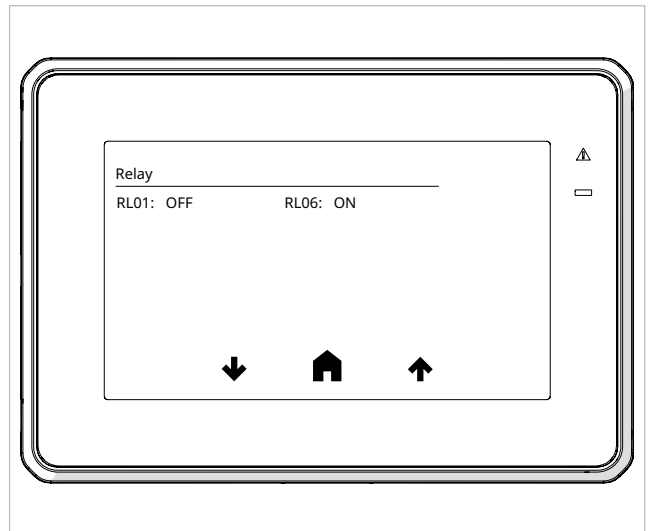
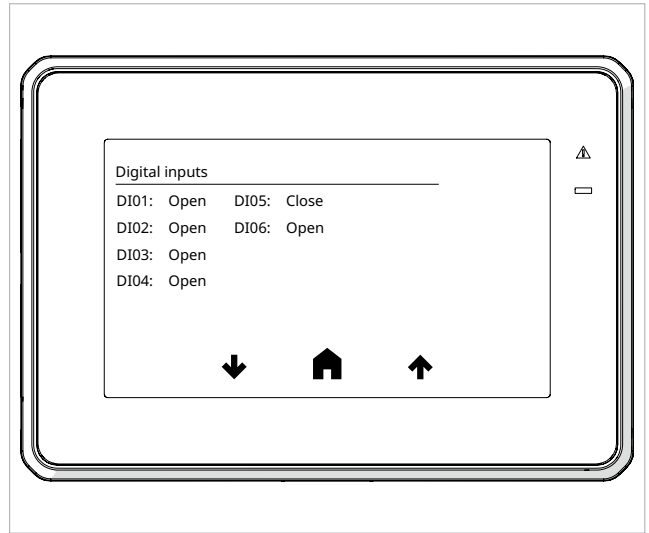
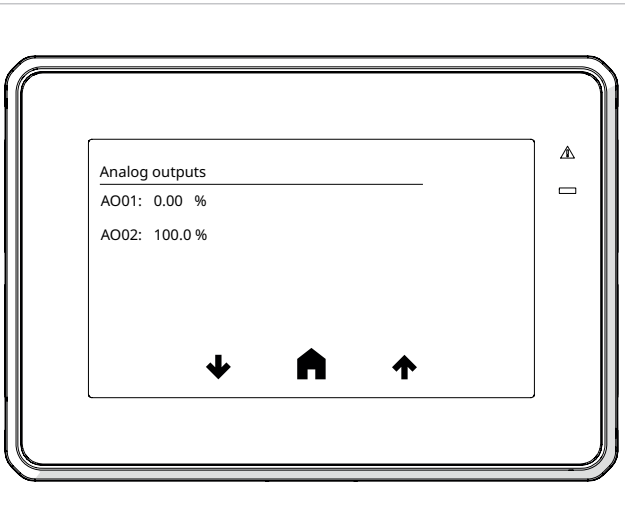
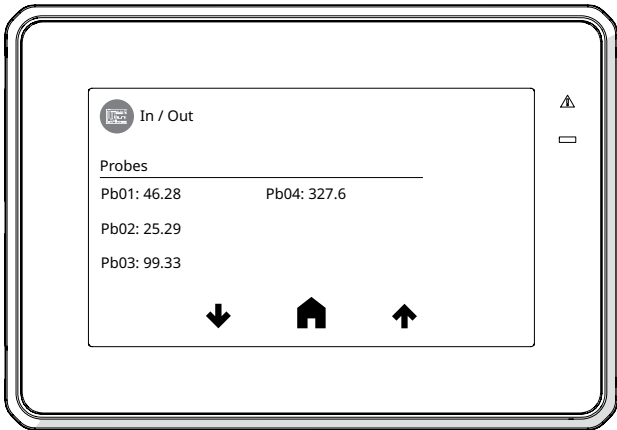



Settings

To access the settings menu

- ▶ hold down the button 



To navigate from one screen to another

- ▶ press the buttons  and 

To set the desired value

- ▶ select the value

To enable editing

- ▶ hold down the button 
- ▶ operate the  and  buttons to decrease or increase the desired value

To confirm

- ▶ hold down the button 

To return to the main menu

- ▶ hold down the button 

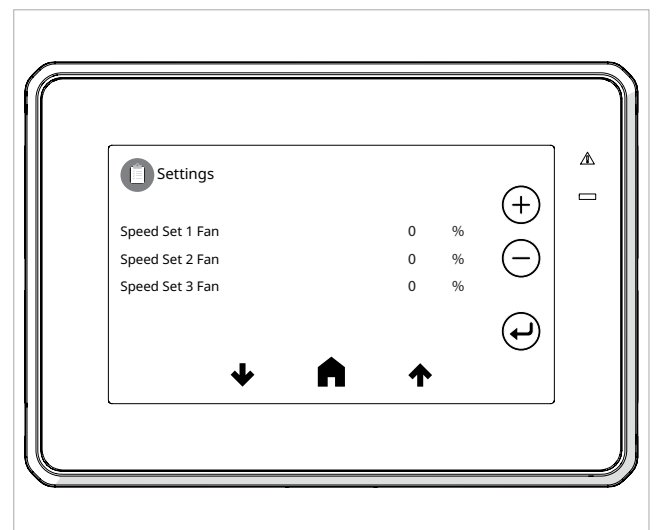
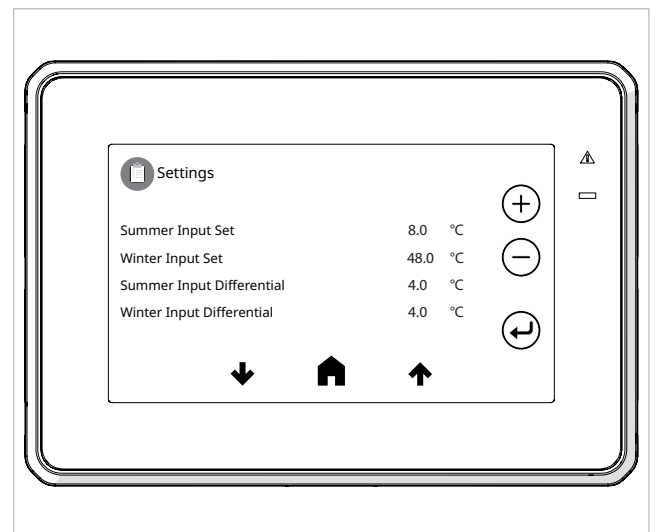
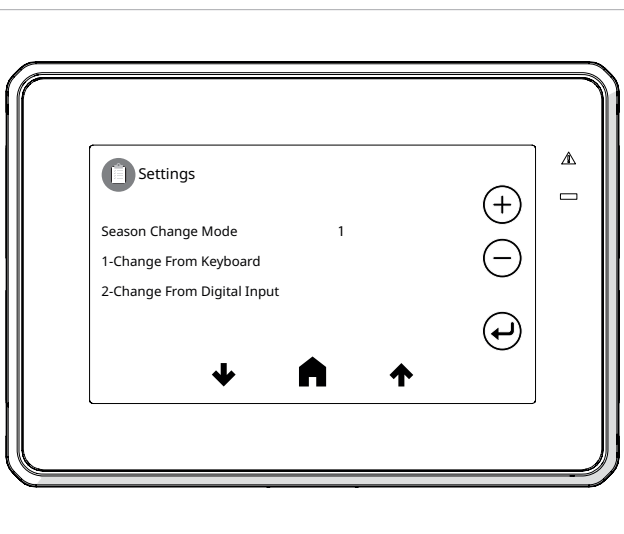
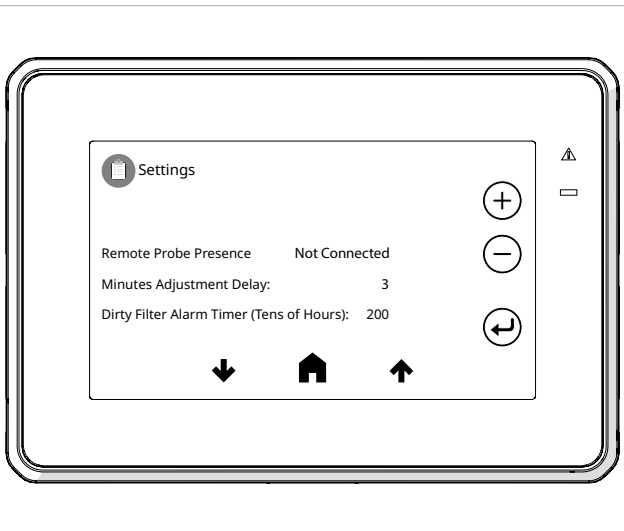

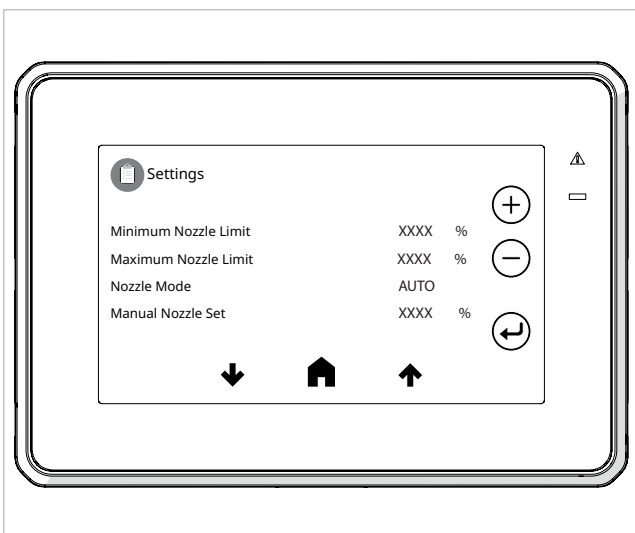
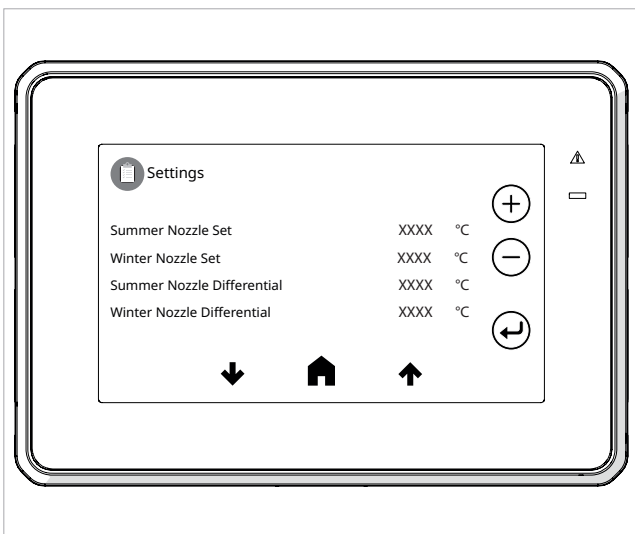
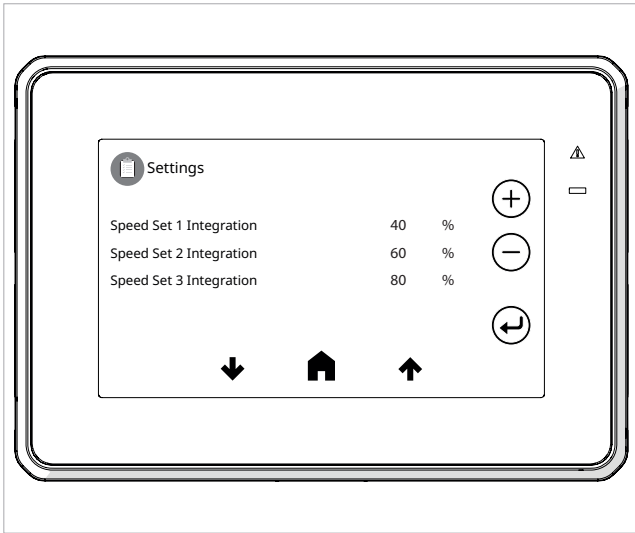

Modbus Configuration

To access the Modbus port configuration menu

- ▶ hold down the button

To navigate from one screen to another

- ▶ press the buttons and

To set the desired value

- ▶ select the value

To enable editing

- ▶ hold down the button
- ▶ operate the and buttons to decrease or increase the desired value

To confirm

- ▶ hold down the button

To set up the master unit

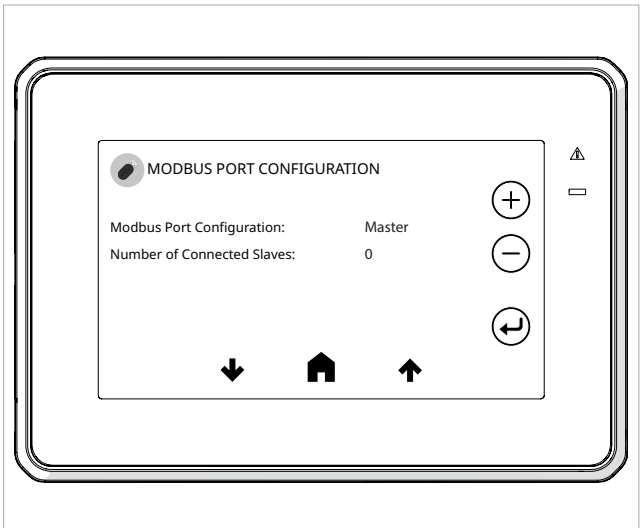

- ▶ select Master
- ▶ specify the number of slave units connected to the master

To set up the slave unit

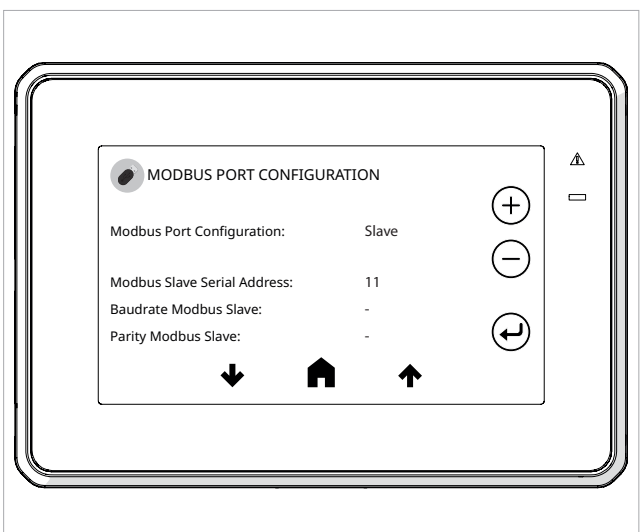

- ▶ select Slave
- ▶ enter the serial address of the unit

⚠ The first slave unit corresponds to serial address 11, the second to 12, and so on.

To confirm

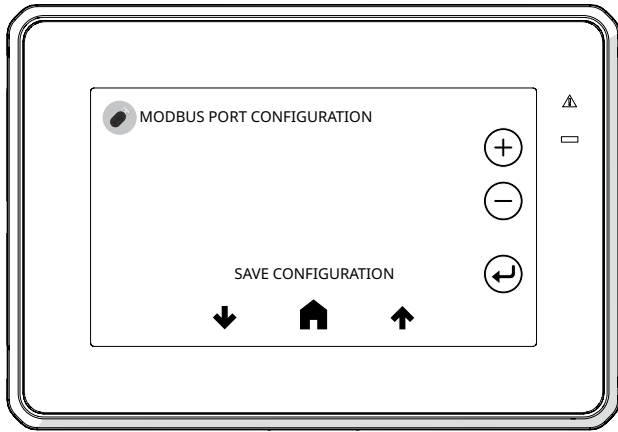

- ▶ press Save configuration
the control panel is restarting

To return to the main menu

- ▶ hold down the button

External unit control panel

Position

1. External unit control panel

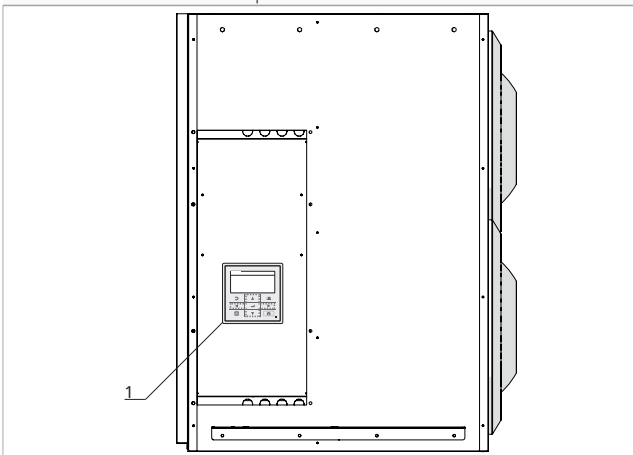

Remote control

- ⚠ The external unit control panel is not a remote control.
- ⚠ The control panel of the external unit is solely used during the initial commissioning to perform the automatic address setting and the initial startup. After that, do not press any other button, do not turn off, or attempt programming.

1. Enter button
2. Power button
3. Operation LED indicator (illuminates during operation/flashes during an alarm)
4. Back button
5. Selection button

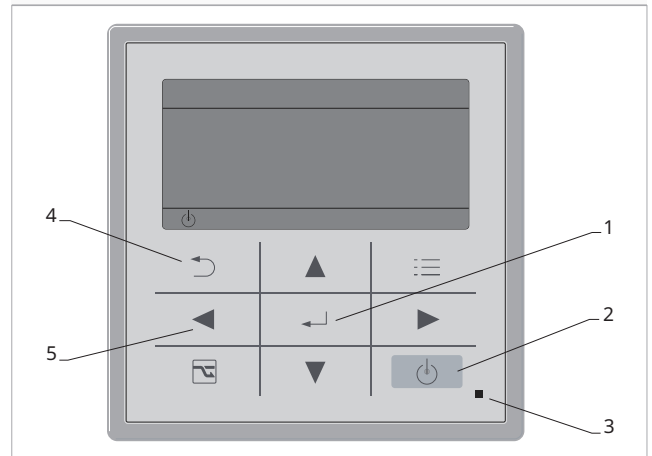

Automatic address setting

Before starting the Assigning procedure:

- ▶ verify that the electrical connections between the outdoor unit and indoor unit at terminal block J6 have been correctly made.

A Stand-by screen

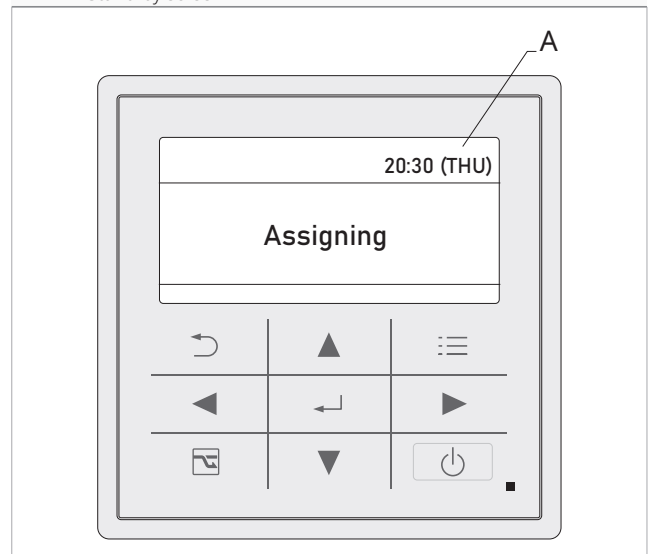

To start the Assigning procedure:

- ▶ power up the device electrically
On the display, "Assigning" appears
The Assigning procedure starts

- ▶ wait a few minutes

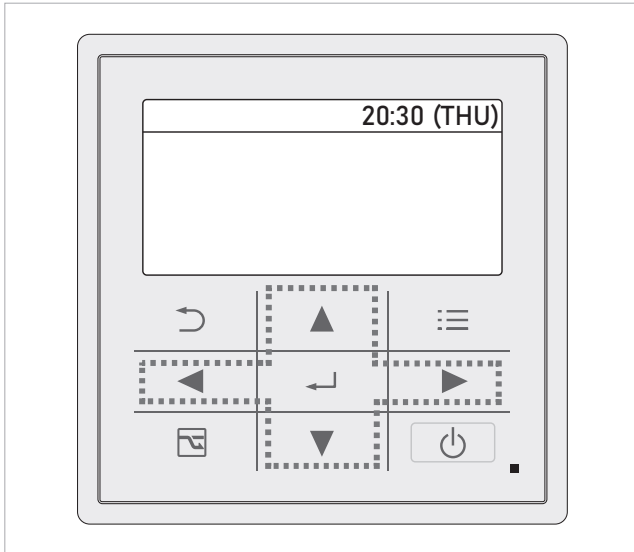

*Assigning disappears from the display
The Assigning procedure has completed*

- ▶ wait a minute
 - ▶ proceed with turning on using the control panel of the indoor unit
- ⚠ If the Assigning procedure doesn't restart automatically or the symbol ⚠ along with R.C.1 remains displayed, contact the Technical Assistance Center.
- ⚠ If the ⚠ symbol accompanied by R.C.1 is displayed during the Assigning procedure, remove power from the device.

Meaning of the light indicators on the electronic board of the external unit

Meaning	LED 1	LED 2
absence of communication with the internal unit	○	○
communication established with the internal unit	●	○
normal communication OK (power and validating quantity)	●	●
automatic address setting in progress	☀	☀

- switched on
- switched off
- ☀ alternative flashing

Initial start-up of the external unit control panel

- ▶ press ⏻

A Display on

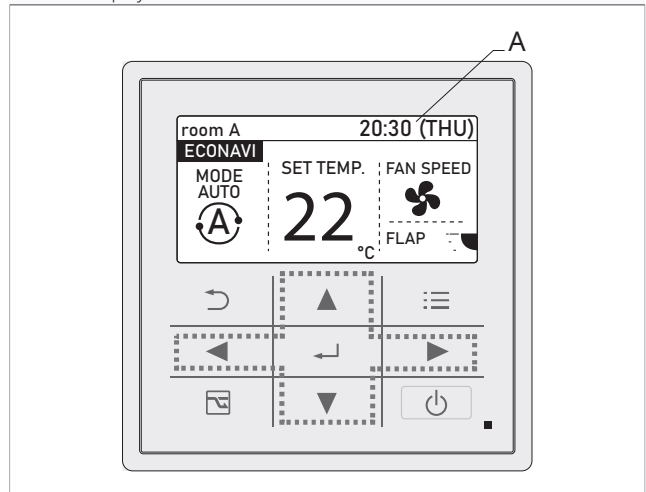

- ▶ press ◀
- ▶ Select MODE
- ▶ press ↵
- ▶ press ⬆
- ▶ select the auto mode
- ▶ press ↵
- ▶ wait a few seconds
- ▶ ☀ appears on the display.
- ▶ wait a few seconds
- ▶ remove and restore power to the device
- ▶ verify that the settings have been stored

Checks during and after the initial commissioning

After starting up, check that

- the absorbed current of the device is lower than the maximum indicated in the manual of the internal unit
- ⚠ During compressor operation, the electrical voltage should not drop below the nominal value of -10%.
- the appliance operates within the recommended operating conditions
- the hydraulic circuit is completely de-aerated
- the hydrometer pressure is between 1 and 2 bars
- the air-to-water heat pump performs a shutdown and subsequent restart
- the temperature difference between supply and return in the system is between $4 \div 7$ °C.
- ⚠ If the temperature difference is below 4 °C, set a lower circulation pump speed.
- ⚠ If the temperature difference exceeds 7 °C, check the opening of all valves in the system and consider adding an external pump to increase water flow.
- switch the appliance off and on again and check that it restarts correctly

7. MAINTENANCE

7.1 Routine maintenance

Preliminary warnings

Before any cleaning or maintenance intervention:

- ▶ Disconnect the device from the electrical network by setting the main switch of the system to "OFF"
- ▶ wait for the components to cool down to avoid the risk of burns
- ⊖ Any technical or cleaning intervention is prohibited before disconnecting the unit from the power supply.
- ⚠ Check for the absence of voltage before performing any operation.
- ⚠ After performing the necessary maintenance operations, restore the original conditions.
- ⚠ It is forbidden to introduce objects and substances through the openings provided for the intake and delivery of air.
- ⚠ Handle the refrigerant with care. Leaking refrigerant can cause frostbite.
- ⚠ For safety and installation requirements relating to the outdoor unit and overall system installation, please refer to the relevant outdoor unit documentation.

Annual operations

The once-a-year maintenance plan includes the following operations and checks and must be carried out by the Authorised Service Centre or by qualified personnel.

Electrical circuit

Check:

- electrical supply voltage
- the electrical absorption
- tightening connections
- that there is no damage or excessive wear to electrical cables
- that the gaskets and sealing materials have not deteriorated to such an extent that they are no longer suitable for the purpose of preventing the development of flammable atmospheres inside
- the correct fixing of cable glands
- safety devices

Mechanical checks

Check:

- tightening of the screws, fans and electrical box, of the unit's external panelling
- the state of the structure
- ⚠ Bad fixings result in abnormal noise and vibration.
- ⚠ If oxidised parts are present, treat them with suitable paints to eliminate or reduce oxidation.

Hydraulic controls

Check:

- the regular drainage of condensate
- cleaning the condensate collection trays
- cleaning the exhaust ducts

Airflow controls

Check:

- the regular flow of air
- cleaning of any intake grilles
- cleaning the ducting

Cleaning

- cleaning of aesthetic cover
- cleaning or filter replacement
- cleaning the heat exchanger

Cleaning or filter replacement

To remove:

Size 30

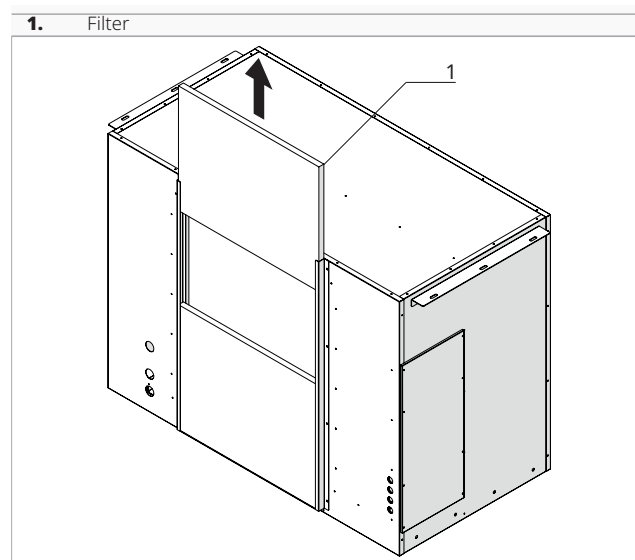

- ▶ isolate the power supply to the unit
- ▶ remove the filter by gently sliding it upwards

To remove the filter from below:

Size 15

1. Lower filter guide
2. Filter

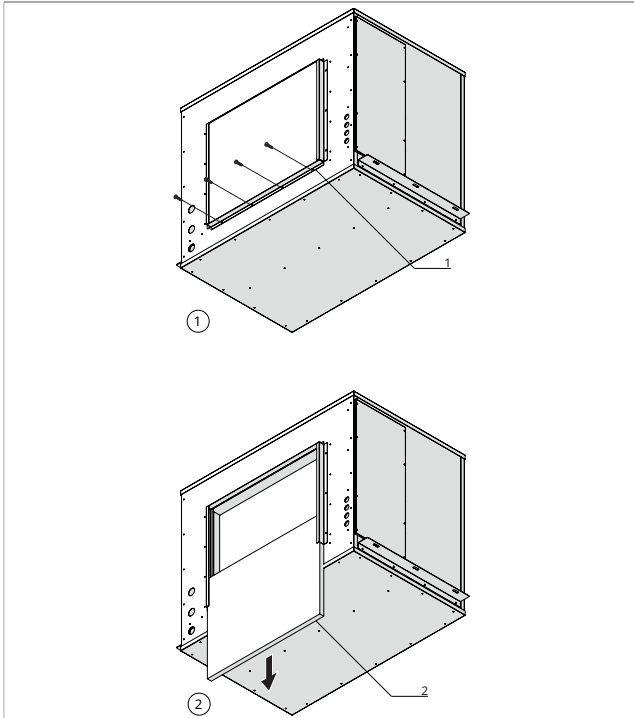

Size 30

1. Lower filter guide
2. Filter

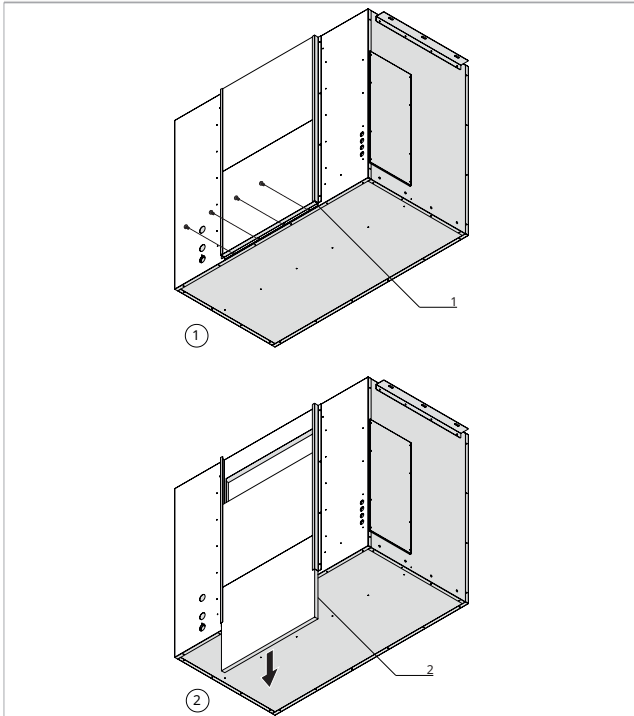

- ▶ isolate the power supply to the unit
- ▶ remove the screws from the lower filter guide
- ▶ remove the lower filter guide
the filter automatically releases itself

- ⚠ Be careful to avoid damaging the filter during its extraction; maintain a firm yet gentle grip on the filter to ensure safe and controlled removal.
- ⚠ Pay attention to sharp surfaces
- ⓘ **If the condition of the filters is acceptable, they can be cleaned using a vacuum cleaner or a low-pressure compressor.**
- ⓘ **If it is impossible to clean them, the filters must be replaced.**

To reposition:

- ▶ perform in reverse order

Cleaning the heat exchanger

Cleaning the heat exchanger

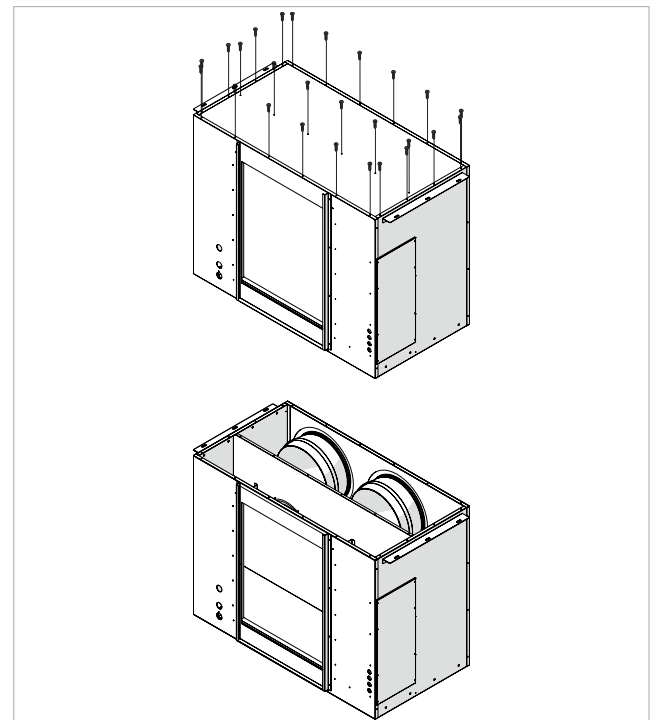

- ▶ isolate the power supply to the unit
- ▶ disconnect the condensate drain pipe
- ▶ remove the filters (see chapter "Cleaning or filter replacement" p. 48)
- ▶ remove the screws from the upper panel
- ▶ remove the top panel
- ▶ gently proceed with cleaning using a vacuum cleaner or a low-pressure compressor
- ▶ reposition the top panel using the screws removed earlier
- ▶ reposition the filters
- ⚠ Never touch the fins of the heat exchanger, handle only the closed sides.
- ⓘ **To prevent dirt from entering the heat exchanger, clean in the opposite direction to the air flow.**

8. DECOMMISSIONING

8.1 Safety warnings

- ⚠ Before carrying out this procedure, it is essential that the technician has a complete understanding of the equipment and all its details.
- ⚠ It is recommended to safely recover all refrigerants.
- ⚠ Before performing the activity, an oil and refrigerant sample must be taken in case an analysis is required before reusing the recovered refrigerant.
- ⚠ It is essential that the power supply is available before starting the activity.
- ⚠ Become familiar with the equipment and its operation.
- ⚠ Electrically isolate the system.
- ⚠ Before attempting the procedure, make sure that:
 - mechanical handling equipment should be available, if necessary, for the handling of refrigerant cylinders
 - all personal protective equipment is available and used properly
 - the recovery process should be supervised at all times by a competent person
 - the recovery equipment and cylinders comply with the appropriate standards
- ⚠ If possible, evacuate the refrigeration system.
- ⚠ If it is not possible to achieve a vacuum, create a manifold so that the refrigerant can be removed from various parts of the system.
- ⚠ Make sure the cylinder is weighed on the scale before the recovery takes place.
- ⚠ Start the recovery machine and operate it according to the manufacturer's instructions.
- ⚠ Do not overfill the cylinders. No more than 80% of the liquid charge volume.
- ⚠ Do not exceed the maximum working pressure of the cylinder, even temporarily.
- ⚠ When the cylinders have been filled correctly and the process is complete, ensure that the cylinders and equipment are removed from the site in a timely manner and that all isolation valves on the equipment have been closed.
- ⚠ The recovered refrigerant must not be charged into another refrigeration system unless it has been cleaned and checked.

9. FAULTS AND REMEDIES

9.1 Preliminary warnings

If one of the following faults is found:

- the appliance is leaking water
- the appliance makes excessive noise
- there is dew formation on the front panel

Follow the instructions below:

- ▶ immediately isolate the power supply

- ▶ close the water valves
- ▶ contact an Authorised Service Centre or professionally qualified personnel
- ⚠ The intervention must be carried out by a qualified installer or an Authorised Service Centre.
- ⊘ Personal intervention is prohibited.

9.2 Anomalies reported by the control panel

Anomalies are reported on the display of the control panel.

⚠ For the reading, refer to the Control Panel Manual.

Manual reset of alarms

If an anomaly repeats multiple times, the device goes into safety mode, and the alarm must be manually reset.

⚠ To restore, refer to the Control Panel Manual.

9.3 Functional aspects not to be interpreted as faults

- During the operation of the device, the following functional aspects may occur. These unit behaviors are to be considered regular and should not be interpreted as anomalies.
- The compressor will not restart until 3 minutes have elapsed since it was switched off.
- While the heat pump appliances are heating up, heat is delivered a few minutes after the compressor is switched on.
- Periodic defrosting cycles occur during heating operation.
- When switching from producing domestic hot water to cooling, and vice versa, the external heat pump remains off for one minute to prevent mixing between hot and cold water.

9.4 Troubleshooting table

ALARM	CAUSE	REMEDY
Extract air probe alarm	The probe is damaged and/or disconnected	Verify that the probe has been connected correctly Replace the probe with a new one
Coil probe alarm	The probe is damaged and/or disconnected	Verify that the probe has been connected correctly Replace the probe with a new one
Supply probe alarm	The probe is damaged and/or disconnected	Verify that the probe has been connected correctly Replace the probe with a new one
Modbus communication alarm	The INN PDC 03 board is not communicating	Verify that the board has been connected correctly Replace the board with a new one
External unit alarm	There is an error on the external unit	Check for errors related to the external unit
SLAVE 1 alarm	Communication error with SLAVE No. 1	Check for the presence of SLAVE 1 Verify the correct connection
SLAVE 2 alarm	Communication error with SLAVE No. 2	Check for the presence of SLAVE 2 Verify the correct connection
SLAVE 3 alarm	Communication error with SLAVE No. 3	Check for the presence of SLAVE 3 Verify the correct connection
SLAVE 4 alarm	Communication error with SLAVE No. 4	Check for the presence of SLAVE 4 Verify the correct connection
SLAVE 5 alarm	Communication error with SLAVE No. 5	Check for the presence of SLAVE 5 Verify the correct connection
SLAVE 6 alarm	Communication error with SLAVE No. 6	Check for the presence of SLAVE 6 Verify the correct connection
SLAVE 7 alarm	Communication error with SLAVE No. 7	Check for the presence of SLAVE 7 Verify the correct connection

9.5 Alarms displayed on the control panel of the external unit

The control panel of the external unit allows for the display of alarms that occur during the operation of the heat pump.

⚠ If the user interface shows the PdC alarm, refer to the Technical Support Center.

Alarms displayed	Cause	Remedy
P03	Abnormal compressor discharge temperature > or = to 103 °C.	Check the refrigeration cycle (possible excessive refrigerant charge). Verify the opening of the refrigerant valves. Check the compressor discharge temperature probe (TD) and replace if necessary.
P04	High-pressure switch intervention on the external unit.	In the summer cycle, check the free circulation of air around the outdoor unit. Verify the refrigerant charge. In the winter cycle, check the opening of the refrigerant valves.
P05	Detection of absence of one phase or incorrect phase connection in the three-phase version. Lack of neutral in single-phase versions.	Check the presence and sequence of the power supply phases R, S, and T, and in single-phase systems ensure the appliance is not powered by two phases.
P10	Missing or disconnected electrical bridge on connector CN034 of the PAW-ACXA73-38670 board.	Check the connection.
P11	Missing or disconnected electrical bridge on connector CN068 of the PAW-ACXA73-38670 board.	Check the connection.
P15	Detection of insufficient refrigerant charge.	Check the refrigeration circuit for potential leaks.
P16	Excessive compressor absorption.	Check resistance values.
P19	4 way valve stuck	Check the power supply and the operation of the 4-way valve.
P20	Refrigerant high-pressure protection.	Check the cleanliness of the external heat exchanger and ensure minimum clearances are maintained. Check fan operation and proper discharge of air from the condenser.
P22	External fan motor malfunctioning. Protection of the external fan inverter circuit activated.	Check for free movement of the fan. Replace the fan motor inverter board.
P26	Intervention of the compressor inverter circuit protection.	Remove and restore power to the appliance and check the correct restart of the compressor.
P29	The compressor is not functioning correctly.	Check the wiring of the Inverter board and replace it if necessary.
H01	Overcurrent detected by the compressor's Inverter board.	The radiant plate cooling issue of the Inverter board. Check the cleanliness of the heatsink. Check the electrical connections of the compressor.
H05	The control board software of the external unit needs updating	Contact the Technical Support Center to arrange for the replacement.
H31	Malfunction of the HIC driver board	Contact the Technical Support Center to arrange for the replacement.
F01	The liquid sensor E1 on the indoor unit is disconnected, interrupted, or short-circuited.	Check the sensor and consider replacing it if needed.
F02	The condensation sensor E2 on the indoor unit is disconnected, interrupted, or short-circuited.	Check the sensor and consider replacing it if needed.
F04	The compressor discharge sensor TD is disconnected, interrupted, or short-circuited.	Check the sensor and consider replacing it if needed.
F06	The liquid sensor C1 on the outdoor unit's coil is disconnected, interrupted, or short-circuited.	Check the sensor and consider replacing it if needed.
F07	The condensation sensor C2 on the outdoor unit's coil is disconnected, interrupted, or short-circuited.	Check the sensor and consider replacing it if needed.
F08	The outdoor temperature sensor TO is disconnected, interrupted, or short-circuited.	Check the sensor and consider replacing it if needed.
F10	The regulation signal connection of the controller is disconnected, interrupted, or short-circuited.	Check the connection of the Tout connector and the controller INN-PDC_03 to the CN104 connector of the PAW-ACXA73-38670 board.
F12	The compressor suction sensor TS is disconnected, interrupted, or short-circuited.	Check the sensor and consider replacing it if needed.
F29	EEProm problem in the outdoor unit.	Switch the appliance off and on again and check for proper operation. Replace the EEPROM of the PAW-ACXA73-38670 board.
F31	EEProm problem in the outdoor unit.	Switch the appliance off and on again and check for proper operation. Replace and reprogram the electronic board of the outdoor unit.
L02	Parameter incompatibility between the indoor and outdoor unit.	Perform the automatic address setting again. Contact the Service for reprogramming.
L08	Lack of settings in the outdoor unit.	
L09	Lack of settings in the outdoor unit.	
L10	Lack of settings in the outdoor unit.	
L13	Incorrect parameter setting in the indoor unit.	

Alarms displayed	Cause	Remedy
L18	Malfunction of 4 way valve. The probes E1 and E2 detect low temperatures during heating. The probes E1 and E2 detect high temperatures during cooling.	It could be a transitory situation. Switch the appliance off and on again and check for proper operation.
E01	Automatic address setting was not completed. The wirings between the indoor and outdoor units are cut or not properly connected.	Check the connection between the indoor and outdoor units.
E03	Error in receiving signals from the indoor unit.	
E04	Error in receiving signals from the indoor unit.	
E06	Communication problems between the ourdoor and indoor units.	
E07	Communication problems between the ourdoor and indoor units.	
E15	The power of the indoor unit is lower than that of the outdoor unit.	Check the sizes of the unit and have the indoor unit reconfigured.
E16	The power of the outdoor unit is lower than that of the indoor unit.	Check the sizes of the unit and have the indoor unit reconfigured.
E20	Automatic addressing procedure interrupted.	Check the connection between the indoor and outdoor units.
E31	Communication problems between the ourdoor and indoor units.	

10. TECHNICAL INFORMATION

10.1 Technical data

Indoor unit

Models	u.m.	15	30
Heating performance (A 7/6; A 20) (1)			
Nominal total capacity	kW	14,13	26,69
Minimum total capacity	kW	4,17	6,31
Maximum total capacity	kW	15,83	29,89
COP	(2)	3,88	3,74
COP (maximum - minimum)	(2)	5,53÷3,49	5,83÷3,36
Cooling performance (A 35; A 27/19) (3)			
Nominal total capacity	kW	14,01	24,18
Minimum total capacity	kW	4,11	6,12
Maximum total capacity	kW	16,58	26,53
EER	(2)	3,46	3,80
EER (maximum - minimum)	(2)	5,15÷2,62	5,31÷2,95
Airflow performance			
Nominal air flow rate	m ³ /h	2560	5010
Available pressure	Pa	170	170
Room side fan			
Type		Radial	
Number	No.	1	2
Maximum absorbed power	W	400	850
Sound levels			
Sound power radiated in the Lw channel	dB (A)	60,0	64,0
Average sound pressure at 3 m Lp	dB(A)	42,0	46,0
Electrical characteristics			
Power supply	V / ph / Hz	230 / 1 / 50	
Nominal absorbed power	kW	0,40	0,80
Total absorbed current	A	2,20	4,40
Protection rating	IP	X2	
Product dimensions			
Width	mm	1106	1458
Depth	mm	929	988
Height	mm	808	1041
Weight	kg	88,0	130,0
1. Outdoor air temperature: 7 °C b.s. and 6 °C b.u.; Indoor air temperature: 20 °C 2. EER and COP Classification according to EN14511 directive 3. Outdoor air temperature: 35 °C b.s.; Indoor air temperature: 27 °C b.s. and 19 °C b.u.			

Models	u.m.	15	30
Connections			
Air connections (Ø)	mm	355	355
Condensate drain connection	mm	30	30
1. Outdoor air temperature: 7 °C b.s. and 6 °C b.u.; Indoor air temperature: 20 °C 2. EER and COP Classification according to EN14511 directive 3. Outdoor air temperature: 35 °C b.s.; Indoor air temperature: 27 °C b.s. and 19 °C b.u.			

Outdoor unit

Models	u.m.	25	50
Heating airflow performance			
Maximum flow rate	m ³ /h	4980	8880
Cooling airflow performance			
Maximum flow rate	m ³ /h	5340	6960
Compressor			
Type		Rotary inverter	
Number	No.	1	1
Refrigerant type		R32	
Refrigerant quantity	kg	3,00	4,80
Heating sound levels			
Sound power transmitted to the Lw structure	dB (A)	76,0	82,0
Average sound pressure at 1 m Lp	dB(A)	56,0	63,0
Cooling sound levels			
Sound power transmitted to the Lw structure	dB (A)	76,0	76,0
Average sound pressure at 1 m Lp	dB(A)	56,0	57,0
Electrical characteristics			
Power supply	V / ph / Hz	400 / 3 / 50	
Maximum total absorbed power	W	7	12
Maximum total absorbed current	A	11,40	18,50
Protection rating	IP	X4	
Limits in heating			
Minimum outdoor air temperature	°C	-20,0	-20,0
Maximum outdoor air temperature	°C	24,0	24,0
Limits in cooling			
Minimum outdoor air temperature	°C	-15,0	-15,0
Maximum outdoor air temperature	°C	52,0	52,0
Product dimensions			
Width	mm	980	1140
Depth	mm	370	460
Height	mm	996	996
Weight	kg	84,0	109,0

Models	u.m.	25	50
Connections			
Liquid connection	"SAE	3/8	1/2
Gas connection	"SAE	5/8	7/8

10.2 Fuse Characteristics

Fuse	Rating (A)	Voltage (V)	Type	Characteristic Curve
F1	2	500	CH10	gG
F2	2	500	CH10	gG
F3	2	500	CH10	gG
F4	6	500	CH10	gG

10.3 Dimensions

Size 15

- A** Power supply
- B** Refrigerant connections
- C** Condensate drain

- D** Filter
- E** Electrical panel

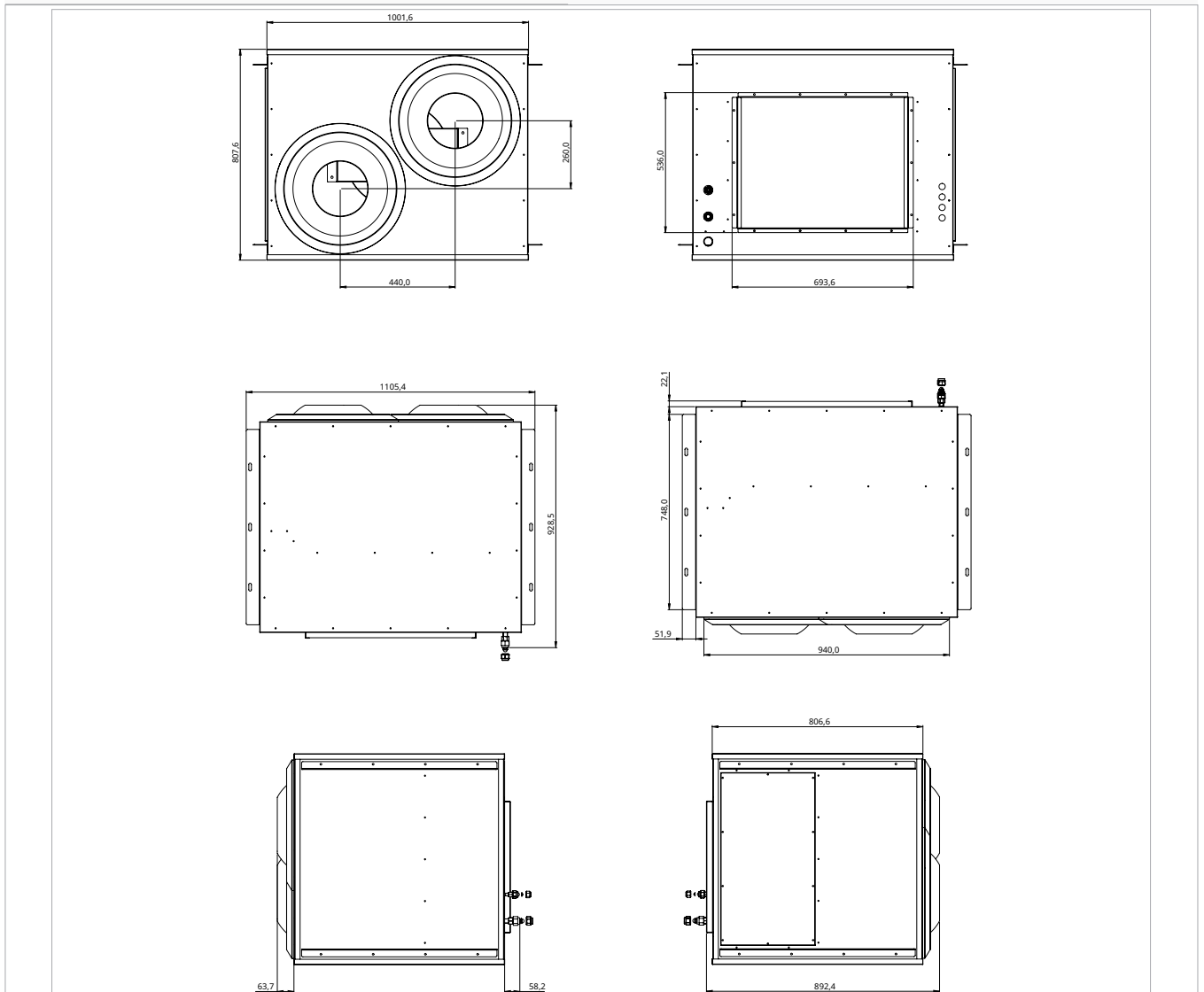

Size 30

- A** Power supply
- B** Refrigerant connections
- C** Condensate drain

- D** Filter
- E** Electrical panel

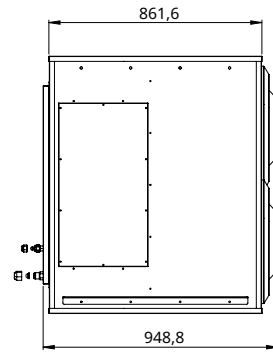
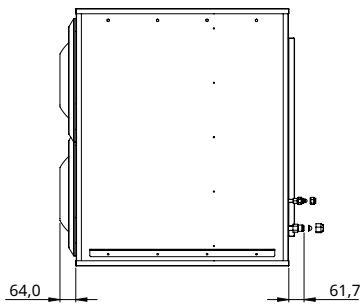
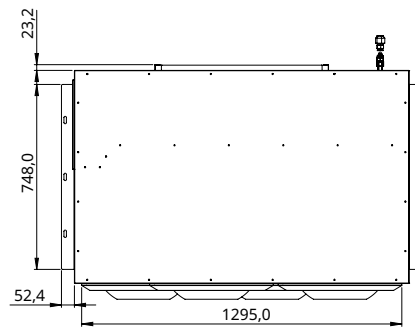
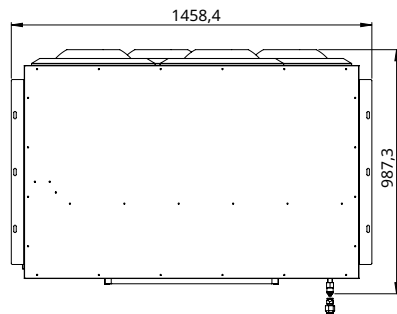
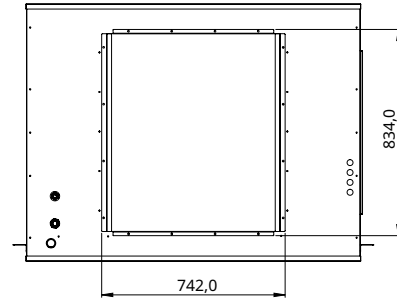
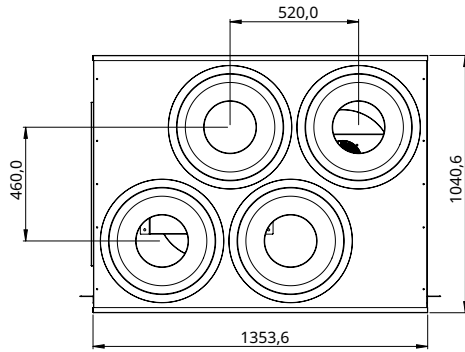

10.4 Indoor Unit Air Throws

Isothermal launching

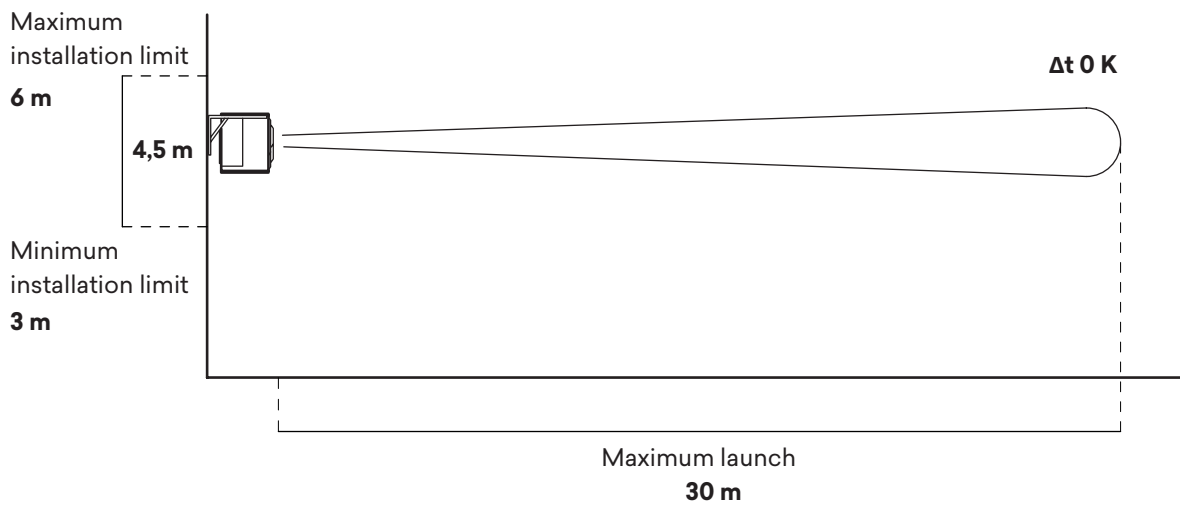

Warm-up launch

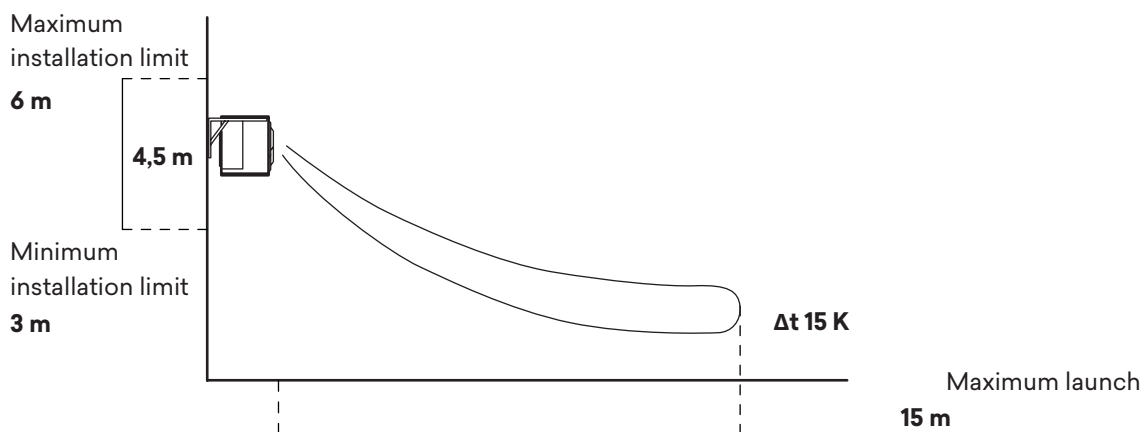

Cooling launch

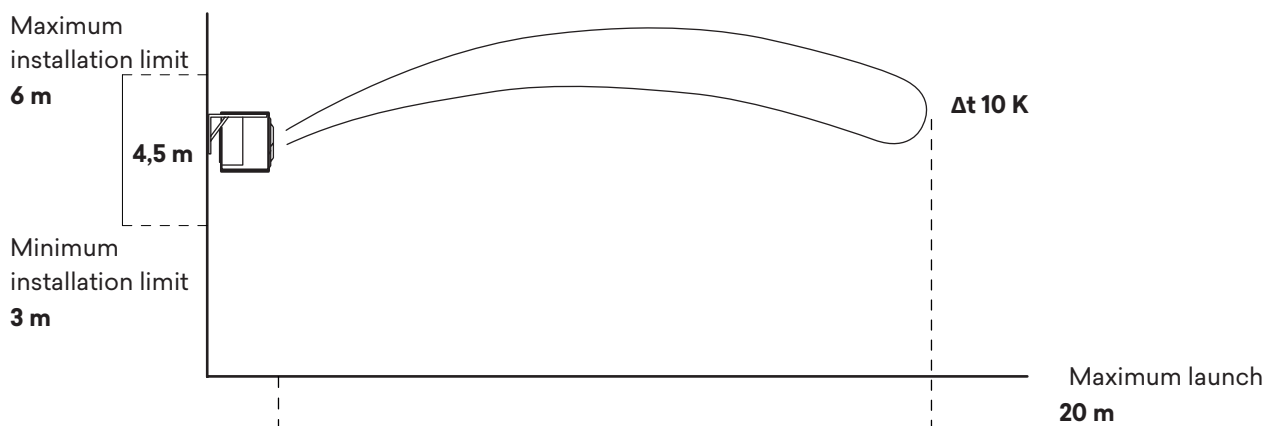



Getting In Touch

Powrmatic Limited
Hort Bridge, Ilminster
Somerset
TA19 9PS
tel: **+44 (0) 1460 53535**
fax: **+44 (0) 1460 52341**
e-mail: **info@powrmatic.co.uk**
web: **www.powrmatic.co.uk**



Powrmatic Ireland
45 Broomhill Close
Tallaght
Dublin 24
tel: **+353 (0) 1452 1533**
fax: **+353 (0) 1452 1764**
e-mail: **info@powrmatic.ie**
web: **www.powrmatic.ie**



Powrmatic pursues a policy of continuous improvement in both design and performance of its products and therefore reserves the right to change, amend or vary specifications without notice. Whilst the details contained herein are believed to be correct they do not form the basis of any contract and interested parties should contact the Company to confirm whether any material alterations have been made since publication of this brochure.