

POWRMATIC®

Delivering complete climate control solutions worldwide

Energy efficient infrared heating solutions dedicated to providing superior technology and superior performance.

In partnership with SRP.



Radiant Heaters

- Linear & U-Tube Forced & Vacuum Burner Heaters
- Combined Flue Herringbone Systems
- Radiant Plaque Heaters

Natural Gas & LPG Fired Options

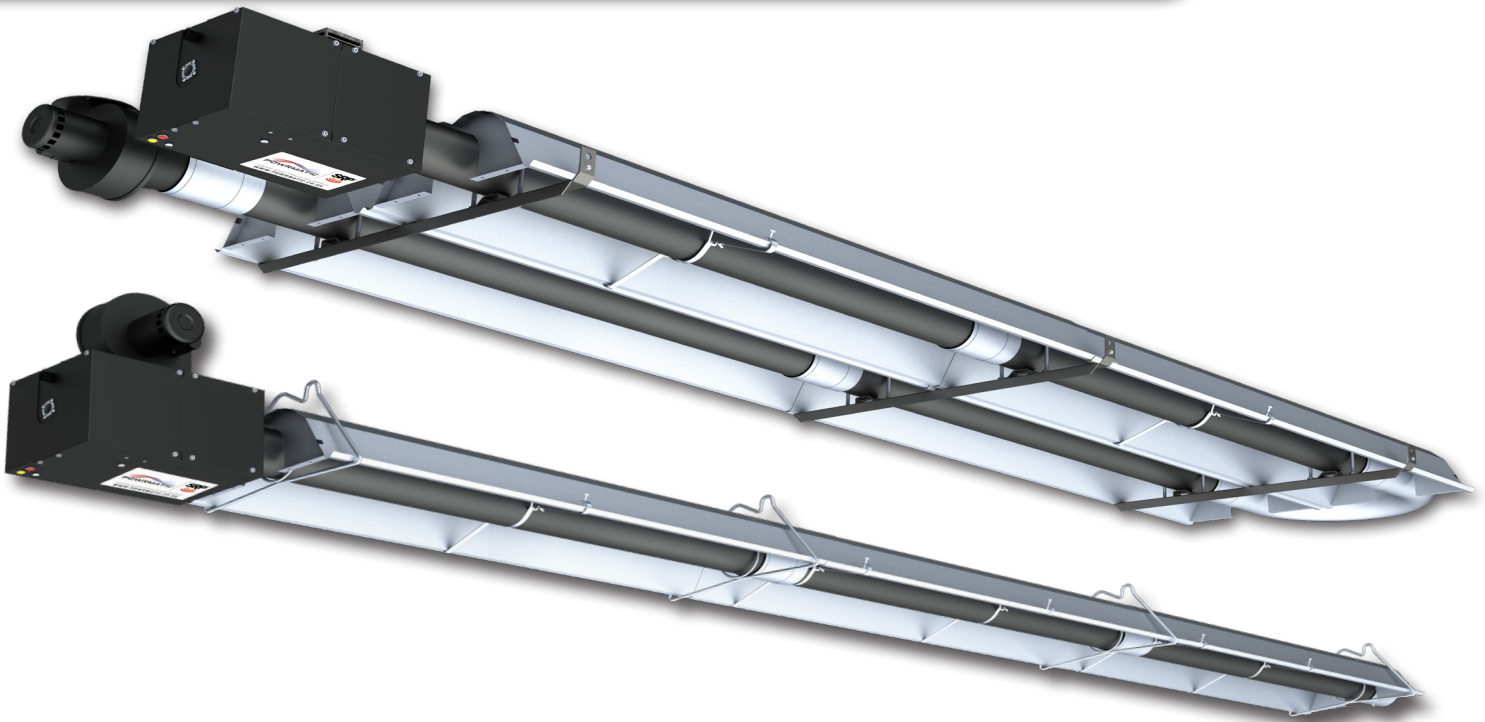

Radiant Heaters Linear & U-Tube Fo

ErP Compliance

From the 1st January 2018 all radiant heaters used to provide comfort for the occupants of a heated space are required to meet the minimum standards of 'seasonal' efficiency as determined by the Ecodesign regulation (EU) 2015/1188, Directive 2009/125/EC - Lot 20. Compliance to the standard is mandatory.

Radiant heaters placed on the market after 1st January 2018 comply with the requirements of the standard.



LOW NO_x
TECHNOLOGY

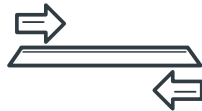

FORCED OR VACUUM
BURNER OPTION

100%

EFFICIENT REFLECTOR
PROFILE



U-TUBE OR LINEAR
CONFIGURATIONS



EFFECTIVE SPOT
HEATING SOLUTION

Efficient Instantaneous Compliant

Powrmatic Radiant Heater range
in partnership with SRP.

The range of Superior Radiant Products (SRP®) from Powrmatic feature optimal comfort and energy savings with two-stage technology. High/low capability allows for quicker recovery on the high fire and economical steady operation on the low fire with either U-Tube, Single and Double Linear configurations

The range comprises with outputs ranging from 10 to 60kW offering maximum efficiency from lightweight radiant heating tubes providing direct heat and warmth in a multitude of industrial, commercial and retail applications.

Models Available

- PL - Linear Forced Burners
- PU -U-Tube Forced Burners
- PVL - Linear Vacuum Burners
- PVU - U-Tube Vacuum Burners
- PVDL-Double Linear Vacuum Burners
- PVLHB-Linear Vacuum Herringbone Flued
- PVUHB - U-Tube Vacuum Herringbone Flued
- PSDE - Plaque Heaters

Product Features

Trusted Partnership

Superior Radiant Products (SRP®) is an industry leader in the design and manufacture of energy efficient infrared heating solutions and is dedicated to providing superior technology and superior performance.



Brackets & Suspension

Supported by heavy-duty galvanised hangars with single or double point suspension from the building structure. These rugged hangers are designed to carry the weight of the entire system and can be supported to direct the emitter at a 45 degree angle if needed.

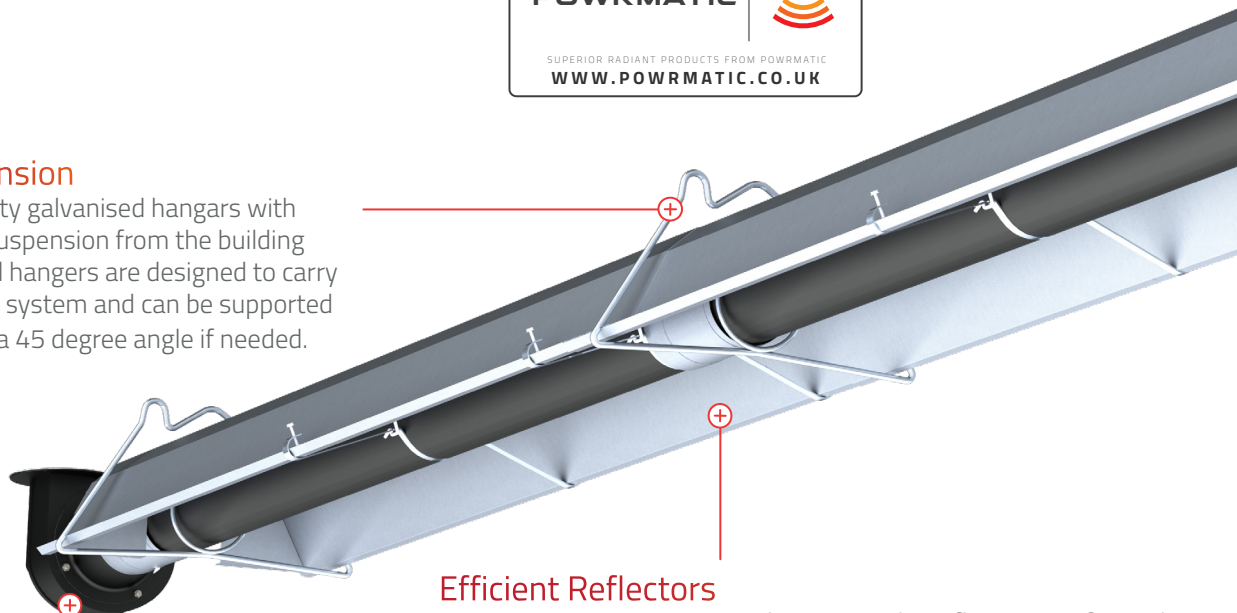

Induced Vacuum or Forced Burners

The range can be supplied with either induced vacuum burners or forced blown burners to provide different technically sound options. Unitary heaters may be installed with individual flues or combined to form a "Herringbone" type single flue system where site conditions dictate.

Efficient Reflectors

Using premium ASTM 1100 Aluminium, the reflectors are formed with a 100% efficient reflector profile designed to maximise the downward radiant heating effect and increase maximum efficiency. The reflector extends below the radiant tube ensuring maximum radiant energy is directed downwards.

Heat Treated Tube Design

Made with a heat treated aluminised calorised emitter tube surface - for flake free and cleaner working environment and little maintenance. The superior emissivity provides maximum radiant output whilst reducing emission levels.

High-Low Burner Technology

The range offers two stage high/low burners as standard. Automatic operation is ensured using the MC200 energy saving controllers with remote black-radiant sensors. Quick heat up and recovery is enhanced with additional fuel savings whilst excellent spot heated environmental comfort is guaranteed.

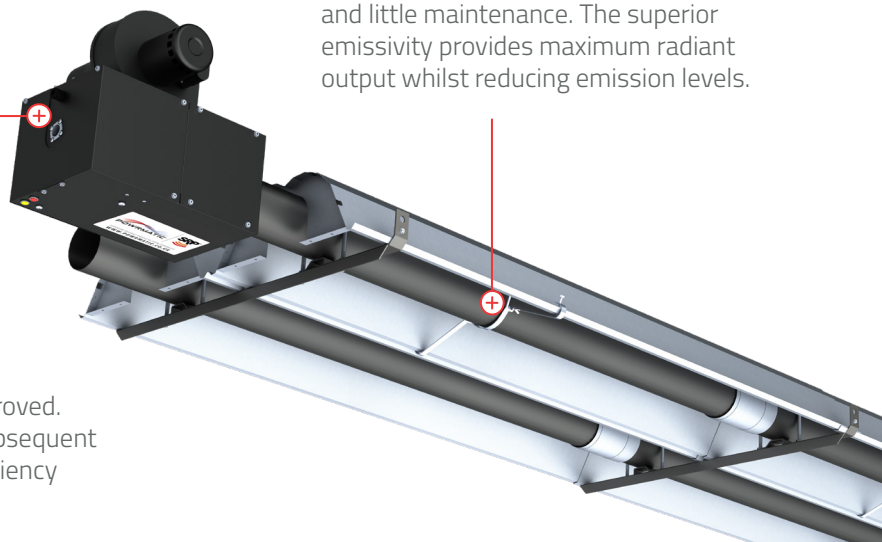

Approvals

 Radiant heaters are type tested and CE approved. In addition heaters placed on the market subsequent to 1st January 2018 meet the seasonal efficiency requirements of ErP Lot 20.

Technical Specification

PL & PU (Forced Linear & U-Tube)

Model			PL (Linear)							PU (U-Tube)				
			10	20LS	20	30	40	50	60	20US	20	30	40	50
Heat Input (Natural Gas)	High Fire	kW (gross)	11	22	22	30	43.5	52.5	61	22	22	30	43.5	52.5
	Low Fire	kW (gross)	8.5	17	17	23	32	40	44.5	17	17	23	32	40
Heat Input (Propane LPG)	High Fire	kW (gross)	10.5	21.5	21.5	29.5	40	N/A		21.5	21.5	29.5	40	N/A
	Low Fire	kW (gross)	8.5	16.5	16.5	23	31	N/A		16.5	16.5	23	31	N/A
NOx Seasonal (Gross)		mg/kWh	109	116	114	117	127	128	132	116	114	117	127	128
Seasonal Space Heating Energy Efficiency		% $\eta_{s,h}$	82.9	76.0	83.3	81.0	80.2	82.1	80.0	77.3	84.1	80.9	80.4	80.5
Gas Connection	BSP/Rc		1/2"				* 1/2"			1/2"				* 1/2"
Supply Pressure (nominal)	mbar		Nat Gas - 20 / Propane - 37							Nat Gas - 20 / Propane - 37				
Gas Consumption - High Fire (max)	m ³ /h	Nat Gas	1.06	2.11	2.11	2.85	4.12	5.02	5.82	2.11	2.11	2.85	4.12	5.02
		LPG	0.41	0.80	0.80	1.10	1.49	N/A		0.80	0.80	1.10	1.49	N/A
Gas Consumption - Low Fire (min)	m ³ /h	Nat Gas	0.85	1.64	1.64	2.22	3.07	3.81	4.23	1.64	1.64	2.17	3.07	3.81
		LPG	0.31	0.61	0.61	0.86	1.12	N/A		0.61	0.61	0.86	1.12	N/A
Electrics	V/ph/Hz		230/1/50							230/1/50				
Flue Diameter	mm		100							100				
Air Inlet Connection	mm		100							100				
Recommended Mounting Heights	m		2.5	3.0	3.0	4.0	5.0	5.5	6.5	3.0	3.0	4.0	5.0	5.5

Notes

- Fuel Consumption and output figures based upon nett calorific values as follows:
 - Natural Gas (G20) nett CV 34.02 MJ/m³
 - LPG Propane (G31) nett CV 88.00 MJ/m³ - Not available in 50/60kW
- Powrmatic radiant heaters have efficiency levels which comply with the requirements of United Kingdom Part L Building Regulations and the seasonal efficiency requirements of the Ecodesign regulation (EU) 2015/1188, Directive 2009/125/EC – Lot 20 (Known as ErP and mandatory as from 1st January 2018)
- Supra+ 100mm diameter flue is used on all SRP products. Fan to flue connectors are supplied as standard
- Ensure that the mounting height allows for a downward slop of 6mm in every 3m away from the burner
- *1/2" gas valve inlet - must be 3/4" gas flex

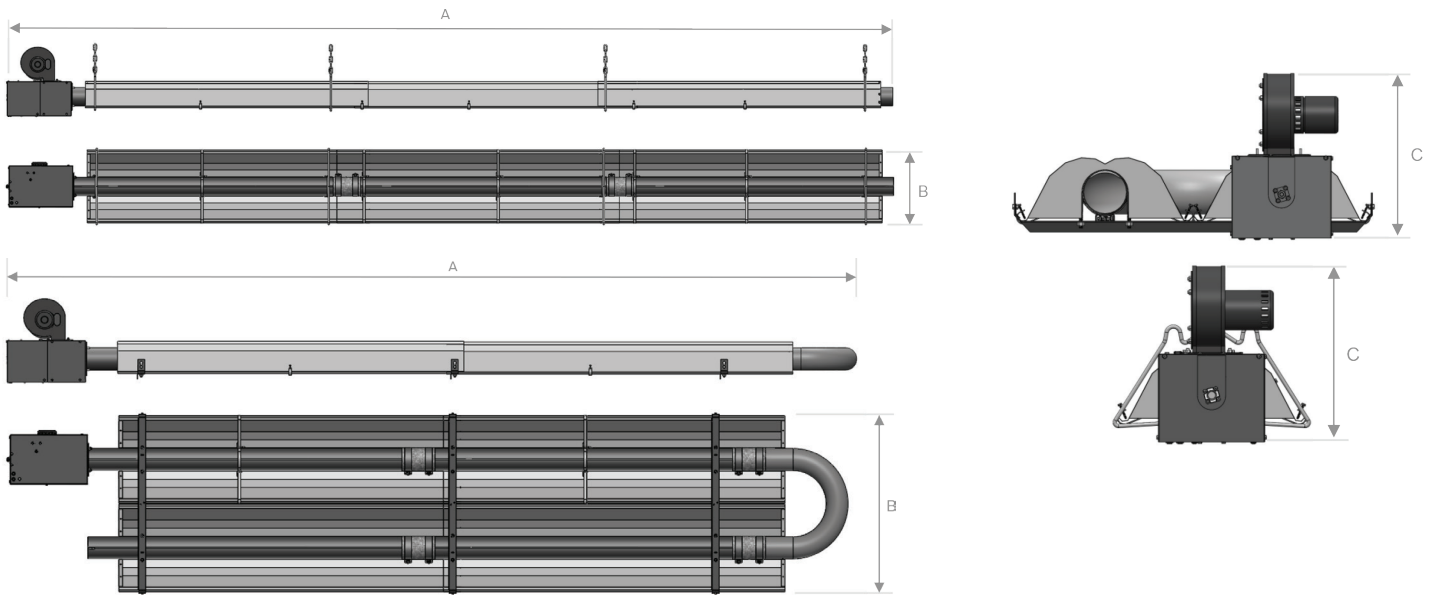

Dimensions & Weights

Model			PL (Linear)							PU (U-Tube)				
			10	20LS	20	30	40	50	60	20US	20	30	40	50
A	mm		3450	7975	9500	9500	12550	18650	21700	3875	5400	5400	6950	10000
B	mm		400	400	400	400	400	400	400	900	900	900	900	900
C	mm		400	400	400	400	400	400	400	390	390	390	390	390
Weight	kg		46	50	64	64	80	112	127	52	66	66	82	114

Technical Specification

PVL, PVU & PVDL (Vacuum Linear, U-Tube & Double Linear)

Model			PVL (Vacuum Linear)					PVU (Vacuum U-Tube)				
			20LS	20	30	40	50	20US	20	30	40	50
Heat Input (Natural Gas)	High Fire	kW (gross)	22	22	30.5	41	53	22	22	30.5	41	53
	Low Fire	kW (gross)	17.5	17.5	25	32.5	41	17.5	17.5	25	32.5	41
Heat Input (Propane LPG)	High Fire	kW (gross)	22	22	30	38	N/A	22	22	30	38	N/A
	Low Fire	kW (gross)	17	17	23.5	29.5	N/A	17	17	23.5	29.5	N/A
NOx Seasonal (Gross)		mg/kWh	125	123	121	118	113	125	128	121	118	113
Seasonal Space Heating Energy Efficiency		% $\eta_{s,h}$	75.9	84.1	80.4	81.1	82.0	76.0	82.6	82.0	80.5	80.0
Gas Connection		BSP/Rc	$\frac{1}{2}$ "			* $\frac{1}{2}$ "		$\frac{1}{2}$ "			* $\frac{1}{2}$ "	
Supply Pressure (nominal)		mbar	Nat Gas - 20 / Propane - 37					Nat Gas - 20 / Propane - 37				
Gas Consumption - High Fire (max)	m ³ /h	Nat Gas	2.11	2.11	2.91	3.91	5.02	2.11	2.11	2.91	3.91	5.02
		LPG	0.80	0.80	1.10	1.49	N/A	0.80	0.80	1.10	1.49	N/A
Gas Consumption - Low Fire (min)	m ³ /h	Nat Gas	1.64	1.64	2.38	3.07	3.91	1.64	1.64	2.38	3.07	3.91
		LPG	0.63	0.63	0.90	1.10	N/A	0.63	0.63	0.90	1.10	N/A
Electrics		V/ph/Hz	230/1/50					230/1/50				
Flue Diameter		mm	PVL - 100 / PVDL - 130					PVU - 100 / PVDU - 130				
Air Inlet Connection		mm	100					100				
Recommended Mounting Heights		m	3.0	3.0	4.0	5.0	5.5	3.0	3.0	4.0	5.0	5.5

For PVDL (Powrmatic Vacuum Double Linear) units the heat input and maximum gas flow rate are doubled)

Notes

- Fuel Consumption and output figures based upon nett calorific values as follows:
 - Natural Gas (G20) nett CV 34.02 MJ/m³
 - LPG Propane (G31) nett CV 88.00 MJ/m³ - Not available in 50kW
- Powrmatic radiant heaters have efficiency levels which comply with the requirements of United Kingdom Part L Building Regulations and the seasonal efficiency requirements of the Ecodesign regulation (EU) 2015/1188, Directive 2009/125/EC - Lot 20 (Known as ErP and mandatory as from 1st January 2018)
- Supra+ 100mm diameter flue is used on all SRP products. Fan to flue connectors are supplied as standard
- Ensure that the mounting height allows for a downward slop of 6mm in every 3m away from the burner
- *1/2" gas valve inlet - must be 3/4" gas flex

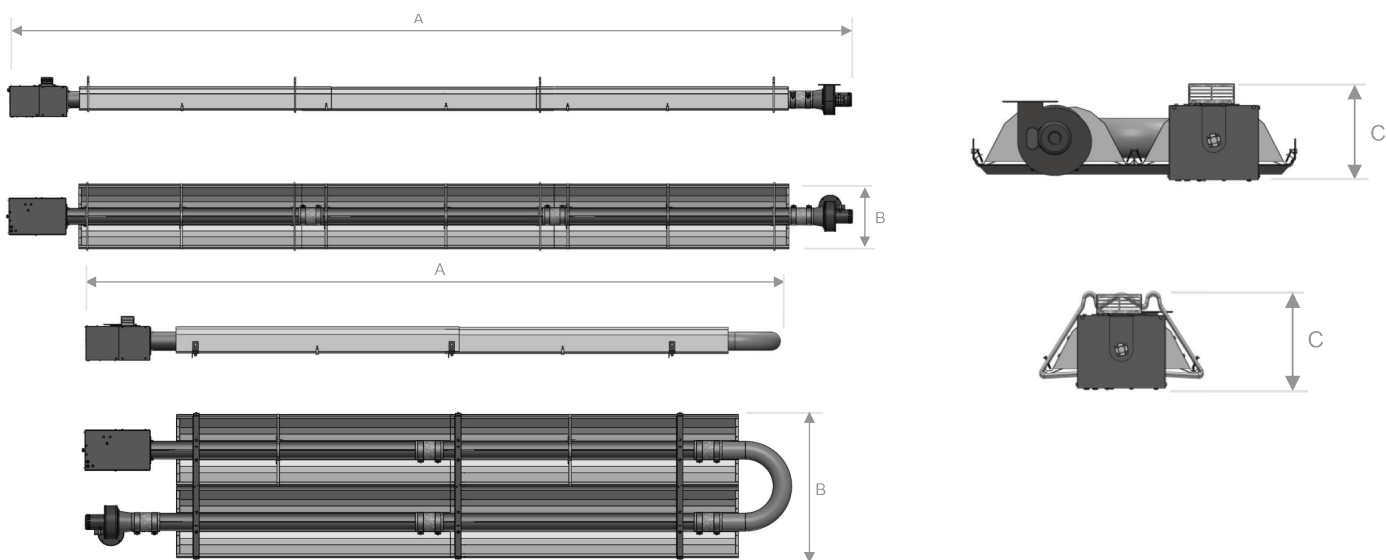

Dimensions & Weights

Model		PVL (Vacuum Linear)					PVU (Vacuum U-Tube)				
		20LS	20	30	40	50	20US	20	30	40	50
A	mm	7975	9850	9850	12900	19000	3875	5400	5400	6950	10000
B	mm	400	400	400	400	400	900	900	900	900	900
C	mm	250	250	250	250	250	250	250	250	250	250
Weight kg		55	66	64	80	112	52	66	66	82	114

For PVDL (Powrmatic Vacuum Double Linear) units dimension A and weights are doubled

Clearance To Combustibles

PL & PU (Forced Linear & U-Tube)

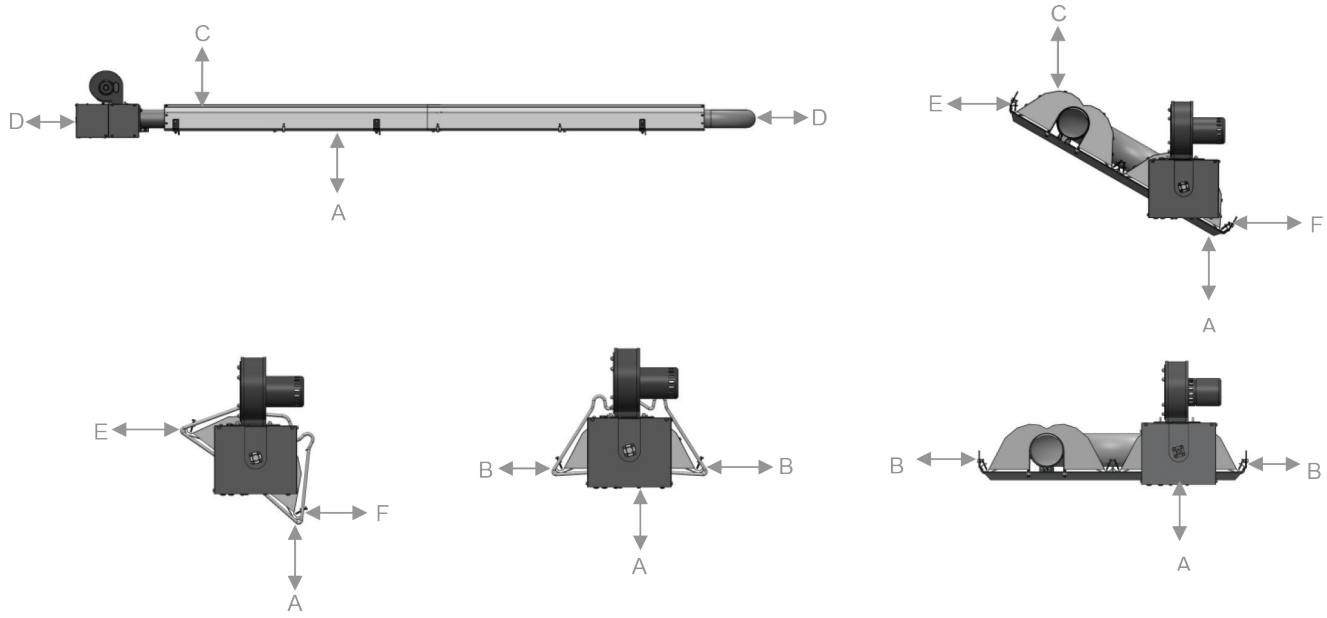

Model	Below	Side	Above Reflector	End	Front	Rear
	A (mm)	B (mm)	C (mm)	D (mm)	E (mm)	F (mm)
PL 10, 20LS, 20, 30, 40	1880	910	100	500	1630	100
PU 20US, 20, 30, 40	1930	940	100	500	1630	100
PL 50, 60	2030	1120	150	500	1830	100
PU 50	2080	1140	150	500	1830	100

- Notes:**
- The stated clearance to combustibles represents a surface temperature of 50°C above room temperature
 - It is the installer's responsibility to ensure that adjacent materials are protected from deterioration.

PVL, PVU, PVDL (Powmatic Vacuum Linear, U-Tube & Double Linear)

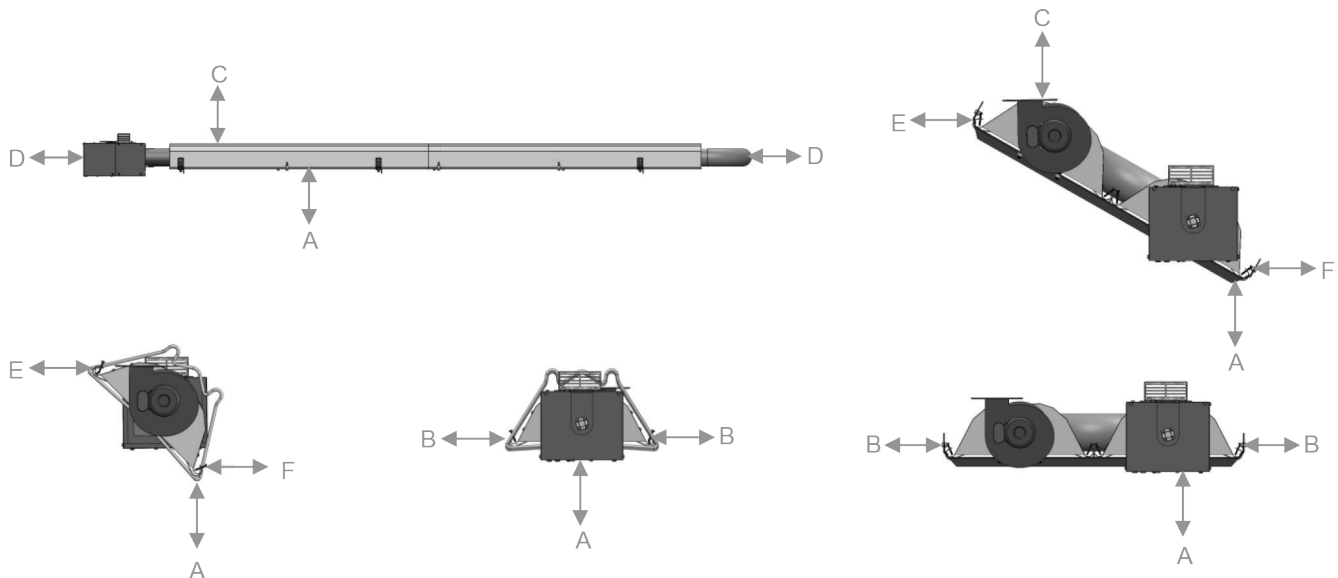

Model	Below	Side	Above Reflector	End	Front	Rear
	A (mm)	B (mm)	C (mm)	D (mm)	E (mm)	F (mm)
PVL 20LS, 20, 30, 40	1880	910	100	500	1630	100
PVU 20US, 20, 30, 40	1930	940	100	500	1630	100
PVL 50	2030	1120	150	500	1830	100
PV 50	2080	1140	150	500	1830	100

Combined Flue Herringbone Systems

PVL HB & PVU HB Linear/U-Tube Herringbone Flued Systems

Custom Combined Uniformity

Combined Herringbone Systems
From Powrmatic.

Providing installers and specifiers even greater flexibility, Powrmatic have introduced a combined exhaust manifold herringbone system to complement the range of Linear and U-Tube radiant heaters.

With up to 200kW capacity, the system can be designed to eliminate roof penetrations. Multiple individual heater exhausts will be combined in a single aluminium manifold system and flued through an outside wall or roof via a suitably sized vacuum exhaust fan.

Models Available

- PVL HB Linear Herringbone Flued
- PVU HB U-Tube Herringbone Flued

High/Low Burner Technology

The range offers two stage high/low burners as standard. Automatic operation is ensured using the MC200 energy saving controllers with remote black-radiant sensors. Quick heat up and recovery is enhanced with additional fuel savings whilst excellent spot heated environmental comfort is guaranteed.

Exhaust Fans

Vacuum exhaust fans are fitted for either 100 or 200kW input systems with a vertical or horizontal flue exit.

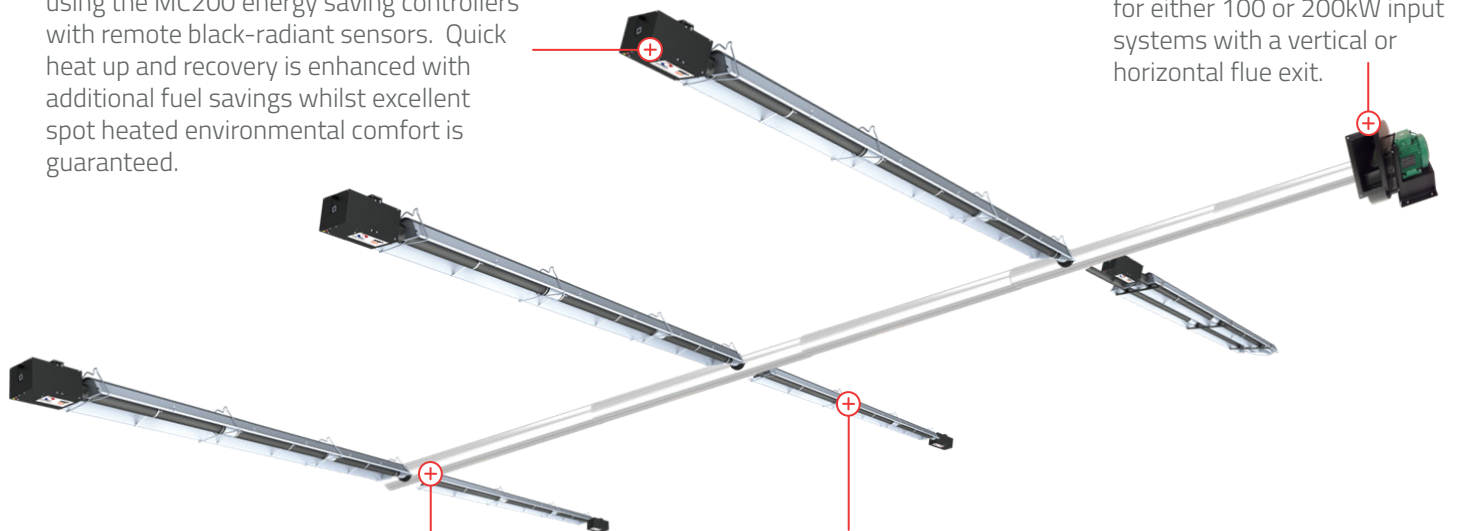

Superior Construction

The exhaust manifold and fittings are made from sturdy aluminium to ensure longevity and performance.

Optional Extras

Burner lockout indication, sports guards and side skirts are available on request.

Radiant Plaque Heaters

PSDE Range

Direct Robust Effective

Radiant Plaque Heaters
From Powrmatic

The PSDE range of high intensity gas fired radiant plaque heaters from Powrmatic provided efficient and directed, cost-effective heat for cold spots in industrial and commercial applications from 9-48Kw models available.

Automatic operation is ensured using the MC200 energy saving controllers with remote black-radiant sensors. Quick heat up and recovery is enhanced with additional fuel savings whilst excellent spot heated environmental comfort is guaranteed.

Construction

The entire construction is manufactured with rigid heavy duty construction non-corrosive aluminize steel.

Low Profile

The low profile design requires less space making it easier for installation and building positioning.

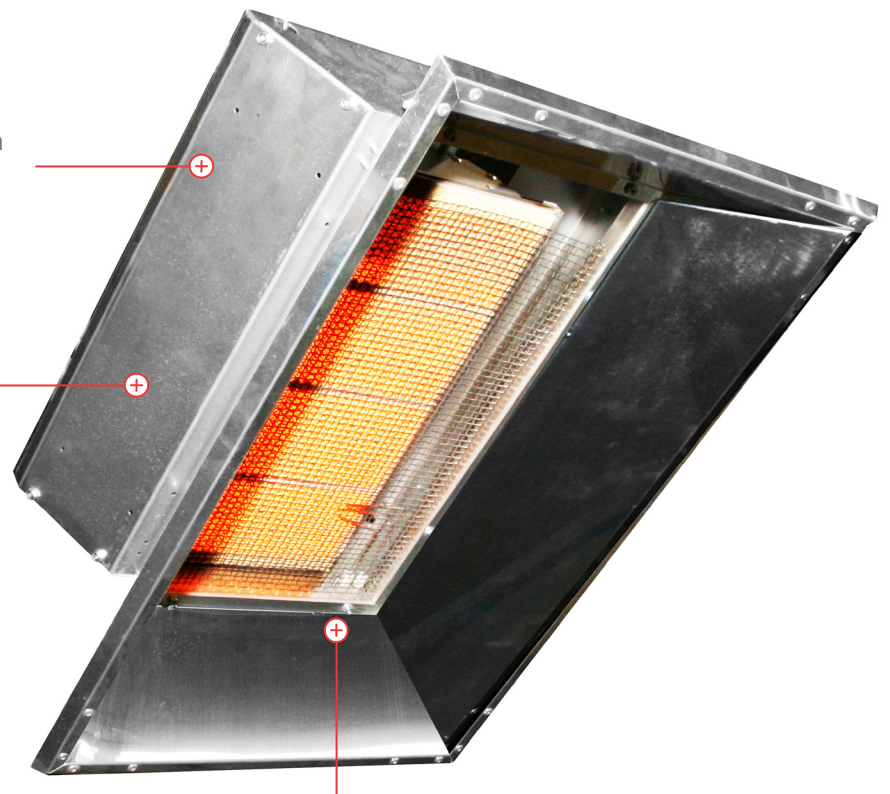

Reflector Technology

Maximized radiant efficiency with high-polished aluminum reflector.

Technical Specification

PSDE Range

Model			PSDE				
			10	20	30	40	45
Heat Input (Natural Gas)	High Fire	kW (gross)	10.5	20	31	41	45
Heat Input (Propane LPG)	High Fire	kW (gross)	9	17	26.5	33.5	N/A
Gas Connection	BSP/Rc		½"				
Supply Pressure	mbar		Nat Gas - 20 / Propane - 37				
Electrics	V/ph/Hz		230/1/50				
Radiating Surface Area	(mm)		5810	11610	17420	23230	23230
Injector Size	Natural Gas (mm)		2.44	2.44	2.44	2.44	2.58
	Propane (mm)		1.61	1.61	1.61	1.61	N/A
Burner Quality			1	2	3	4	4
Shipping Weight	(kg)		13.2	18.2	21.8	26.8	26.8

Dimensions

PSDE Range

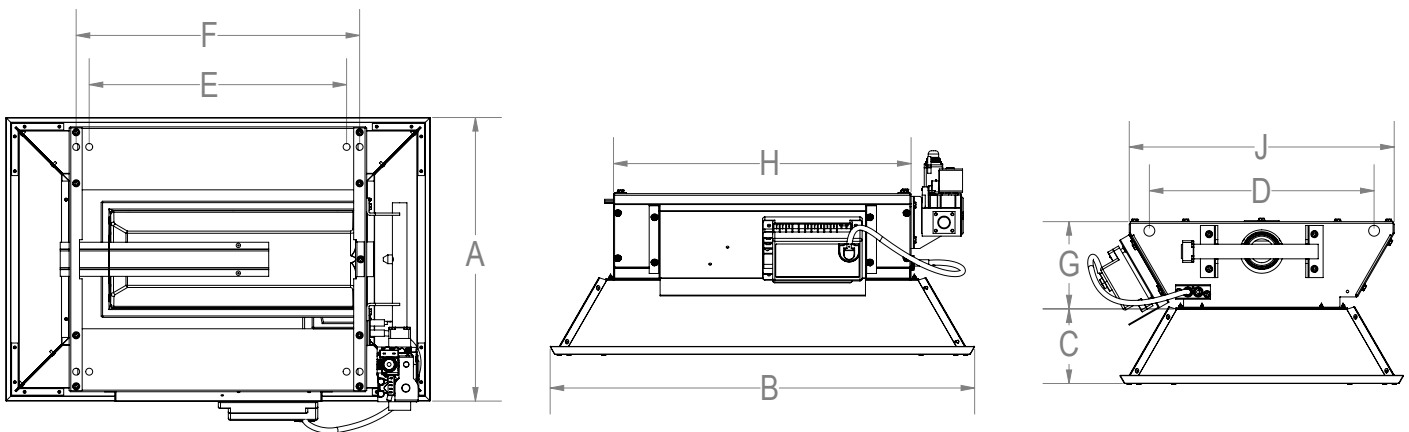

Model		PSDE				
		10	20	30	40	45
A	mm	414	587	762	937	937
B	mm	620	620	620	620	620
C	mm	107	107	107	107	107
D	mm	328	503	678	854	854
E	mm	376	376	376	376	376
F	mm	414	414	414	414	414
G	mm	127	127	127	127	127
H	mm	434	434	434	434	434
J	mm	386	561	737	912	912

Clearance To Combustibles

PSDE

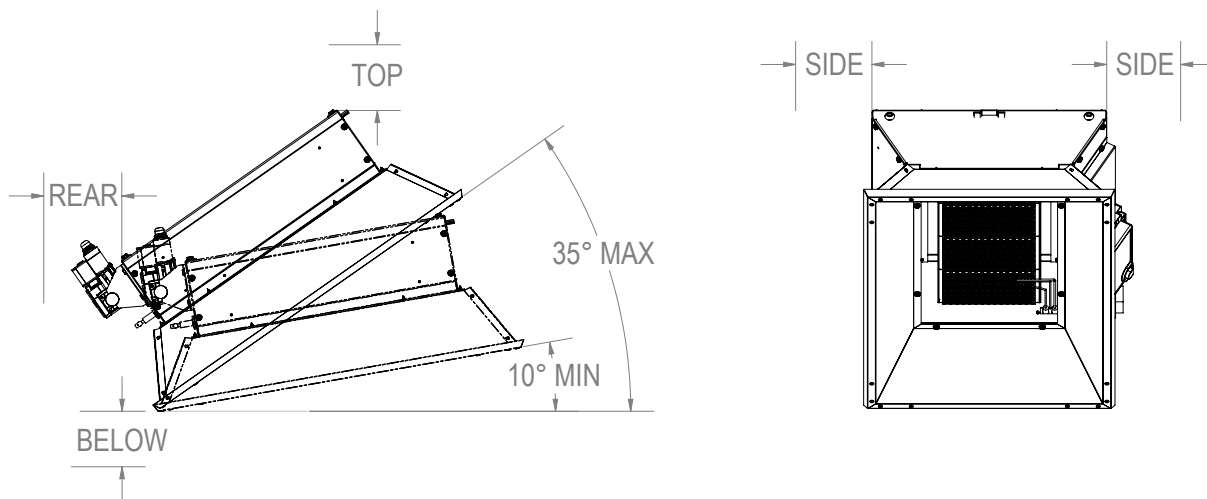

Model	Top	Sides	Rear	Below
	(mm)	(mm)	(mm)	(mm)
PSDE 10	890	710	510	1780
PSDE 20	1020	890	510	2030
PSDE 30	1270	1070	710	2540
PSDE 40	1370	1170	710	2800
PSDE 45	1530	1220	870	3410

Notes:

- Clearances as marked on the heater body must be maintained from vehicles parked beneath. Signs should be posted identifying any possible violation of the clearance distances from the heater in all vehicle areas.
- Maximum allowable stacking height in storage areas should be identified with signs or appropriate markings adjacent to the thermostat or in a conspicuous location.
- Clearance to combustibles DO NOT indicate acceptable distances from PVC paneling. Refer to panel manufacturers recommendations.
- Adequate clearance to sprinkler heads must be maintained
- The stated clearance to combustibles represents a surface temperature of 32°C above room temperature. It is the installer's responsibility to ensure that adjacent materials are protected from deterioration.

Your Installer Guide

All Radiant Products

General

The following notes are provided as a guide, however installers and operators should fully acquaint themselves with the more detailed guidance provided in the relevant installation manual. For copies of such manuals please consult our technical department or visit our website - www.powrmatic.co.uk

Standards

All Powrmatic radiant tube heaters are specifically designed for environmental space heating applications only and must be installed, commissioned and operated with due regard to appropriate regulations including, but not limited to, the Gas Safety (Installations and Use) Regulations 1998 for gas fired products, the Health and Safety at Works Act 1974, relevant Codes of Practice, BS-13410:2001 and other relevant standards, the possible requirements of Local Authorities, Fire Officers and insurers as well as Powrmatic's installation manual.

Position, Location & Assembly

Powrmatic radiant heaters are designed for internal location only. Effective heating is dependent upon mounting height as well as location within the building or heated zone. Minimum, as well as maximum, mounting heights must be observed.

Suspension materials must be non-combustible and of sufficient strength and integrity to support the weight loading. Heaters must be supported from permanent structures and on no account be supported from gas lines or other pipework. Heaters should be supported along the entire length using the appropriate mounting points provided. Linear heaters should have a 0.25° slope upwards towards the burner.

Consideration should also be given to flue routes and points of exit, gas, electrical and control connections, i.e. radiant heating characteristics of the heater, issues of public access and the siting of environmental control stations and/or remote temperature sensors where the position needs to be representative of the zone temperature to which they refer.

Heaters should not be installed in hazardous areas or areas where there is a foreseeable risk of flammable or corrosion inducing particles, gases or vapours being drawn into the combustion air circuit.

Effective and safe operation heaters is entirely dependent upon correct on-site assembly of the constituent parts. The assembly instructions provided must be strictly followed.

In all cases installers must refer to the Installation, Operation and Maintenance manual prior to commencing works.

Combustion Air, General Ventilation & Fluing

Within the United Kingdom mandatory regulations apply concerning the provision of combustion air and general heater ventilation. Powrmatic radiant tube heaters may be installed in either vented (flued) or unvented (unflued) mode however specific regulations and requirements apply for the safe evacuation of flue gases. Installers must refer to the Installation, Operation and Maintenance manual prior to commencing works.

Installation Clearances

Particular clearances are necessary for the correct and safe function of the heater as well as for maintenance purposes. Such clearances are confirmed in the relevant installation manual.

Pipework

Care should be taken when sizing gas pipework to ensure that minimum gas inlet pressures are not compromised under dynamic load conditions. Isolating valves and service unions should be provided for each heater and pipework installed with due regard for relevant standards and Codes of Practice.

The final connection to the heater must include a suitable flexible gas pipe so that the fixed element of gas pipework cannot be influenced or effected by expansion and movement of tube heater.

Guarantee

Powrmatic radiant tube heaters are provided with a comprehensive guarantee. For United Kingdom sales the heater has the benefit of a two year parts and one year labour guarantee. All guarantees are subject to terms and conditions.



PARTS WARRANTY



LABOUR WARRANTY

About Us

Powrmatic design, develop and deliver HVAC solutions worldwide across a wide range of commercial and industrial applications creating comfortable and safe environments, differentiated through innovation, integrity, compliance and service.

Our specialised HVAC divisions:

Heating

Industrial and commercial warm air and radiant space heating solutions manufactured to achieve efficient performance, compliance and reliability for every application in partnership with the HVAC trade.

Ventilation

Custom designed highly efficient, cost-effective smoke, natural and powered ventilators manufactured to meet project requirements of building operators, architects, specifiers and contractors.

Air Conditioning

Worldwide distributors of innovative wall mounted heat pumps air conditioner technology providing efficient comfort cooling and heating all year round.

Engineered Products

Bespoke heating and ventilation solutions designed to serve individual customers specific project requirements. In addition our OEM products provide partner AHU manufacturers with high quality energy efficient gas fired heat exchangers.

Contact Us

Powrmatic Limited
Hort Bridge, Ilminster
Somerset
TA19 9PS
tel: **+44 (0) 1460 53535**
fax: **+44 (0) 1460 52341**
e-mail: **info@powrmatic.co.uk**



Powrmatic Ireland
45 Broomhill Close
Tallaght
Dublin 24
tel: **+353 (0) 1452 1533**
fax: **+353 (0) 1452 1764**
e-mail: **info@powrmatic.ie**



#keepingthenationwarm



Powrmatic pursues a policy of continuous improvement in both design and performance of its products and therefore reserves the right to change, amend or vary specifications without notice. Whilst the details contained herein are believed to be correct they do not form the basis of any contract and interested parties should contact the Company to confirm whether any material alterations have been made since publication of this brochure.