

**POWRMATIC®**

# Vision H<sub>2</sub>O

Installation & Servicing Manual

Issue 1.4 Apr 2026





Dear Customer - thank you for choosing Powrmatic..

We appreciate you buying one of our high quality products and know that you have made the best choice. By choosing Powrmatic, you are investing in UK manufacturing & its workforce. We pride ourselves by manufacturing products that provide clean, comfortable and safe working environments worldwide together with the personal & professional service and back-up you deserve. If you have any questions or concerns regarding this product, please contact our Technical Support Team by calling 01460 53535.

This booklet consists of pages.

## Markings



## Compliance

This unit complies with the following European Directives:

- Low voltage 2014/35/EU
- Electro-magnetic compatibility 2014/30/EU
- Use restrictions of hazardous substances in electrical and electronic equipment 2011/65/EC (RoHS2)
- Waste electrical and electronic equipment 2012/19/EC (WEEE).

- Energy consumption indication on the labels of energy-related products 2010/30/EU
- ErP Directive 2009/125/EC and regulation 2012/20EC

 For declarations of conformity, certificates and other certification details please consult the website.

## Symbols

The pictograms in the next chapter provide the necessary information for correct, safe use of the appliance in a rapid,

unmistakable way.

## Editorial pictograms

 User  
- Refers to pages containing instructions or information for the user.

 Installer  
- Refers to pages containing instructions or information for the installer.

 Service  
- Refers to pages containing instructions or information for the CUSTOMER TECHNICAL ASSISTANCE SERVICE.

## Safety pictograms

 Warning  
- It indicates actions that require caution and a suitable preparation.

 Prohibition  
- Refers to prohibited actions.

# Contents

<b>1</b>	<b>General</b>	
1. 1	General warnings . . . . .	4
1. 2	Fundamental safety rules . . . . .	4
1. 3	Description . . . . .	5
1. 4	Storage . . . . .	5
1. 5	Handling . . . . .	6
1. 6	Shipping dimensions and weight . . . . .	6
1. 7	Supplied components . . . . .	6
1. 8	Unit parts . . . . .	7
<b>2</b>	<b>Installation</b>	
2. 1	Installation method . . . . .	8
2. 2	Choosing the position of the unit . . . . .	8
2. 3	Assembling the unit . . . . .	9
2. 4	Condensation drain preparation . . . . .	10
2. 5	Assembling air ducts and external shutters . . . . .	11
2. 6	Mounting the appliance on the bracket . . . . .	11
2. 7	Hydraulic and chemical characteristics of water . . . . .	13
2. 8	Electrical connection . . . . .	14
2. 9	High/low installation configuration . . . . .	16
2. 10	Setting cool only or heat only modes . . . . .	17
2. 11	Brightness regulation . . . . .	17
2. 12	Touch-screen display key lock . . . . .	17
2. 13	Hotel function . . . . .	17
2. 14	Detecting possible faults . . . . .	17
<b>3</b>	<b>Maintenance</b>	
3. 1	Periodic Maintenance . . . . .	19
3. 2	Troubleshooting . . . . .	20
3. 3	Technical specifications . . . . .	21

This booklet, code N420240A - Rev. 04 - (11/20) consists of 24 pages.

## GENERAL

### 1.1 General warnings

- ⚠ After unpacking, check that the contents are intact and that all parts are included. If not, contact the agent who sold the appliance to you.
- ⚠ The appliance must be installed by an authorised company. Once the work is done, it must issue a declaration of conformity to the client in compliance with current regulations and with the indications in the instruction manual supplied by the manufacturer with the appliance.
- ⚠ These appliances have been designed for conditioning and/or heating rooms and they must be destined solely for this purpose, in accordance with their performance characteristics.  
The manufacturer refuses any contractual or extra-contractual liability for damage caused to people, animals or property resulting from incorrect installation, adjustment, maintenance or improper use.
- ⚠ In the event of water leaks, turn off the main switch and close the water taps.  
Immediately call the Technical Assistance Service or other qualified personnel and do not intervene personally on the appliance.
- ⚠ A temperature that is too high or too low is harmful to health and is an unnecessary waste of energy.  
Avoid prolonged direct contact with the air flow.
- ⚠ Do not leave the room closed for long. Periodically open the windows to ensure proper ventilation.
- ⚠ This instruction booklet is an integral part of the appliance and, therefore, it must be kept with care and must ALWAYS accompany the appliance, even when the latter is transferred to another owner or user or transferred to another system. If it gets damaged or lost, please request another copy from the local Technical Assistance Service.
- ⚠ Repairs or maintenance must be performed by the Technical Assistance Service or by qualified personnel in accordance with this manual. Do not modify or tamper with the appliance as this could create dangerous situations and the manufacturer will not be liable for any damage caused.
- ⚠ The appliance is declared to have an IPX0 protection rating, therefore, it cannot be installed outdoors or in laundry rooms.

### 1.2 Fundamental safety rules

- ⊖ The use of products that use electricity and water requires the observation of some fundamental safety rules such as:
  - ⊖ The unit can be used by children over the age of 8, and by people with reduced physical, sensory or mental capabilities, or with no experience or necessary knowledge, as long as they are monitored or after they have received instructions on the safe use of the unit and have understood the dangers involved.  
Children must not play with the appliance.  
The cleaning and maintenance that must be performed by the user should not be carried out by children without supervision.
  - ⊖ It is forbidden to modify the safety or adjustment devices without authorisation from and indications of the manufacturer.
  - ⊖ It is forbidden to pull, remove or twist the electric cables coming out of the unit, even when disconnected from the mains power supply.
  - ⊖ It is forbidden to introduce objects or substances through the aspiration grills and the air outflow.
  - ⊖ It is forbidden to open the access doors to the internal parts of the appliance without having turned off the main switch first.
  - ⊖ It is forbidden to dispose of, or leave in the reach of children, the packaging materials which could become a source of danger.
  - ⊖ It is forbidden to climb onto the appliance and/or to place any type of object on top of it.

# General

## 1.3 Description

The Vision air conditioning unit is the new solution that represents a significant step towards reducing the aesthetic impact of air conditioners. With a depth of just 16 centimetres, Vision is the most compact and least bulky of the category. Its aesthetic impact is therefore minimal, both inside and out.

### Optimised Capacities

The conditioning capacities of Vision have been optimised so as to obtain the right temperature for the best level of comfort and, therefore, less consumption and less noise. Thanks to the careful choice of sound insulation materials, the noise is similar to that of a standard wall split unit and consumption is drastically contained thanks to the new direct current fan.

### BLDC inverter technology

We have perfected the inverter technology to offer the best in terms of acoustic comfort (noise) and performance: reduction of consumptions, maintenance of the best temperature level and humidity level in the room.

Thanks to the use of the cutting edge BLDC (brushless direct current) inverter regulation, vibrations have been completely eliminated and acoustic emissions have been lowered to exceptional levels.

Both ventilation motors are BLDC to reduce consumption still further and make flow adjustment more precise.

The energy consumption is extremely low thanks to the absorption values which, in the case of partial load, fall to less than 300 W. At the nominal cooling power Vision, in the DC Inverter versions, it has a 3.9 EER, in the vanguard in the sector of fixed-unit monobloc air conditioners.

### Easy to install

Vision can be installed on any perimeter wall either low or high. Everything needed for installation (template, support bracket, hole pipes and external grids), excluding the drill and drill bit, is included in the box.

### Remote control and on-board touch-screen display

In addition to the remote control, the touch-screen display on the unit enables the setting of any function. There's even a "lock" mode to avoid any improper use. With a simple action on the touch screen display, the "heating" function can be deactivated: the appliance will then operate in "cooling" only, without the need for the condensate discharge pipe. The orientation of the air flaps, upwards or downwards, can also be set by simply pressing a key.

## 1.4 Storage

The packing is made of suitable material and carried out by expert personnel. All units are checked and tested and are delivered complete and in perfect conditions, however please perform the following instructions to check the quality of shipping services:

- upon receipt, check if the box is damaged. If that is the case, accept the goods with reservations and keep photographic evidence of any damage found
- unpack and check the contents against the packing list.
- check that none of the parts have been damaged during shipment. In case of damage, report it to the shipping company within 3 days of receipt by

registered letter with return receipt and attaching photographic documentation. A copy should also be sent by fax to the MANUFACTURER. No notice of damage incurred will be accepted after 3 days from delivery.

-  Keep the packing at least for the duration of the warranty period, in case you need to ship the air-conditioner to the service centre for repair. Dispose of the packing materials in compliance with current regulations on waste disposal.

Store the box in a closed environment protected from atmospheric agents and isolate it from the floor using planks or pallets.

-  Do not turn the carton upside down

## 1.5 Handling

The unit is packed singularly in a cardboard box. Boxes can either be carried singularly by hand by two operators or loaded on a forklift truck, for a maximum of three units.

⚠ Handling must be performed by qualified personnel, with specific tools and with equipment suitable for the weight of the appliance.

⚠ The appliance is unbalanced on the right (compressor side)

⚠ During transportation, the appliance must be kept in vertical position.

## 1.6 Shipping dimensions and weight

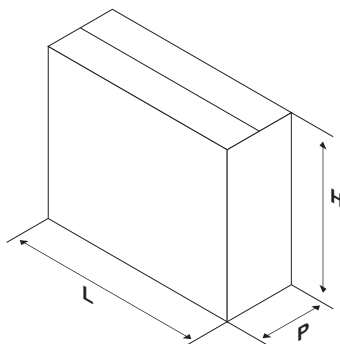

Packaging	M.E.	Vision 3.1 H2O
<b>Dimensions</b>		
Weight	kg	47,6
L	mm	1.100
H	mm	660
P	mm	260

## 1.7 Supplied components

The supply consists of the parts listed in the following table. Before assembly, please check that they are all at hand.

<b>A</b>	Screws and plugs kit (6 pcs)
<b>B</b>	Bracket for wall mounting
<b>C</b>	User manual
<b>D</b>	Remote control

<b>E</b>	Paper template for holes
<b>F</b>	CR2025 3V remote control battery
<b>N</b>	Installation manual

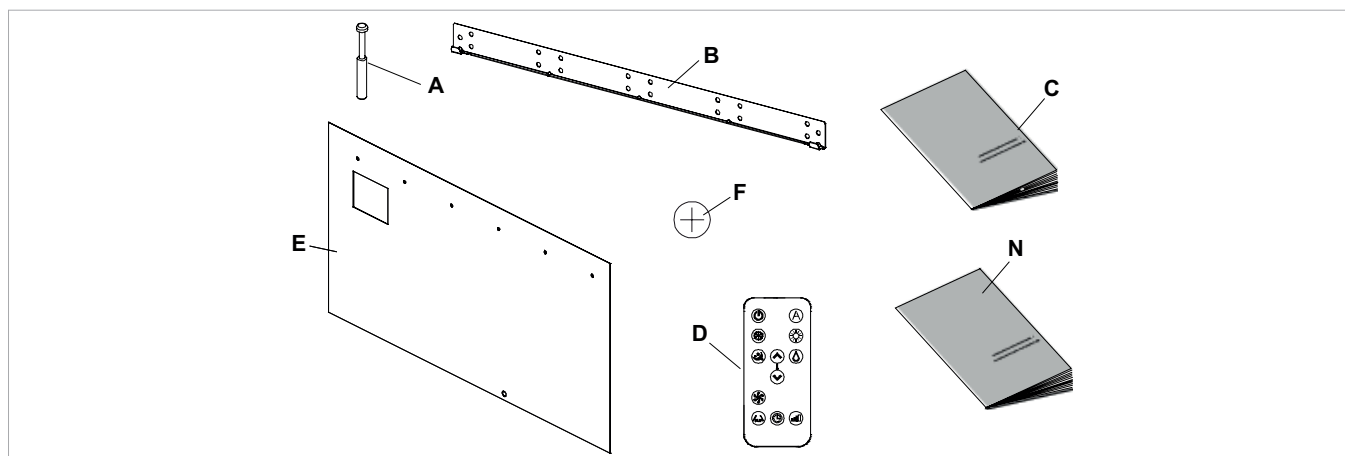

# General

## 1.8 Unit parts

1	Air outlet flaps
2	Touch screen display
3	Front panel
4	Water entrance (Eurokonus M3/4")
5	Outlet water (Euokonus M3/4")
6	Internal air intake grille

7	Air Filter
8	Anti-lifting bracket
9	Room air probe
10	Power supply terminal block
11	Decorative side panel
12	Modulating valve kit

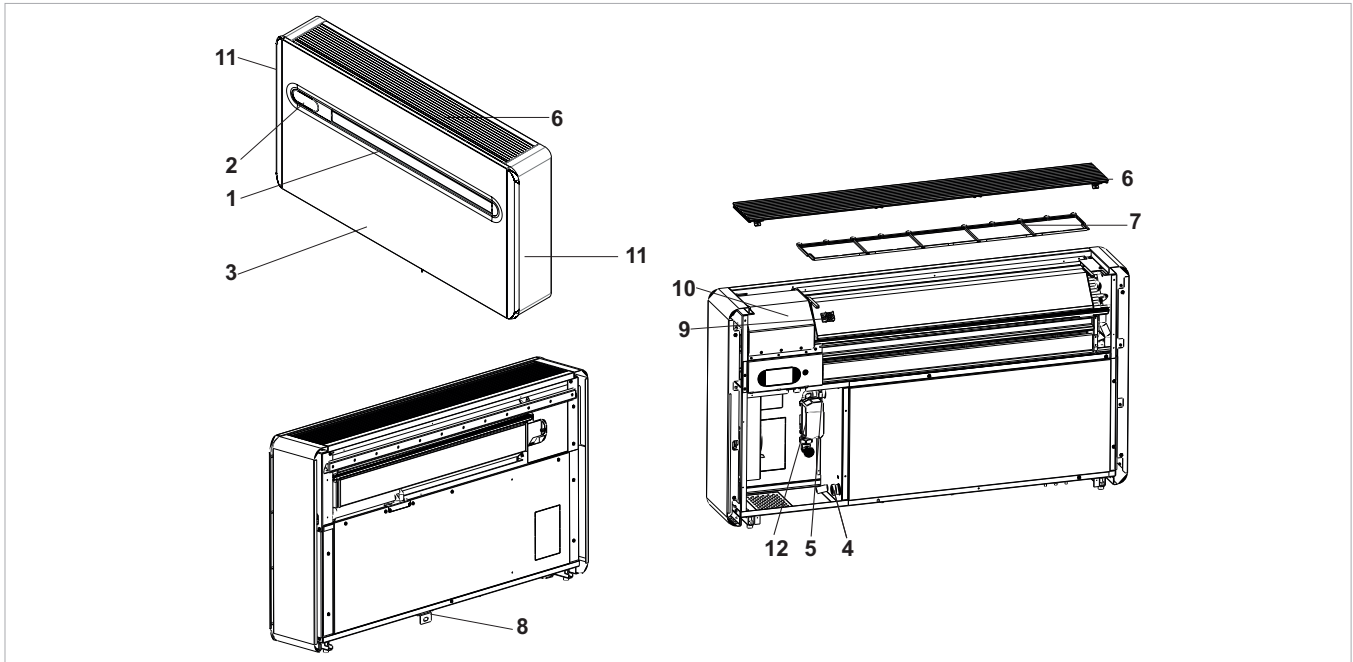

## INSTALLATION

### 2.1 Installation method

Before installing the conditioner, it is essential to calculate the summer thermal loads (and winter ones for the models with a heat pump) of the room. The more exact the calculation, the better the product will work. Please refer to current regulations to carry out calculations. For large-scale installations, please call a specialised heat engineer firm. Therefore, try to reduce higher heat loads by following instructions below:

- Cover large windows exposed to sunlight with curtains or with external maskings (blinds, porches, reflecting films, etc.).
- The room must remain closed for as long as possible.
- Avoid turning on halogen lamps or other high energy consumption appliances such as small ovens, steam irons, hot plates etc.).

### 2.2 Choosing the position of the unit

For the best performance of the appliance and to avoid malfunctions or dangerous situations, the location of the unit must meet the following requisites:

- Respect the minimum distances indicated in the diagram.
- The wall on which you intend to anchor the unit must be robust and able to support its weight.
- Leave enough space around the unit to perform maintenance operations.
- Nothing must obstruct the air flow both in the top suction part (curtains, plants, furniture) and in the lower outlet part, as it could cause vibrations which might prevent the appliance from working correctly

- ⚠ The appliance is stated as having an IPX0 protection rating, therefore it is not suitable for outdoor installation.
- ⚠ Check that there are no structures or systems (beams, pillars, hydraulic pipes, electrical cables etc.) in the part that must be drilled.
- ⚠ Never force the air flap open;
- ⚠ The appliance must not be installed directly above another electrical appliance (TV, radio, fridge, etc.) or above a source of heat.

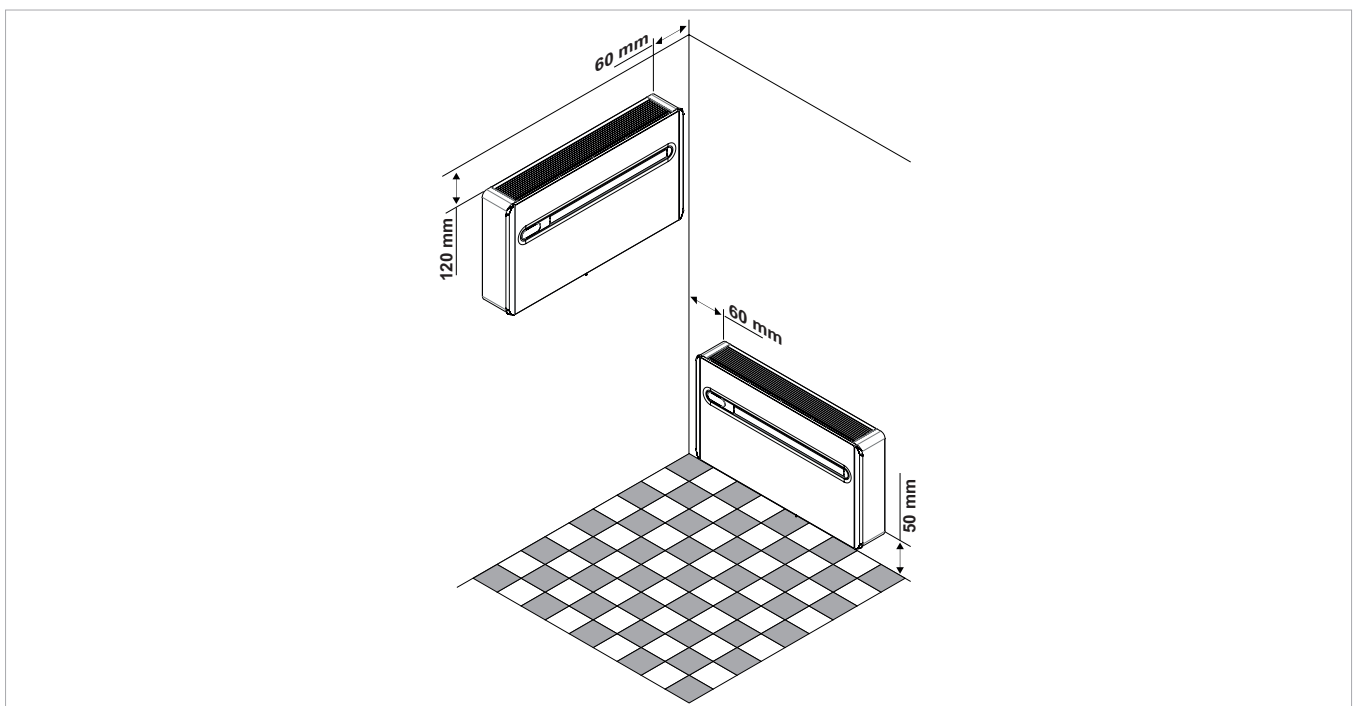

# Installation

## 2.3 Assembling the unit

To install the unit on a wall, drill 6 holes to attach the fixing plate to the wall as indicated on the drilling template. The appliance weighs more on the right, so make sure to secure it properly on this side. The holes must have an 8 mm diameter to accommodate the 6 supplied plugs.

A thorough examination of the characteristics and consistency of the wall must always be carried out to determine the number of fixing points to be made and to choose specific plugs in particular conditions. In the case of installation on a plasterboard or on walls with low density, place a bracket, if necessary on the outside, that can support the appliance safely.

**⚠** The manufacturer cannot be held responsible for any underestimation of the structural consistency of the anchoring carried out by the installer. We, therefore, encourage you to pay the utmost attention to this operation as, if performed badly, it could cause serious damage to people and objects.

**⚠** Drill a hole in the position indicated on the template for those heat-pump appliances without a condensation drain built in the wall to allow for draining of condensation.

**⚠** A hole is also indicated on the template to secure the appliance on the wall with an anti-lifting bracket, which is already on the appliance.

<b>A</b>	Holes for M8 plugs
<b>B</b>	Electrical connection area
<b>C</b>	
<b>D</b>	
<b>E</b>	Anti-lifting bracket hole

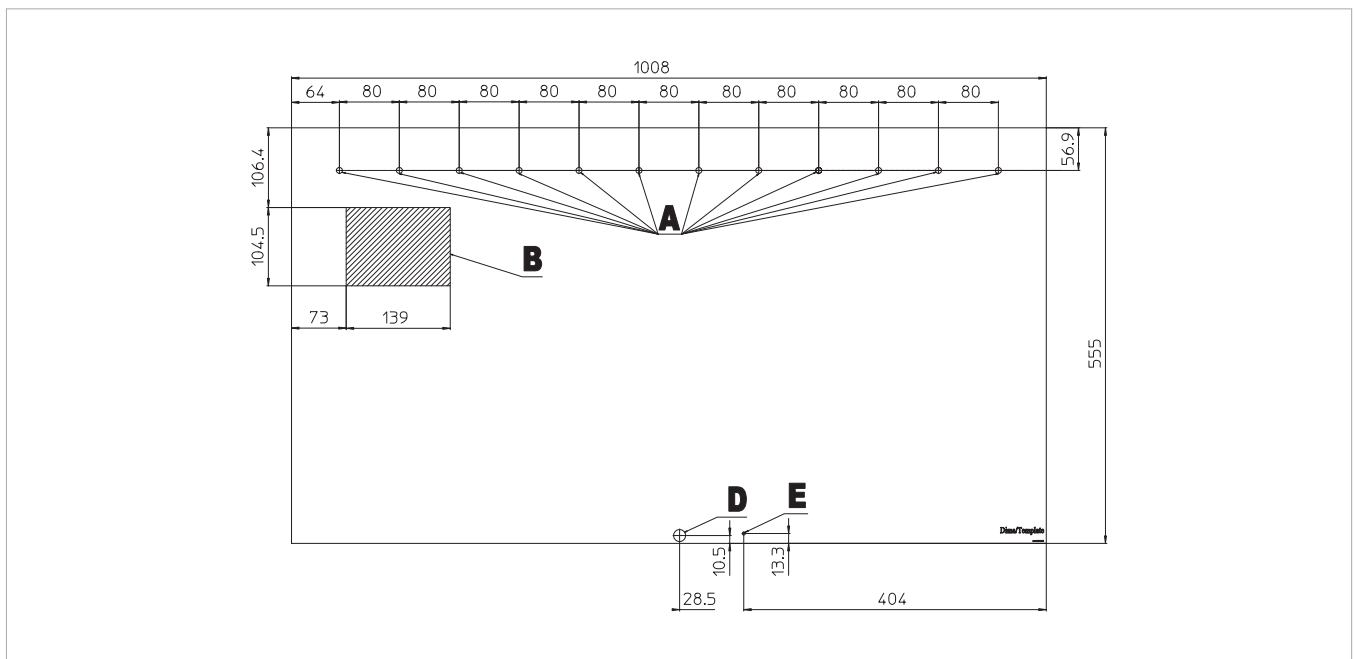

## 2.4 Condensation drain preparation

For heat pump appliances, a condensation drain pipe (internal Ø16 mm, not supplied) must connect the unit to the pipe on the rear of the appliance.

A solenoid valve will start the flow of the condensation from the internal collection tray when the maximum level has been reached. For cooling only appliances, this pipe must be connected if the appliance is intended for use with low external temperatures (below 23°C). Drainage occurs by gravity. For this reason, it is essential for the discharge pipe to have at least a 3% minimum slope in every point. The pipe to be used can be rigid or flexible with a minimum inner diameter of 16 mm. If the line flows into a sewer system, it is necessary to add a siphon before placing the pipe into the main drain. This siphon must be placed at least 300 mm under the mouth of the appliance.

**⚠** If the line flows into a container (e.g. a tank), do not close the container hermetically and avoid immersing the draining pipe into the water.

- ⚠** The hole for the condensation pipe must always slope towards the outside.
- ⚠** The exact position in which to place the pipe mouth is indicated on the template.
- ⚠** Check that the expelled water does not cause any damage or problems to people or objects. During winter, this water may create sheets of ice outside.
- ⚠** When connecting the condensation drain, be careful not to squeeze the rubber duct.
- ⚠** It is possible to empty the collection tray using the safety drain at the base of the appliance if necessary.

### 1 Safety drain to empty tray

### 2 Condensation drain duct

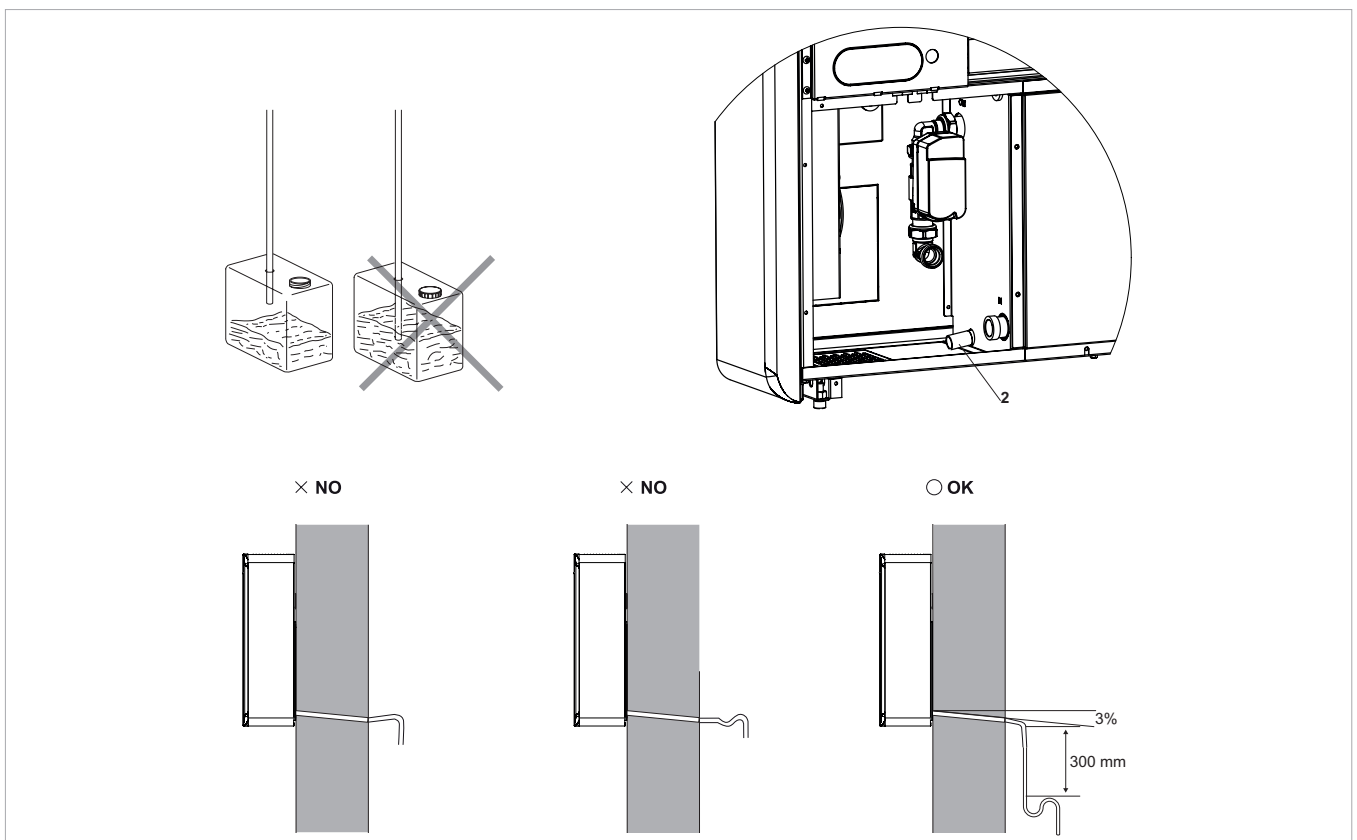

# Installation

## 2.5 Mounting the appliance on the bracket

After checking that the bracket is anchored to the wall and that all necessary electrical connections and condensation drain preparations have been made, you can mount the conditioner. Lift it by the sides of the bottom base until the bracket fits on all of the right spots on the appliance. In order to ease the operation, slightly tilt the appliance towards you.

Direct electrical connections (disconnecting the power supply cable) and the anchoring of the condensation drain must be carried out after having spaced the appliance from the wall using a wooden wedge or any other similar

object.

Once the work is done, check that there are no openings on the back of the appliance, especially where the air ducts are connected. To improve installation safety, the machine can be secured to the wall with a dedicated anti-lifting bracket

which is located on the rear part of the machine. The drilling position is indicated on the installation template.

1	Bracket
2	Bracket anchoring points

3	Anti-lifting bracket
---	----------------------

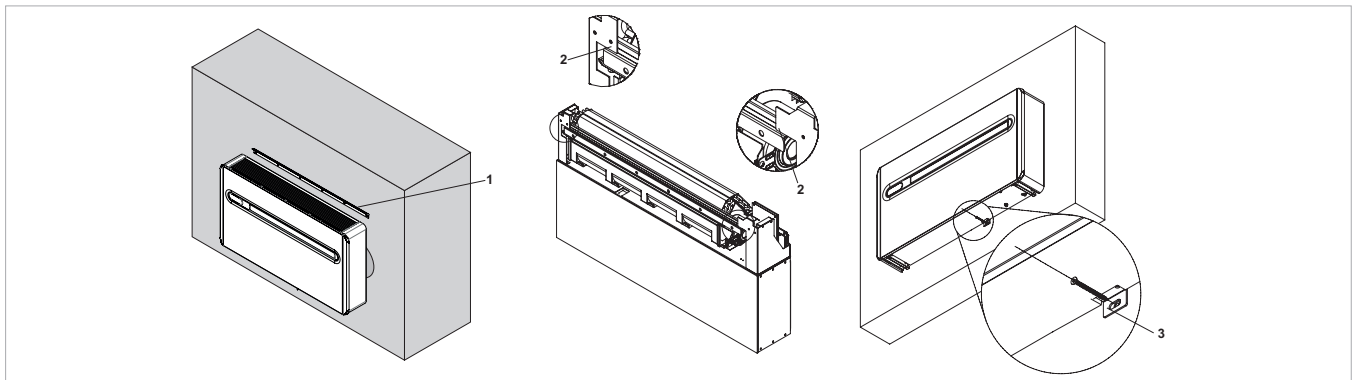

## 2.6 Hydraulic connection

The unit to work requires water connection to an open or closed water circuit.

The choice and installation of the components is entrusted, by competence, to the installer who will operate according to the rules of good technique and current legislation. Before connecting the piping make sure that these do not contain stones, sand, rust, slag or in any case foreign bodies that could damage the system.

It is advisable to create a by-pass in the system in order to flush the exchanger without having to disconnect the appliance. The connecting pipes must be supported so as not to burden the appliance with their weight.

The hydraulic connections must be completed by installing:

- air vent valves at the highest points of the piping;
- flexible joints;
- shut-off valves.

The hydraulic connections are located in the lower part on the left and must be arranged in such a way that they are hidden by the air conditioner casing.

**⚠** The minimum nominal diameter of the connecting pipes must be 1/2".

To allow the maintenance or repair operations it is essential that each hydraulic connection is equipped with the relative manual closing valves.

The water connection pipes must be suitably insulated by virtue of the supply temperature.

To avoid air pockets inside the circuit we strongly recommend to put automatic or manual venting devices at all points (higher pipes, siphons, etc.) where the air can accumulate.

If the mains pressure is higher than 3 bar, install a pressure reducer on the load.

Install suitable filters on the water inlet pipes of the appliance according to the quality of the supply water.

**⚠** At the end of the installation it is necessary that the installer verify the good thermal insulation of every pipe and fitting present in the hydraulic compartment.

**⚠** In critical cases (hot and humid indoor air and low water temperature) it is possible to have water leaks from the base due to condensation on the connecting pipes used by the installer.

## Hydraulic connections

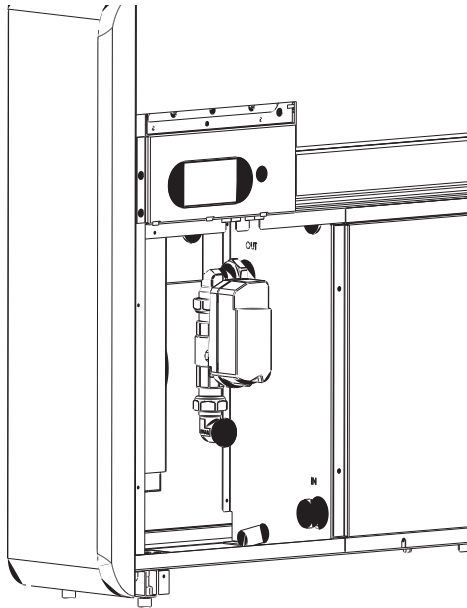

### IMPORTANT

the inversion of the inlet/outlet connection can cause the appliance to malfunction and damage

## Hydraulic device to be integrated for safety

As previously mentioned, the installer will have to provide some devices for the safety and correct maintenance of the appliance. In particular, the device shown in the figure

below must be installed.

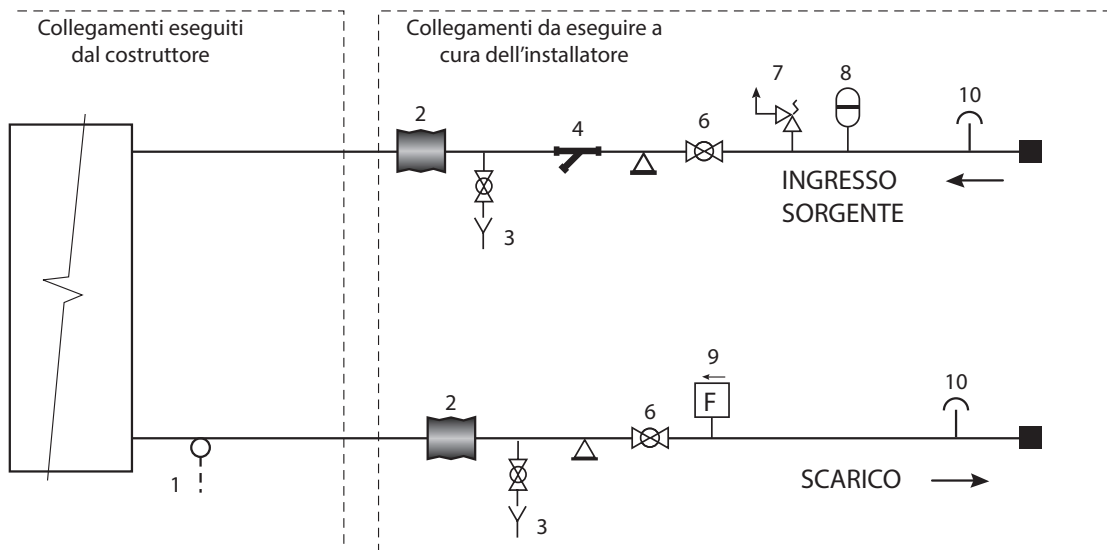

### LEGEND

- 1 Temperature probe
- 2 Anti-vibration joint
- 3 Exhaust valve
- 4 Net filter
- 5 /
- 6 Interception valve
- 7 Safety valve
- 8 Expansion vessel (possible for water hammers)

- 9 Flow switch (only for application with waste water)
- 10 Vent valve

### IMPORTANT

The vent valve must be positioned at the highest point of the circuit.

# Installation

## 2.7 Hydraulic and chemical characteristics of water

The internal water supply circuit has (as option) a two-way modulating valve, driven directly from the interface by the machine controller, which monitors the temperature of the water leaving the heat exchanger by regulating the flow of water to the heat exchanger for the maintaining 10 C ° n heating and 35 C ° tags in cooling, in order to minimize consumption and maximize returns.

The KVS of the valve used is:  
 $K_v \text{ (m}^3 \text{ / h with } \Delta p = 100\text{kPa} = 1\text{bar)} = 1.2$

The general expression (valid for water or technically similar fluids) for the calculation of load losses, knowing the value of the flow rate, is as follows:

$$\Delta P \text{ [bar]} = \left[ \frac{Q \text{ [m}^3\text{/h]}}{k_v} \right]^2$$

During the initial start-up phase, the specialized technician must identify the reference values of the system water with

the appropriate test kits.

### System water reference values

pH		6,5 ÷ 7,8
Electric conductivity	μS/cm	250 ÷ 800
Total hardness	°F	5 ÷ 20
Total iron	ppm	0,2
Manganese	ppm	< 0,05
cChloride	ppm	< 250
Sulfur ions		absent
Ammonia ions		absent

If the total hardness is higher than 20 ° F, or some reference values of the make-up water do not fall within the indicated limits, contact our pre-sales service to determine the treatments to be implemented.

Well or ground water not coming from the aqueduct must always be analyzed carefully and in case it is conditioned by suitable treatment systems. In case of installation of a water softener in addition to following the manufacturer's instructions, adjust the hardness of the outlet water not below 5 ° F (also performing the pH and salinity tests) and check the concentration of chlorides in output after resin regeneration.

## 2.8 Electrical connection

The appliance is equipped with a power cable with plug type F + E (CEE 7/7 schuko plug).

The cable can only be replaced by the manufacturer, service center or qualified installer. If you use an electrical outlet near the appliance, all you have to do is insert the plug.

- ⚠** Before connecting the conditioner check that:
- The power supply voltage and frequency values comply with the data plate of the appliance.
  - The power supply line has a suitable earth connection and that it is sized for the maximum absorption of the conditioner (minimum cable section equal to 1.5 mm<sup>2</sup>).
  - Power is only supplied using a suitable socket through the supplied plug.

**⚠** If the supply cable is replaced, this must be done exclusively by the technical assistance service or by authorised personnel and in compliance with current national regulations.

**⚠** The appliance must be connected to 230V/50 Hz mains via an omnipolar switch with a contact opening distance of minimum 3 mm, or using a device enabling the complete disconnection of the appliance in overvoltage III category conditions.

It is possible to carry out the electrical connection using a cable inside of the wall as indicated in the installation template (recommended for installations in the upper part of the wall).

Please check that the power supply is provided with suitable protections against overloads and/or short-circuits (using a 10 Amp Time delay fuse or other equivalent devices is recommended).

To prevent any risk of electrocution, always disconnect the main circuit breaker before making electric connections or performing any maintenance on the units.

To carry out direct connections and substitute the power cord using the cable in the wall, proceed as follows:

- Remove the upper grill.
- Remove the two plastic side panels, by lifting them upwards.
- Undo the front panel fixing screws.
- Remove the front panel.
- Disconnect the power cord by unscrewing the 3 screws from the terminal block.
- Connect the wall cable, checking that the power supply line has a suitable earth connection and that it is sized for the maximum absorption of the conditioner (minimum cable section equal to 1.5 mm<sup>2</sup>).

### Auxiliary Load Supply (for external 2-way pumps or valves)

The electrical terminal board, in addition to the connections required to connect the power supply, is designed to connect an auxiliary load.

The auxiliary load is activated 75 seconds before the compressor starts and is deactivated when the

compressor is switched off.

The maximum connectable load is 1A.

**⚠** The output does not support motors using starting capacitors, it will be the installer's responsibility to verify that the circulator installed is of electronic type.

<b>A</b>	230V/50 Hz Electrical power supply terminal block
<b>B</b>	CP contact presence
<b>1</b>	Upper grill

<b>2</b>	Plastic side panels
<b>3</b>	Front panel
<b>4</b>	Fixing screws

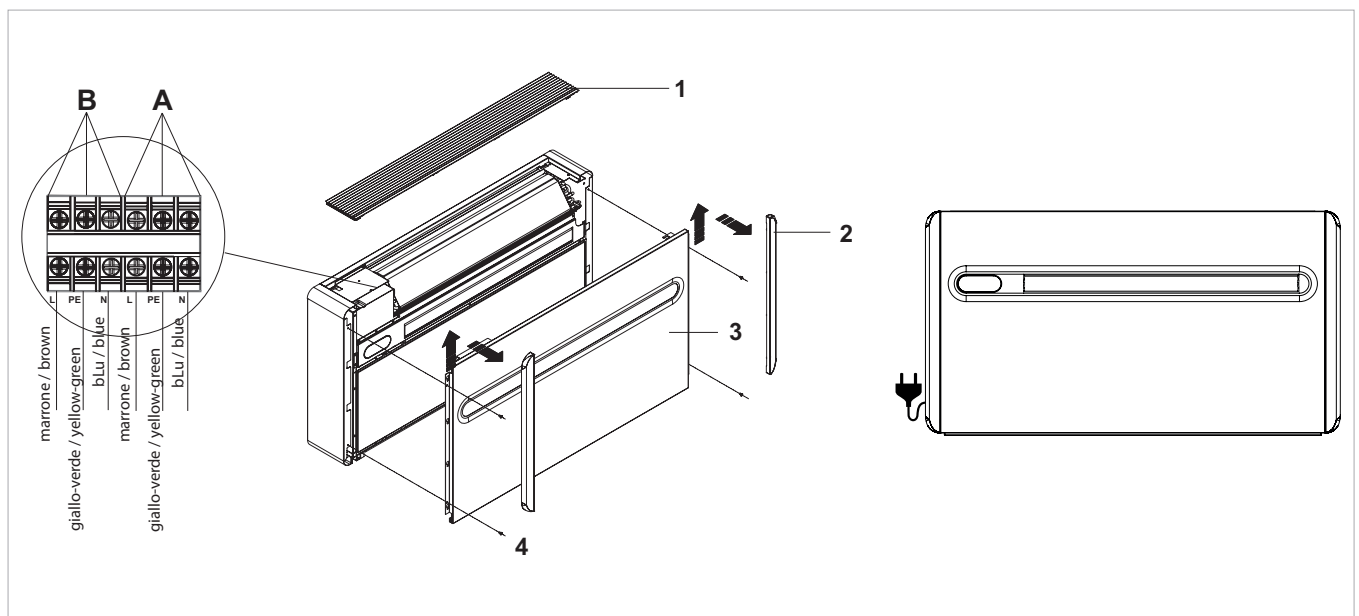

# Installation

## CP occupancy contact input connection

When the CP contact opens (very low voltage, connected to a free non-live contact) the appliance is put in stand-by and CP appears on the display.

Using this contact, it is possible to connect an external device that inhibits the functioning of the appliance

such as: open window contact, on/off remote, infrared presence sensors, enabling badge, etc.

We recommend using a double insulation cable.

## 2.9 High/low installation configuration

The unit can be installed either in the lower part (near the floor) or in the upper part (near the ceiling) of the wall. In order to optimise air distribution and comfort, the direction of the air flow can be modified by adjusting the position of the air flap.

The appliance is supplied ready to be installed in the lower part of the wall, so the air flow is directed upwards. The same configuration can also be used in the upper part of the wall in cooling mode, which increases the air flow in

the room (coanda effect).

In this case, purchase the the lower cover decorative kit code GB0737.

**⚠** This operation must be performed while the appliance is switched off and disconnected.

### Modification from lower wall to the upper wall installation

- Open the air outlet flap gently
- Remove the flap opening block insert located internally on the right of the air outlet mouth and place it in the lower hole.
- Remove the upper grill
- Remove the two plastic side panels by moving them up

- Unscrew the fixing screws
- Remove the front panel
- Place the bottom cover and fix it with the supplied screws (optional kit GB0737)
- Refit in the reverse order.

<b>A</b>	High installation
<b>B</b>	Low installation (factory settings)
<b>1</b>	Block insert
<b>2</b>	Lower cover (kit code GB0737)

<b>3</b>	Fixing screws (supplied with the optional kit GB0737)
<b>4</b>	Upper grill
<b>5</b>	Plastic side panels
<b>6</b>	Front panel

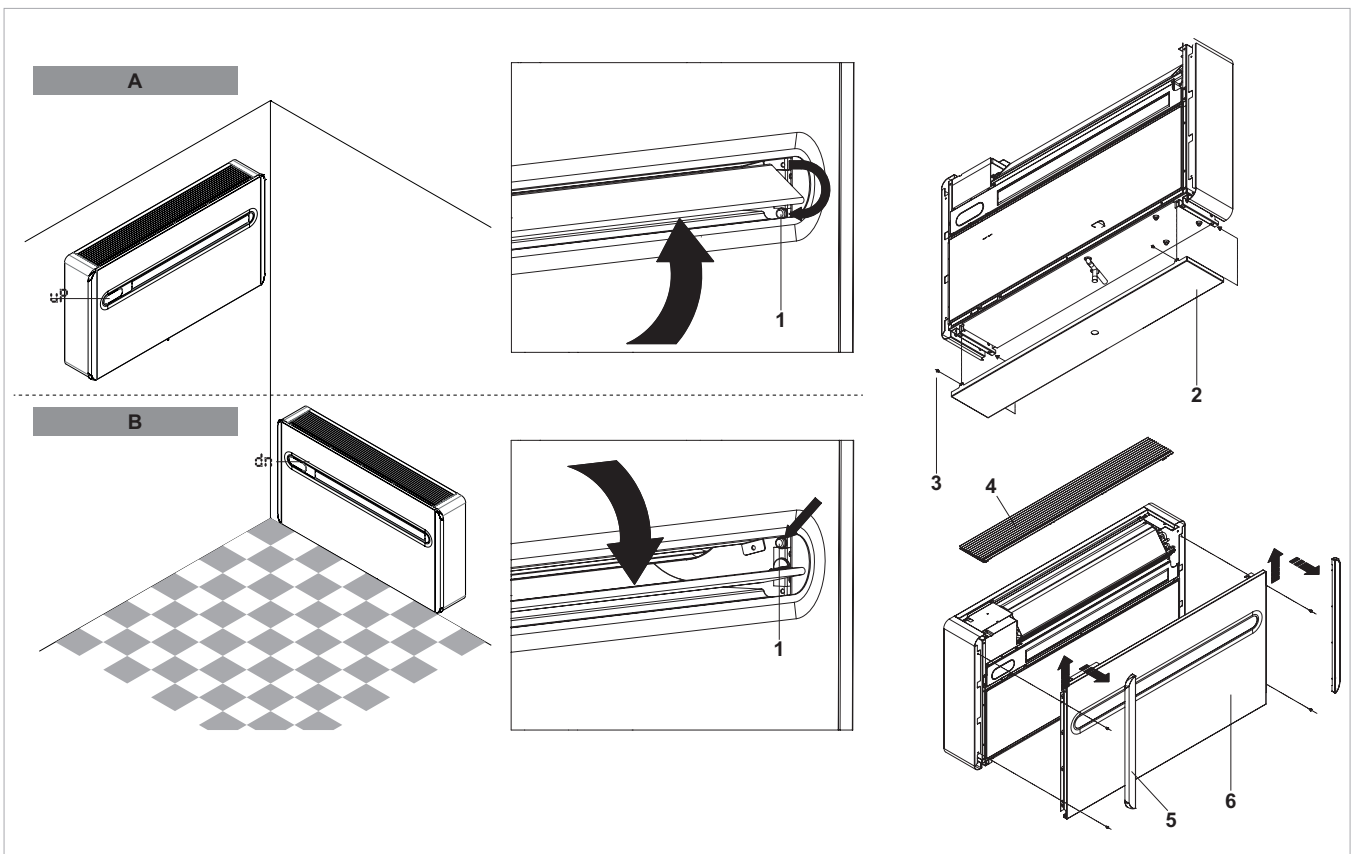

After adjusting the air outlet flap position, it is necessary to set up the electronic control of the appliance:

- Keep pressed the **↔** button on the display for 5 seconds;
- The **dn** (lower wall) symbol flashes on the display;
- Press the **↔** key again;
- The **up** (upper wall) symbol lights up on the display.

- If no other operations are performed in the following 2 seconds, the new setting is memorised.

**⚠** For the appliance to work properly, each time the configuration of the air outlet flap is modified, the electronic control must be set.

# Installation

## 2.10 Setting cool only or heat only modes

It is possible to deactivate the heating or the cooling modes following a simple procedure.

Keep the A key on the touch-screen display pressed for 5 seconds until HC (heating and cooling) appears on the display.

Press the A key for 1 second to switch to the Co (cooling

only) mode.

Press the A key again to switch back to Ho (heating only) mode.

Wait for 3 seconds without touching anything to memorise the setting.

## 2.11 Brightness regulation

The display brightness sensor can be disabled (leaving the maximum brightness at all times) by pressing and holding

the night button  for 10 seconds. "ds" (disabled) or "En" (enabled) will appear on the display.

## 2.12 Touch-screen display key lock

The key lock is activated by keeping the Timer  symbol on the touch-screen display pressed for three

seconds.

The user cannot perform any actions.

The stand-by symbol flashes every second.

To deactivate the lock, keep the Timer symbol pressed for three seconds once again.

The lock remains active also for the next operations performed via remote control and in the event of a power failure.

## 2.13 Hotel function

Press and hold the air exchange key  for 10 seconds to enable the function ("En" displayed); the dehumidification and Auto functions are disabled (leaving active only ventilation, heating and cooling) and the settable set range

is reduced from 22 to 28 in cooling mode and from 16 to 24 in heating mode).

## 2.14 Detecting possible faults

If the conditioner blocks because of an alarm (see following table), please communicate to the assistance centre the

code on the display to facilitate interventions.

Display indications	Cause
E1	Faulty room temperature RT probe
E2	Faulty evaporative battery IPT probe
E3	
E4	Faulty conditioner battery OPT probe
E5	Faulty indoor air fan motor
E6	Faulty outdoor air fan
E7	Lack of communication with the display
E8	Compressor discharge probe failure (only for DC Inverter models)

## Open CP contact

If the presence contact is not closed, the appliance will not start and the **CP** alarm appears on the display.

## Evacuation of condensate water in the event of an emergency

Should any anomaly occur in the condensation water system, the maximum level float blocks the conditioner and the **OF** code appears on the display.

During cooling and dehumidification, electronics keeps the water distribution system active with the battery - together with the fan - to disperse excess water in the container. If the problem persists, please contact the assistance

service.

During heating, condensation should drain freely through the specific pipe. In the event of an alarm, check that the condensation pipe is not bent or obstructed, thus preventing the water from flowing out.

## Use of the appliance

- ⚠ Objects or structural obstacles (furniture, curtains, plants, leaves, blinds, etc.) must not obstruct the normal air flow both from the internal and from the external grids.
- ⚠ Do not lean against, or worse sit on, the body of the conditioner, this would damage the appliance.
- ⚠ Do not move the horizontal air outlet flap manually. Always use the remote control to perform such operation.
- ⚠ In the event of water leaks, turn off the appliance and disconnect the electric power supply. Call the nearest service centre.
- ⚠ The appliance must not be installed in rooms where explosive gases develop or where there are humidity and temperature conditions that exceed the maximum levels reported on the installation manual.
- ⚠ Clean the air filter regularly as described in the specific paragraph.

## Operations after installation

Before leaving the site, the packaging should be gathered up and all traces of dirt that have deposited on the unit during assembly should be eliminated with a damp cloth. These operations, which are not strictly necessary, in any case allow for a more professional appearance of the installation in the eyes of the user.

To avoid unnecessary calls by the user, before leaving the site it is also a good idea to:

- outline the contents of the manual,
- show them how to clean the filter,
- explain when and how they should contact Customer Service.

# Maintenance

## MAINTENANCE

### 3.1 Periodic Maintenance

The air conditioner you have bought has been designed to keep maintenance operations to a minimum, in fact, they

only include the following cleaning operations:

#### External cleaning

- ⚠ Disconnect the unit from the power supply before each cleaning and maintenance intervention by setting the main power supply switch to off.
- ⚠ Wait for the components to cool down in order to avoid any burns.

- ⚠ Pay attention to the sharp edges.
- ⚠ Do not use abrasive sponges or abrasive or corrosive detergents as you might damage the painted surfaces.

When necessary, clean the external surfaces with a soft damp cloth.

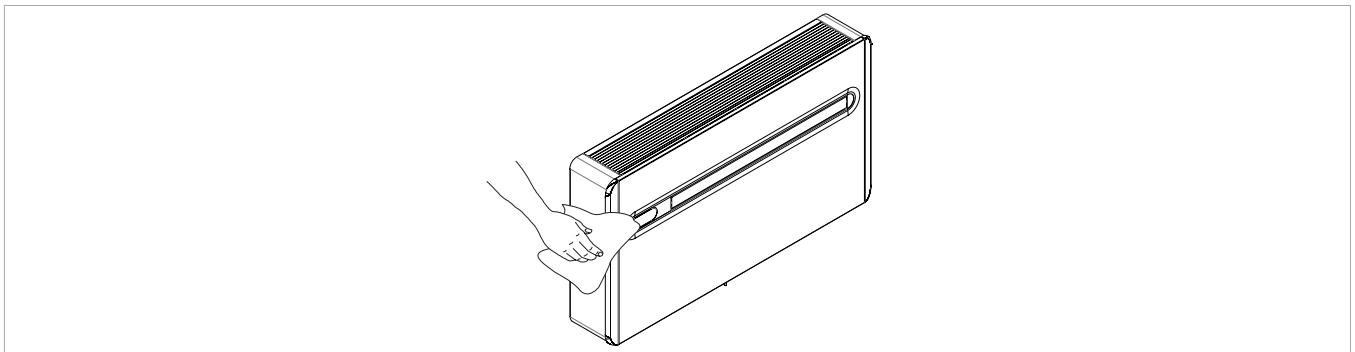

#### Cleaning the filters

The air conditioner you have bought has been designed to keep maintenance operations to a minimum, in fact, they only include the following cleaning operations:

Clean the air filter after a period of continuous use and according to the concentration of impurities in the air, or when you wish to start-up the appliance after a period of inactivity.

NB: before performing any operation, take care with the hot and/or sharp surfaces of the metal.

The filter is located in the top part of the appliance.

To extract the filter:

- open the grille and carry out operations 1, 2, 3, then remove it from its housing;
- extract the filter by lifting it;
- remove the dust from the filter with a vacuum cleaner or by washing it in running water without using detergents or solvents and leave to dry;
- put the filters back on top of the coils, taking care to position them correctly;
- put the grille back in reverse order.

- ⚠ After filter cleaning, check if the panel is properly mounted.

- ⊘ It is forbidden to use the device without its mesh filter.

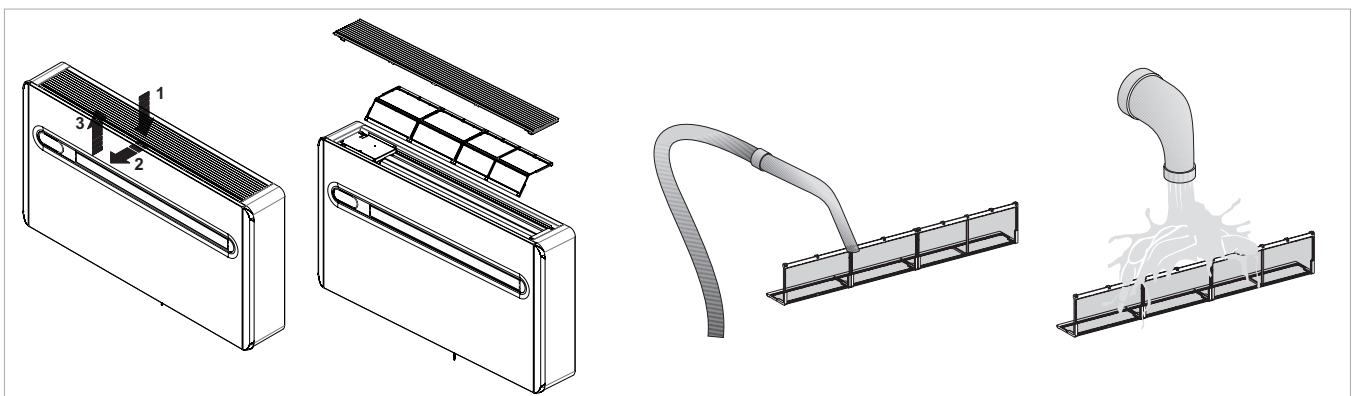

## 3.2 Troubleshooting

In the even of a malfunction, please refer to the following table. If, after performing the suggested checks, the problem is not solved, please contact the authorised technical assistance.

Fault	Possible causes	Solution
The appliance doesn't switch on	No power supply	Check there is power supply (by turning a light on, for example). Check that the thermal-magnetic circuit breaker used exclusively to protect the appliance has not been tripped (if it has, reset it). If the problem repeats immediately, please call the Service Centre and avoid trying to make the appliance work.
	Remote control batteries have run out	Check that the appliance can be turned on using the touch-screen display and substitute the batteries.
The appliance does not cool/heat adequately.	The temperature set is too high or too low.	Check and, if necessary, adjust the temperature setting on the remote control
	The air filter is clogged	Check the air filter and clean it if necessary
	Check that there are no other obstacles to the air flow both inside and outside.	Remove anything that might block the air flow.
	The heating and cooling load has increased (for example, a door or a window has been left open or an appliance has been installed in the room which generates a lot of heat).	Try to reduce the heating and cooling load of the room following instructions below: Cover large windows exposed to sunlight with curtains or with external maskings (blinds, porches, reflecting films, etc.); The air conditioned room must remain closed for as long as possible; Avoid turning on halogen lamps or other high energy consumption appliances such as small ovens, steam irons, hot plates etc.).

## Display alarms

An alarm code appears on the display in the event of faults. Some of the functions, however, remain active (see FUNCTIONING column).

Alarm	Cause	Operation
E1	Faulty room temperature RT sensor	It is still possible to activate Cooling, Dehumidification and Heating modes. It only monitors the antifreeze function of the internal coil.
E2	Faulty internal coil IPT sensor	None of the modes can be activated.
E3		
E4	Faulty external coil OPT sensor	It is still possible to activate Cooling, Dehumidification and Heating modes. Defrosting is performed at fixed times.
E5	Faulty internal fan motor	None of the modes can be activated.
E6	Faulty external fan motor	None of the modes can be activated.
E7	Lack of communication with the display *	None of the modes can be activated.
E8	Compressor discharge probe failure *	None of the modes can be activated.
CP	Open CP contact	The appliance only works if the contact is closed. Check that the clamps are connected.
OF	Maximum level float intervention	During cooling and dehumidification, electronics keeps the water distribution system active with the battery - together with the fan - to disperse excess water in the container. During heating, condensation should drain freely through the specific pipe. In the event of an alarm, check that the condensation pipe is not bent or obstructed, thus preventing the water from flowing out.

\* for DC Inverter models: lack of communication between the main, power, driver or display boards

The only way to solve the problem is to disconnect and reconnect the appliance. If the alarm still appears, please contact the authorised technical assistance.

# Maintenance

## 3.3 Technical specifications

Please read data plate to obtain the technical data listed below.

- Power supply voltage
- Maximum absorbed power
- Maximum absorbed current
- Amount of refrigerant gas
- Casing protection rating

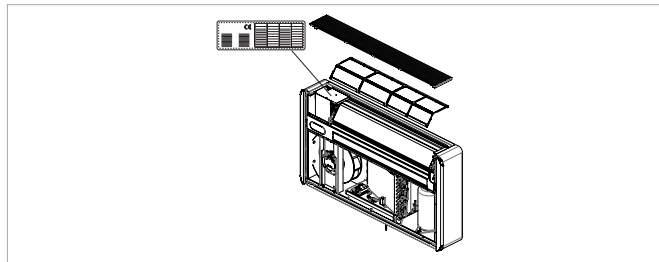

	U.M.	Vision 3.1 Inverter H2O
<b>Technical specifications</b>		
Cooling power (1)	kW	2,96
Power in max cooling mod. Dual Power	kW	3,60
Heating power (2)	kW	3,10
Power in max heating mod. Dual Power	kW	3,84
Power absorbed when cooling (1)	W	730
Power absorbed when heating (2)	W	720
Dehumidification capacity	L/h	1.3
Power supply voltage	V-F-Hz	230-1-50
EER	W/W	4.05
COP	W/W	4.31
Internal-external ventilation speed	Nr.	3
Internal/external air flow at max speed	m³/h	400
Internal/external air flow at medium speed	m³/h	320
Internal/external air flow at min speed	m³/h	270
Water flow max.	L/h	620
Dimensions (WxHxD)	mm	1010x549x165
Weight including packaging	kg	49,5
Sound pressure level (min-max) (4)	dB(A)	27/41
Unit sound power level inside (min-max) (5)	dB(A)	42/54
Refrigerant gas		R410A
Qty. R410A refrigerant gas	g	560
Global warming potential (GWP 2088)	kgCO <sub>2</sub> eq.	1.169
Maximum absorbed power	W	1.220*
Maximum absorbed current	A	5.6*
Maximum working pressure PS	MPa	3,8
Protection rating		IPX0

\* with Dual Power function activated during heating

### Reference conditions

		Room T	External T
(1)	Cooling mode tests (EN 14511)	DB 27°C - WB 19°C	IN 30 °C - OUT 35 °C
(2)	Heating mode tests (EN 14511)	DB 20°C - WB 15°C	IN 15 °C - OUT 12 °C
(3)			
(4)	Internal side sound pressure measured in semi-anechoic chamber at a distance of 2 m.		
(5)	Internal side sound pressure measured in accordance with regulation EN 12012		

### Operating limits

	Internal ambient temp.	
Maximum operating temperature in cooling mode	DB 35°C - WB 24°C	
Minimum operating temperature in cooling mode	DB 18°C	
Maximum operating temperatures in heating mode	DB 27°C	
Minimum operating temperatures in heating mode	DB 5°C	

## RED Compliance Statement

### Compliance with 2014/53/EU Radio Equipment Directive (RED).

In accordance with Article 10.8(a) and 10.8(b) of the RED, the following table provides information on the frequency

bands used and the maximum RF transmit power of the product for sale in the EU:

Frequency range (MHz)	Max. Transmit Power (dBm)
2400-2472	< 20

Hereby, the company declares that the device is in compliance with Directive 2014/53/EU.

 For declarations of conformity, certificates and other certification details please consult the website.

This equipment should be installed and operated with a minimum distance of 20 centimeters between the radiator and your body.

## Safety

This equipment is designed with the utmost care for the safety of those who install and use it. However, special attention must be paid to the dangers of electric shock and static electricity when working with electrical equipment.

All guidelines of this and of the computer manufacture must therefore be allowed at all times to ensure the safe use of the equipment.

# Getting In Touch

Powrmatic Limited  
Hort Bridge, Ilminster  
Somerset  
TA19 9PS  
tel: **+44 (0) 1460 53535**  
fax: **+44 (0) 1460 52341**  
e-mail: **info@powrmatic.co.uk**  
web: **www.powrmatic.co.uk**



Powrmatic Ireland  
45 Broomhill Close  
Tallaght  
Dublin 24  
tel: **+353 (0) 1452 1533**  
fax: **+353 (0) 1452 1764**  
e-mail: **info@powrmatic.ie**  
web: **www.powrmatic.ie**

More information is available from our website by scanning the following QR code.



Powrmatic pursues a policy of continues improvement in both design and performance of its products and therefore reserves the right to change, amend or vary specifications without notice. Whilst the details contained herein are believed to be correct they do not form the basis of any contract and interested parties should contact the Company to confirm whether any material alterations have been made since publication of this brochure.