



Ultrasky

Glazed Ultrasky Ventilator Smoke & Natural Ventilator

Tested to BS-EN 12101: Part 2: 2003

Overview

The Ultrasky AOV vent is a high quality glazed ventilator designed for both smoke and natural ventilation requirements, tested to BS EN12101-2. Its extremely low air permeability characteristics, low profile and aesthetic features offer the ideal solution for modern buildings. Ultrasky has been specifically designed for seamless integration into inclined and vertical glazing systems.

Product Specification

Construction

Aluminium Extrusion

Sizes & Weights

Available in increments from 500 mm to 2000 mm high and 500 mm to 2700 mm wide. The maximum weight is 165kg.

Aesthetic Design

The Ultrasky has a very attractive design and appearance. This is down to:

- Compact frame dimensions
- Only 37mm offset between fixed and window glazing
- Completely concealed hinges
- No screws and no glass bead

Controls

- 24v Drive Open/Drive Close actuators (chain or spindle) for smoke ventilation schemes
- 230v Drive Open/Drive Close actuators (chain or spindle) for natural ventilation schemes

Finish Options

- Natural anodised
- Polyester powder coated to a BS Standard or RAL colour

The Ultrasky can also have Bi-Color finishes with alternative colours externally and internally offering a unique design element.

Glass & Panel Types

Ultrasky can be fitted with either of the following:
(Glass thickness can range from 9 to 48mm)

- Single Glazed
- Double Glazed
- Triple Glazed
- Insulated Or Un-Insulated Aluminium
- Polycarbonate

Sealed Unit Structure

Due to its triple sealed system the Ultrasky can offer extremely low air permeability rates meeting the demands of new regulations. Within its extrusion the Ultrasky has a thermal break which helps reduce thermal heat loss and condensation build up.

Installation

Installation & Base Types

Inclined installation into glazing systems (type 105), can be installed down to 2 degrees. Vertical installation (type 50) into glazing or block work openings. Glazing adapters as standard and alternative installation options available.

- Turndown Base - mounting onto weathered roof up-stand
- Flat Base - mounting directly onto roof sheeting

The Ultrasky has completely concealed hinges and can be top hung, side hung or bottom hung.

Control Options & Certification

The Skyvent is available with the following standard controls:

Control Options	Tested To
24v Electric Drive Open/Drive Close Actuators (Chain Or Spindle)	EN-12101

Testing

The Ultrasky has been tested to BS EN 12101 – Part 2: 2003: Specification for natural and heat exhaust ventilators.

Test	Class	Test	Class
Snow Load	SL-125	Temp (Low)	T (-5°C)
Fire Reaction	Class E	Temp (High)	B-300
Wind Load	WL-2000	Reliability	RE-1000

Technical Drawings

Ultrasky

- Typical Horizontal Ultrasky Detail (Bottom Hung - Spindle Actuator)

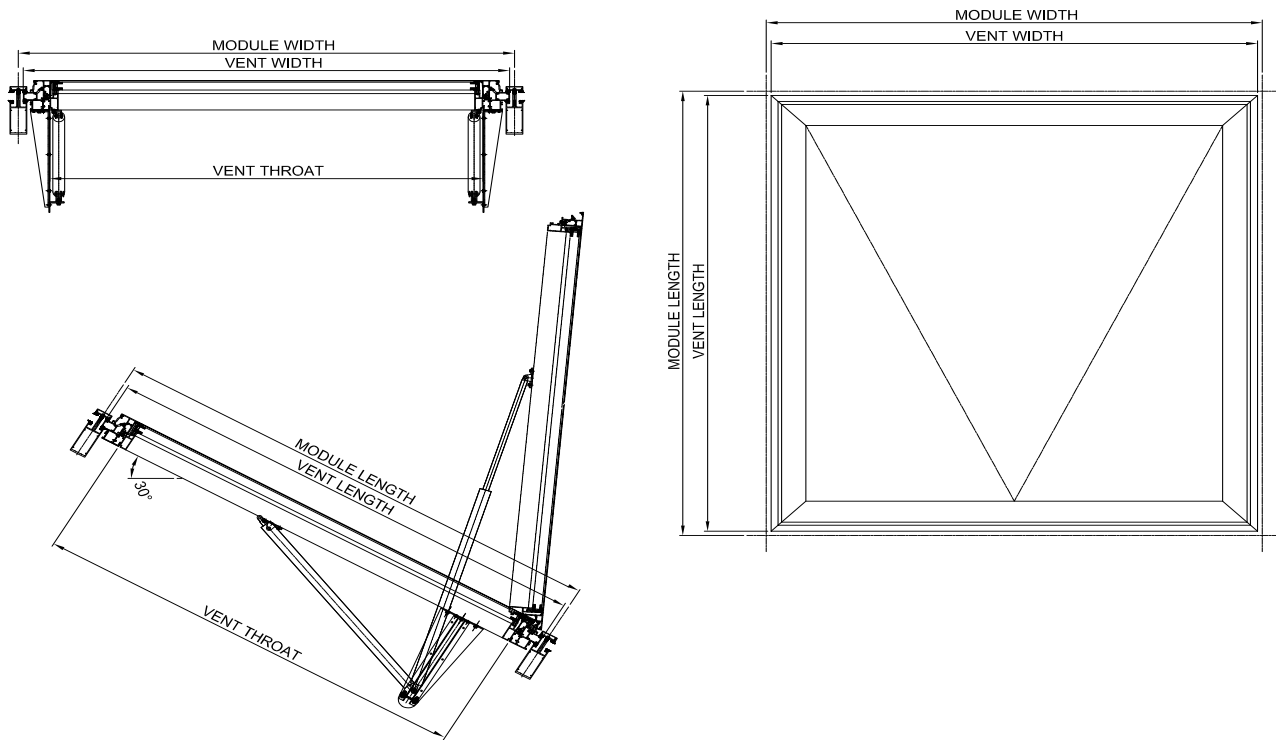

- Typical Vertical Ultrasky Detail (Bottom Hung - Chain Actuator)

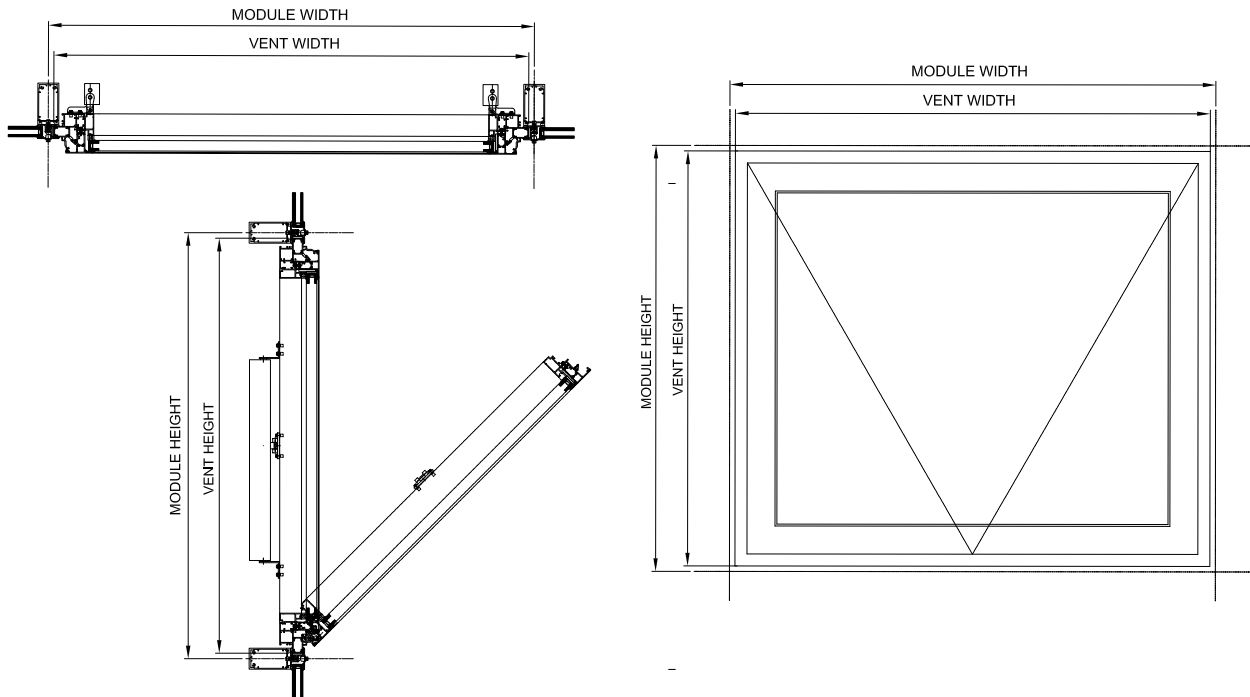

Contact one of the ventilation team to discuss any required technical information. We are unable to produce data tables because there are so many variables depending on the application.