

TB137

Applies to models:

PU, PL, PVU, PVL & PVDL



Radiant

Sports Guard Assembly

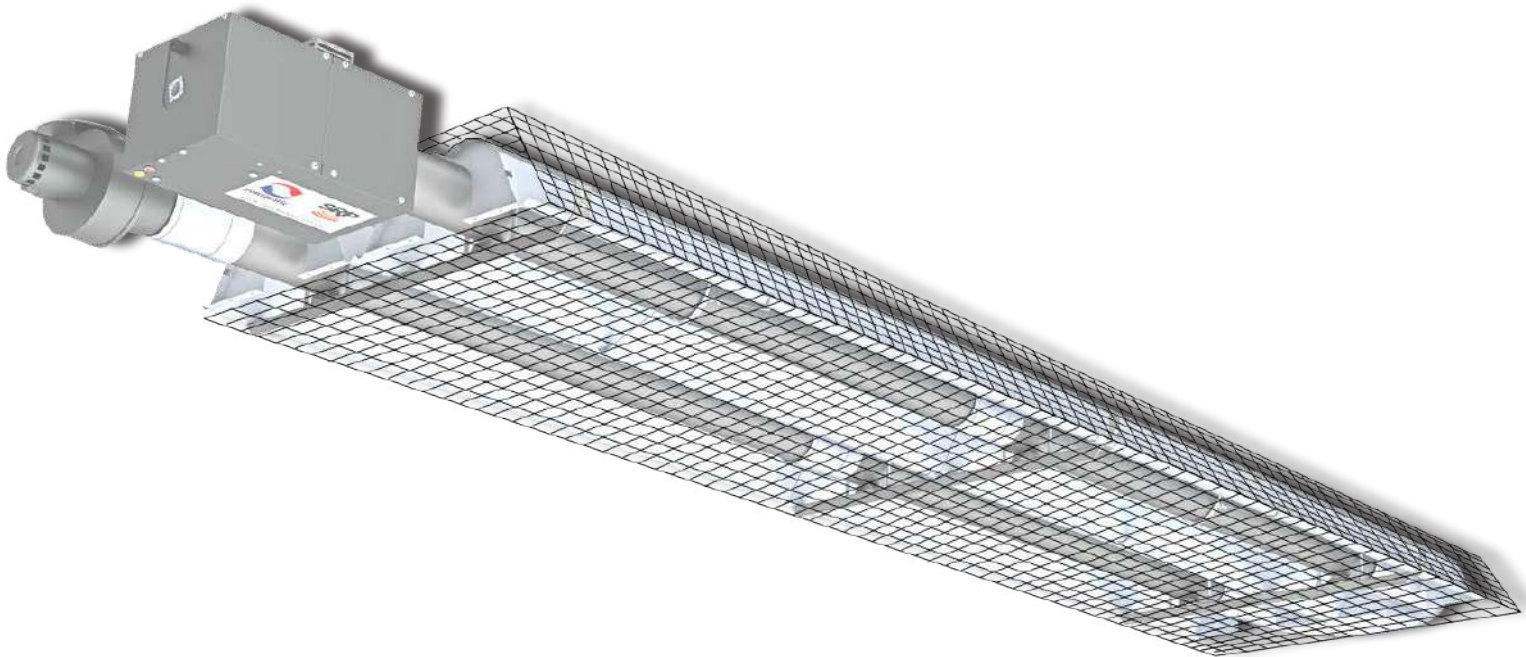

General Information

The Radiant Sports Guard system consists of top and bottom sections of heavy duty mesh, supported on the underside of the radiant tube.

These assembly instructions describe the parts required and procedures to be carried out when installing this option.

Ensure all components detailed in the chart below for your specific heater is to hand.

Parts & Tools required



PoziDrive screwdriver



Spanner Set



Pliers

Quantity of Parts								
Heater Models	Conversion Kit part number	Bottom Guard	Top Guard	M8 U Bolts	Mesh Clamp	M8 Coupling Nut	M8 Hex Cap Head Screws	Wire Clips
PL10	PL10-SG	2	2	6	12	12	12	20
PL20/PVL20	PL20-SG	6	6	18	36	36	36	60
PL30/PVL30	PL30-SG	6	6	18	36	36	36	60
PL40/PVL40	PL40-SG	8	8	24	48	48	48	80
PL50/PVL50	PL50-SG	12	12	36	72	72	72	120
PL60	PL60-SG	14	14	42	84	84	84	140
PU20/PVU20	PU20-SG	3	3	12	36	36	36	30
PU30/PVU30	PU30-SG	3	3	12	36	36	36	30
PU40/PVU40	PU40-SG	4	4	16	44	44	44	40
PVDL series	Quantities shown above x2							

Procedure PL & PVL

For PL & PVL heaters, there are THREE fixing points each sports guard - one central and one towards each end.

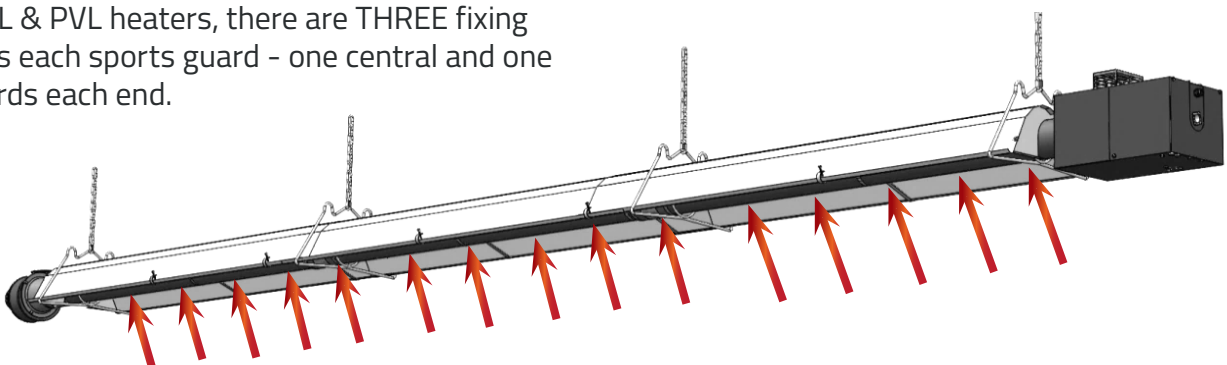

Procedure PL & PVL

Distribute the U bolts (1) along the length of the heater and position over the tube at points shown previously.

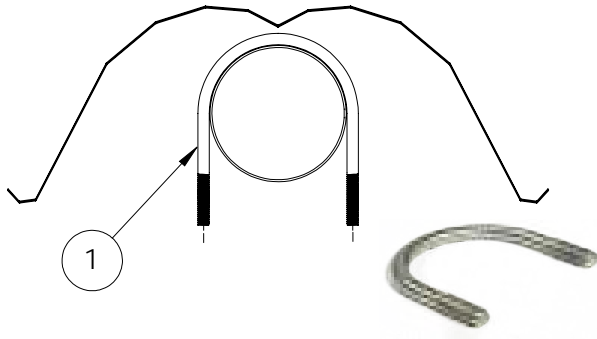

Attach a M8 coupling nut (2) onto each threaded end of the U bolts. (1)

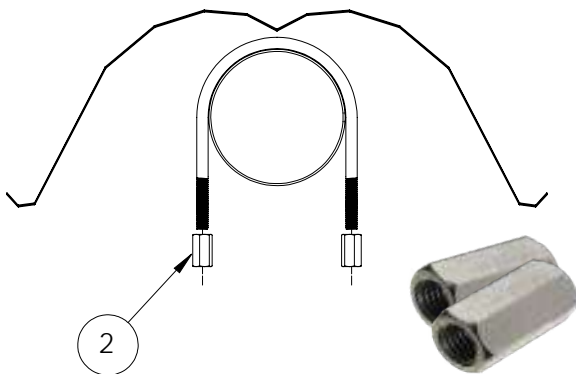

Offer a U bolt clamp (4) up to the coupling nuts (2) then the bottom guard mesh into position.

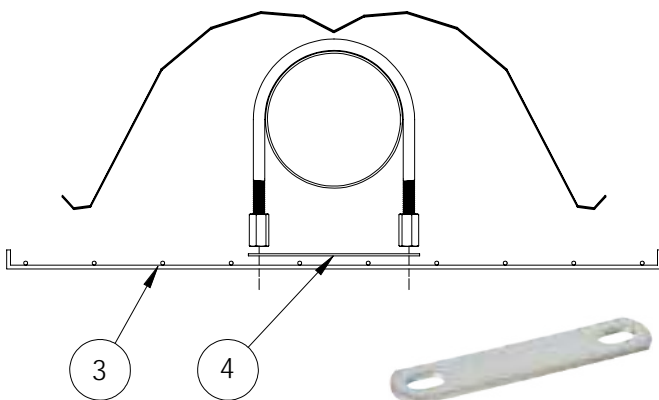

Offer another U bolt clamp (4) up to the guard mesh. Place a M8 x 16 bolt (5) through this clamp, the bottom mesh, (3) through the other clamp plate (4) and secure to the coupling nut (2)

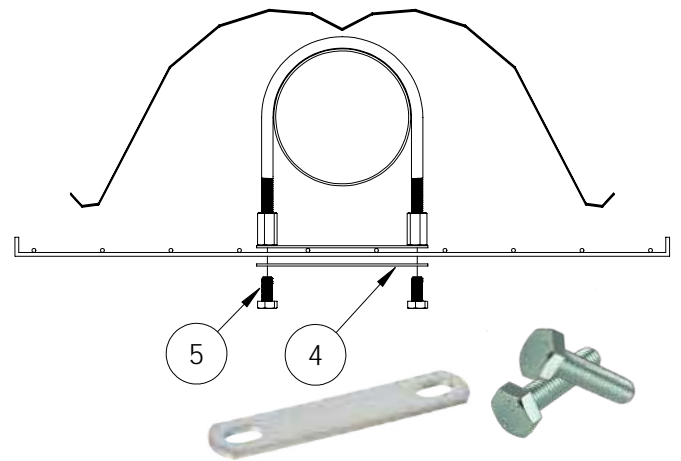

Place the top mesh (6) over the reflector ensuring each edge is located inside the fold of the bottom mesh.

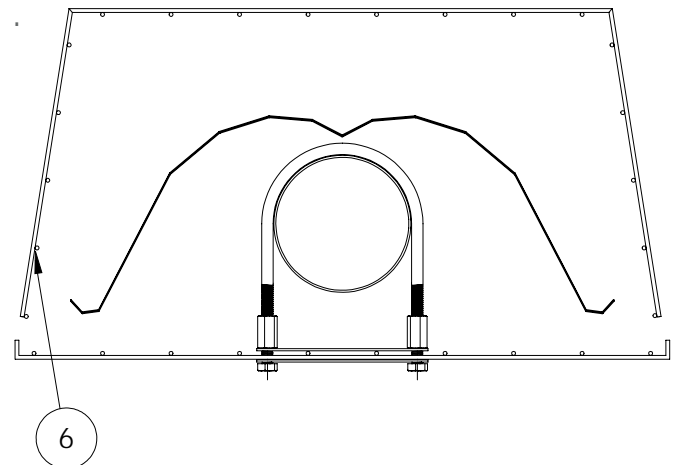

Fasten the wire clips (7) at regular intervals around the wire mesh bars where the top and bottom sections meet and close using a pair of pliers. Use additional wire clips to join each section along the length of the heater.

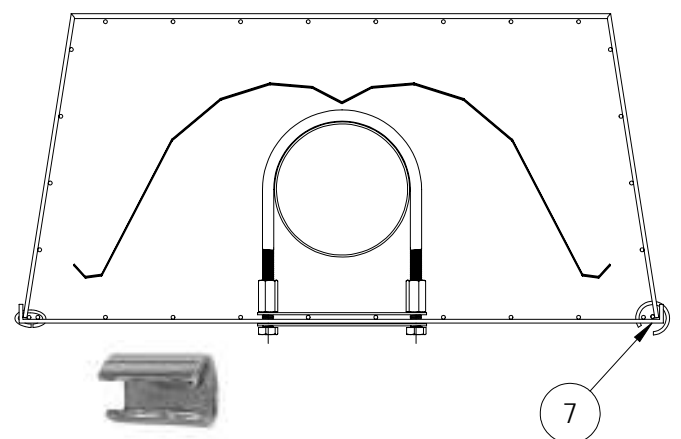

Procedure PU & PVU

For PU & PVU heaters, the sports guard fixing points are located at each support bracket and extra points in between.

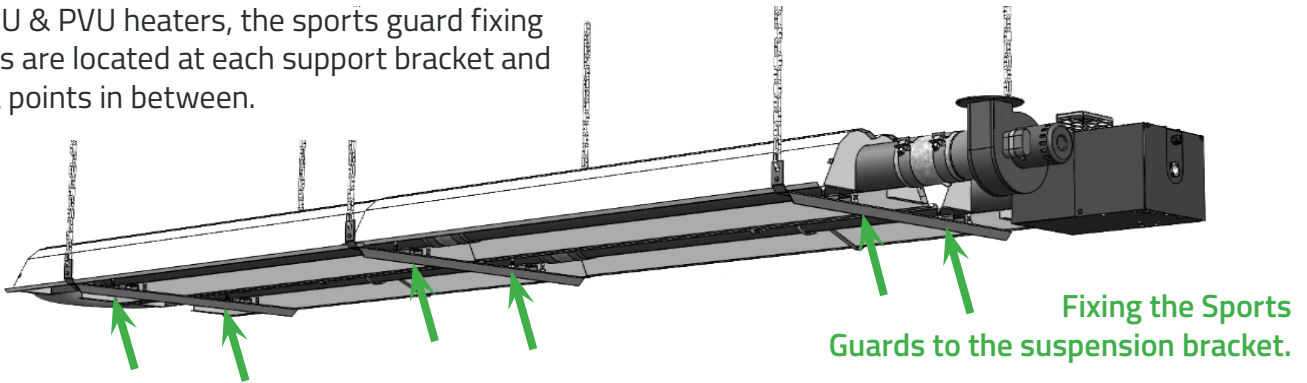

Attach a M8 coupling nut (2) onto each threaded end of the U bolts. (1)

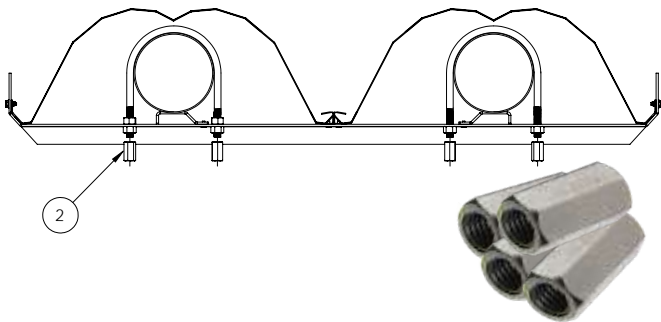

Place the top mesh (6) over the reflector ensuring each edge is located inside the fold of the bottom mesh.

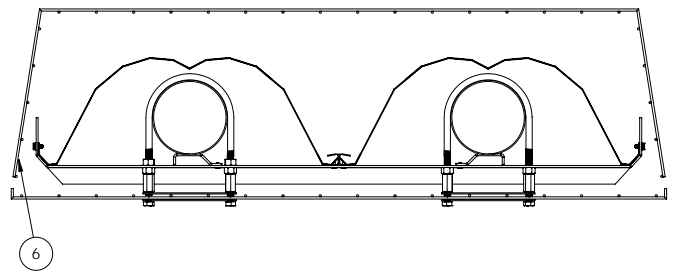

Offer a U bolt clamp (4) up to the coupling nuts (2) then the bottom guard mesh into position.

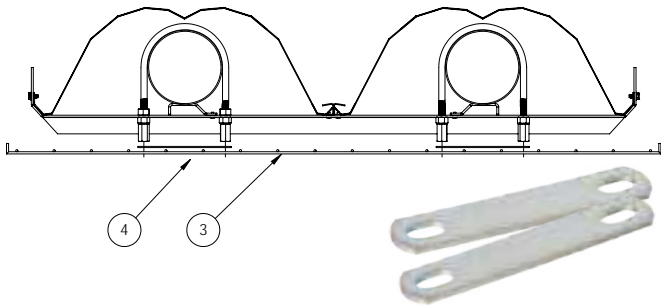

Fasten the wire clips (7) at regular intervals around the wire mesh bars where the top and bottom sections meet and close using a pair of pliers. Use additional wire clips to join each section along the length of the heater.

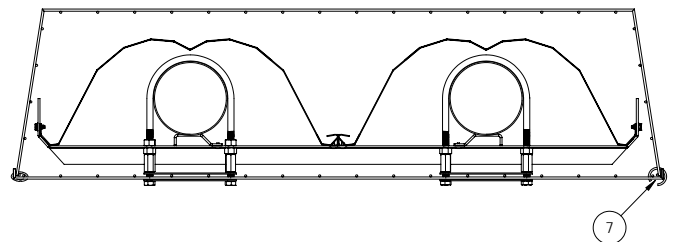

Offer another U bolt clamp (4) up to the guard mesh. Place a M8 x 16 bolt (5) through this clamp, the bottom mesh, (3) through the other clamp plate (4) and secure to the coupling nut (2)

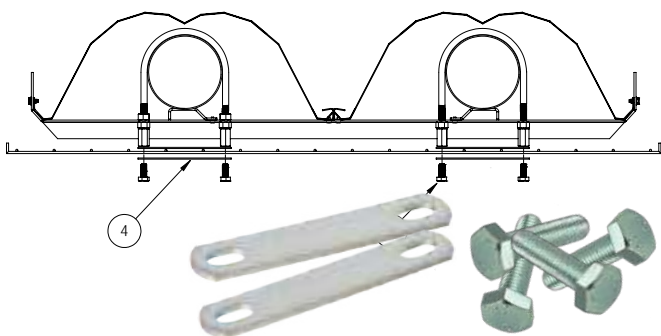

Completed assembly section from U bend

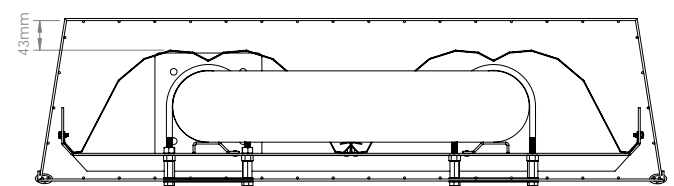

Procedure PU & PVU

Fixing the Sports Guards to the extra supports.

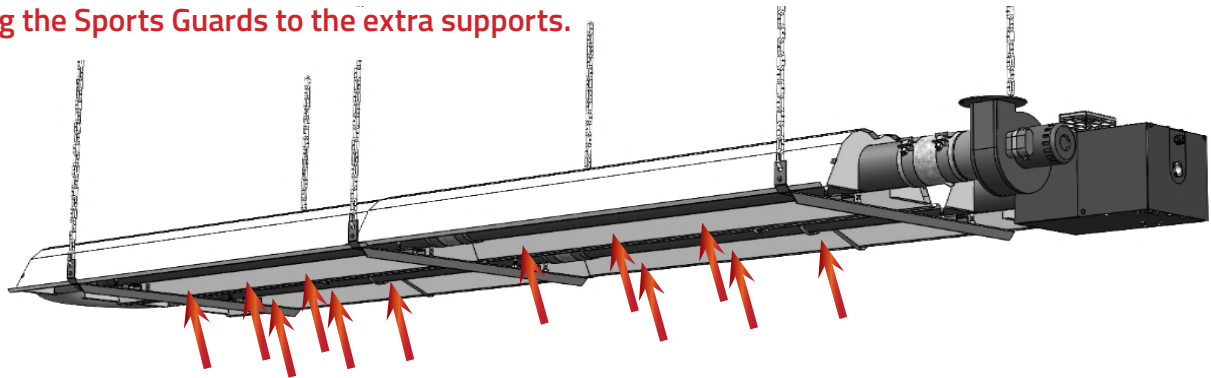

Distribute the U bolts (1) along the length of the heater and position over the tube at points shown previously.

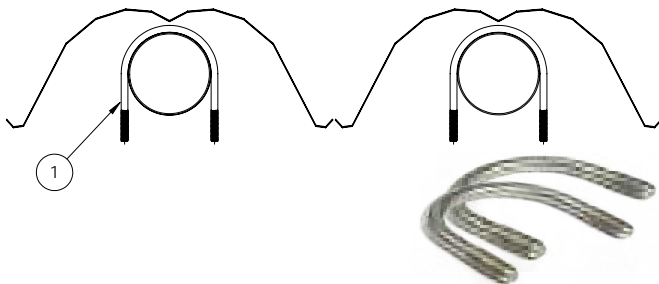

Attach a M8 coupling nut (2) onto each threaded end of the U bolts. (1)

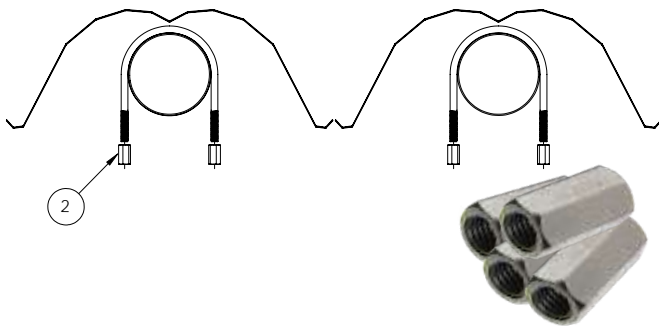

Offer a U bolt clamp (4) up to the coupling nuts (2) then the bottom guard mesh into position.

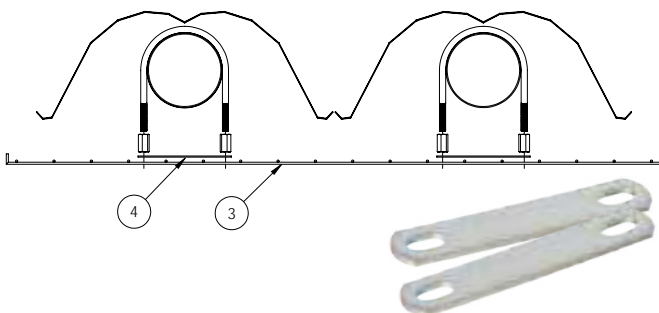

Offer another U bolt clamp (4) up to the guard mesh. Place a M8 x 16 bolt (5) through this clamp, the bottom mesh, (3) through the other clamp plate (4) and secure to the coupling nut (2)

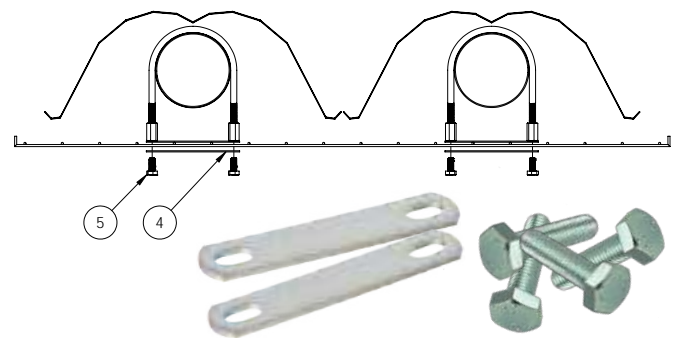

Place the top mesh (6) over the reflector ensuring each edge is located inside the fold of the bottom mesh.

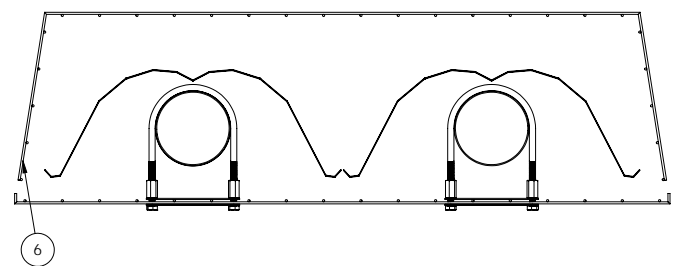

Fasten the wire clips (7) at regular intervals around the wire mesh bars where the top and bottom sections meet and close using a pair of pliers. Use additional wire clips to join each section along the length of the heater.

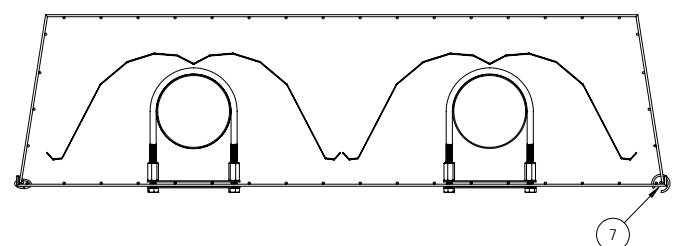

Fixing Points

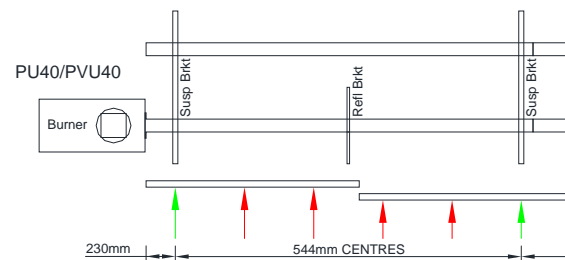
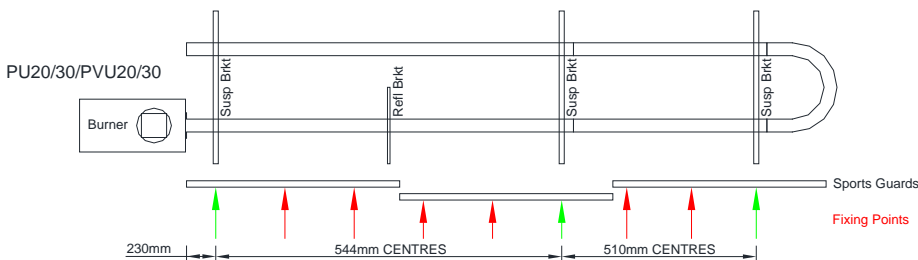
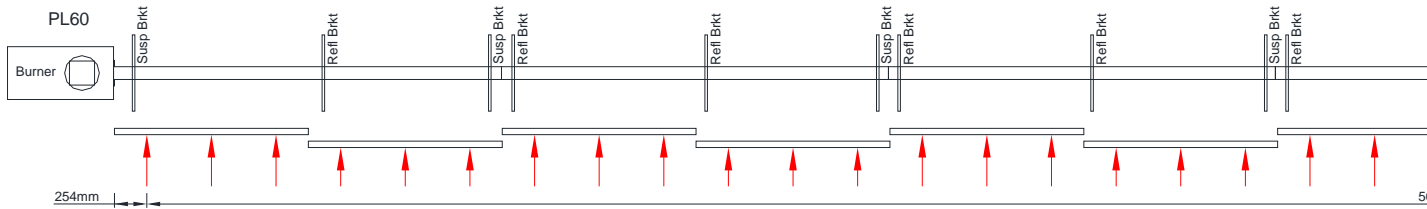
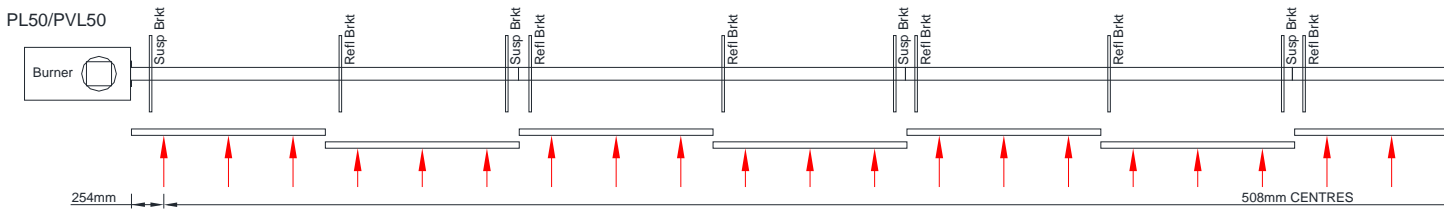
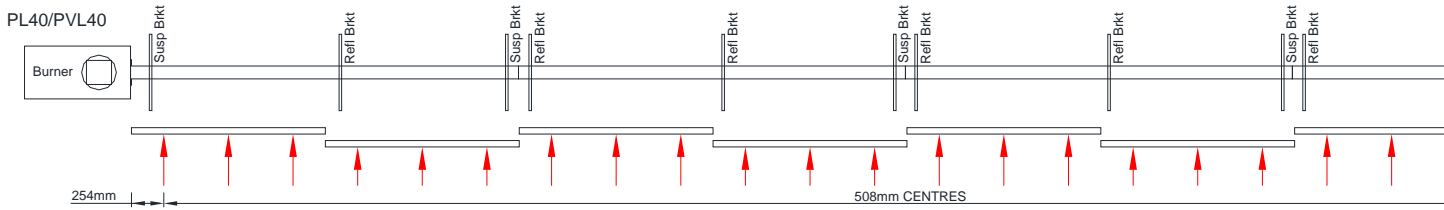
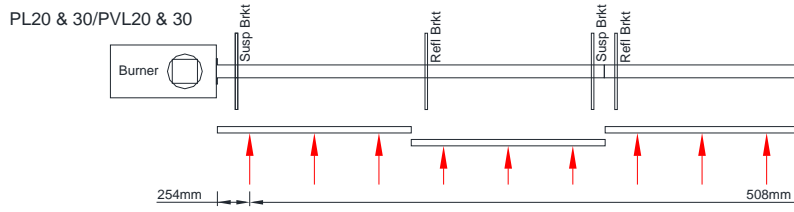
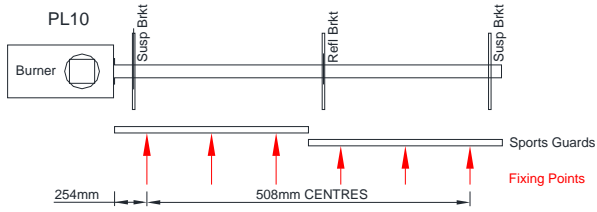

Fixing Points

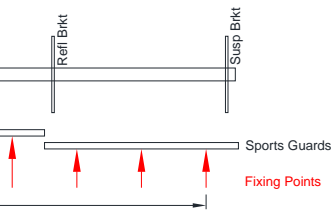
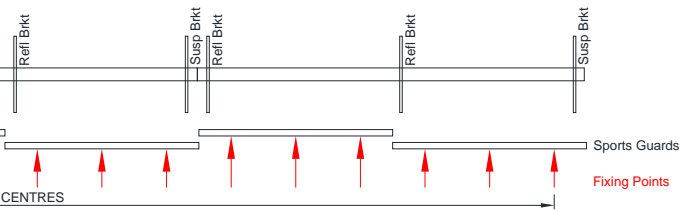

ADDITIONAL FIXINGS

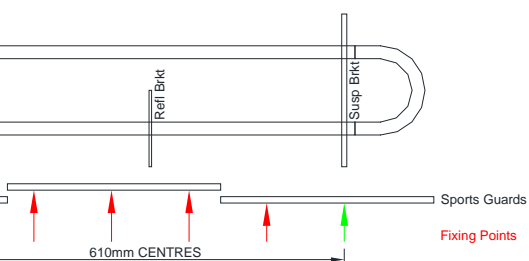
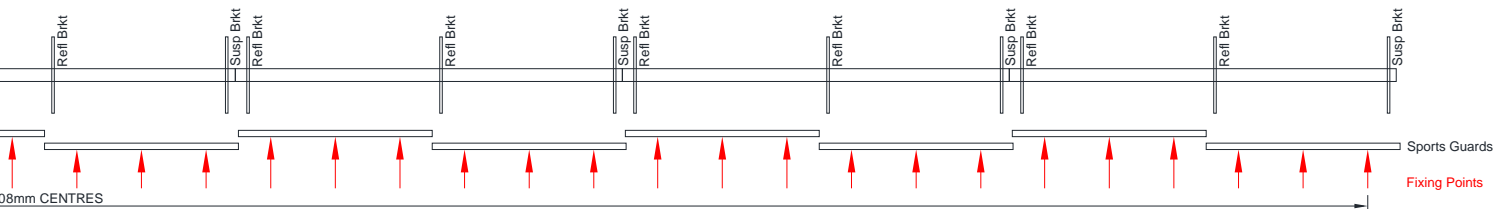
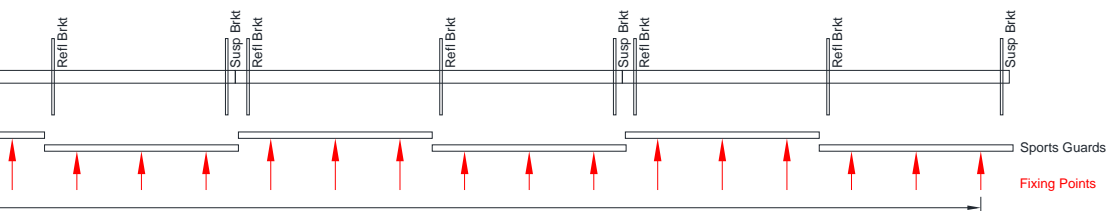
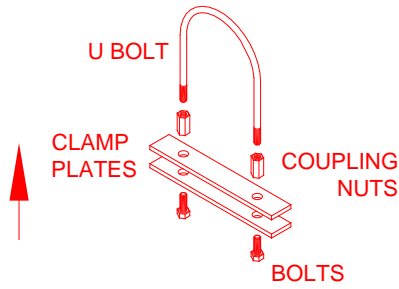

SUSPENSION BRACKET FIXINGS

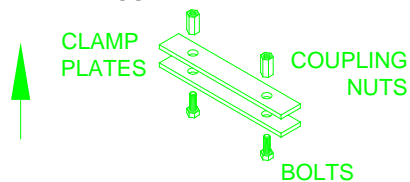

ADDITIONAL FIXINGS

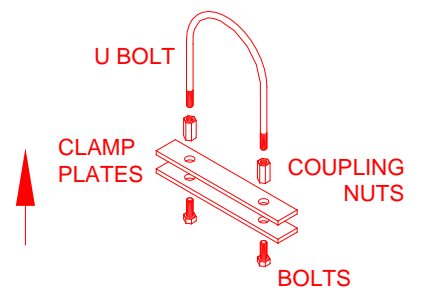



HEATING DIVISION
Hort Bridge
Ilminster, Somerset TA19 9PS
Tel: 01460 53535
Fax: 01460 52341



Every effort is made to ensure accuracy at time of going to press. However as part of continued product improvement, we reserve the right to alter specification without prior notice.