

TB135

Applies to models:

VPx



VPx

Gas Conversion Kit Instructions

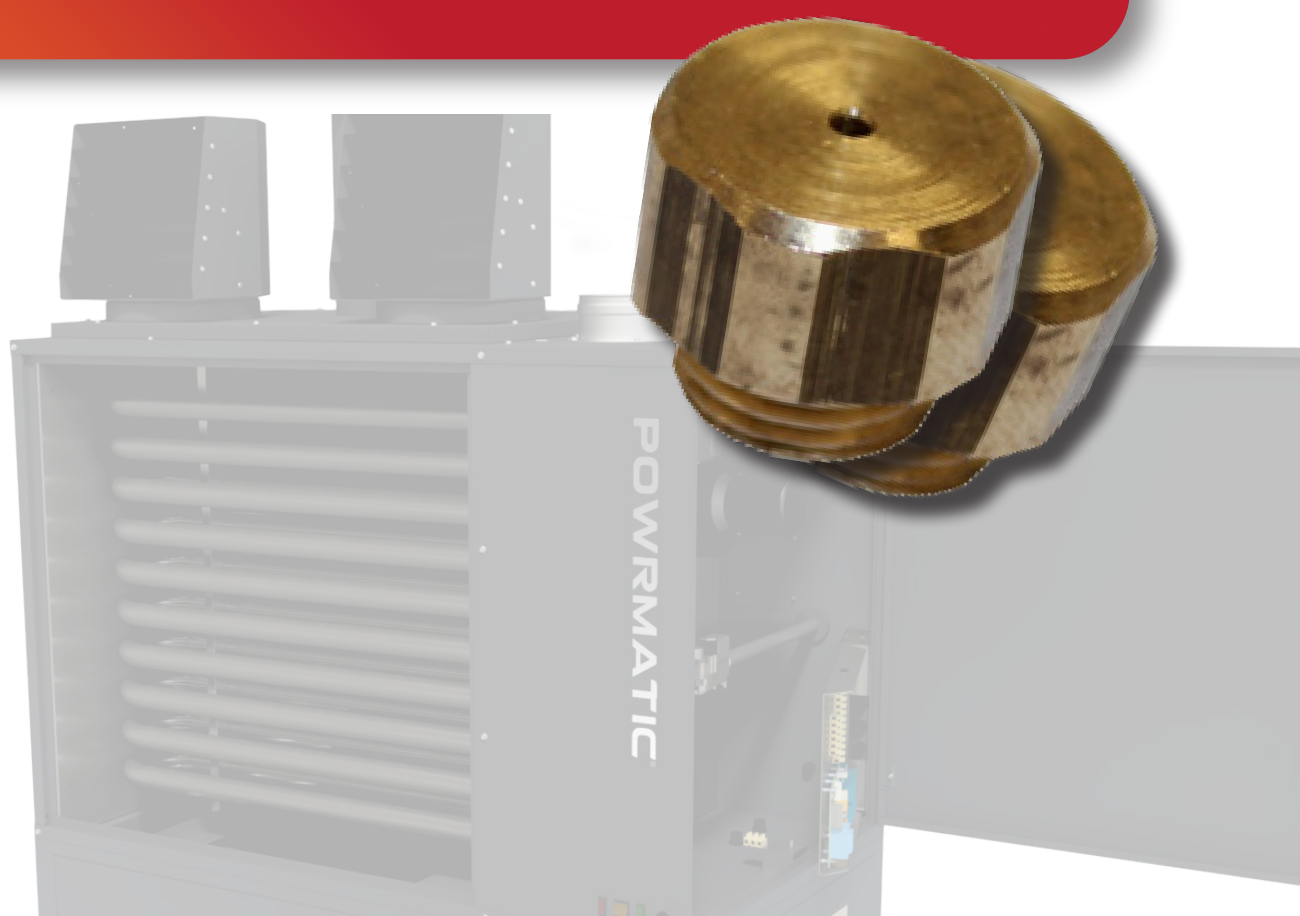

+44 (0) 1460 53535
info@powrmatic.co.uk

www.powrmatic.co.uk

General Information

Heater conversion between gases will require a change of burner injectors, alteration of burner pressure and re-commissioning of the heater.

All gas valves used on the VPx range have

pressure regulators that may be set to operate on natural gas or propane (LPG).

These assembly instructions describe the parts required and procedures to be carried out when converting this heater

Parts & Tools required



Drill plus bits



Flat head screwdriver



PoziDrive screwdriver



Electrical screwdriver



Spanner Set

	Propane (LPG) Conversion Kit				Natural Gas Conversion Kit			
MODEL	Conversion Kit part number	Burner Injector	Washers	Labels	Conversion Kit part number	Burner Injector	Washers	Labels
VPx35	VPx35LPG	7	7	3	VPx35NG	7	7	3
VPx50	VPx50LPG	10	10	3	VPx50NG	10	10	3
VPx70	VPx75LPG	10	10	3	VPx75NG	10	10	3
VPx90	VPx90LPG	8	8	3	VPx90NG	8	8	3
VPx120	VPx120LPG	10	10	3	VPx120NG	10	10	3
VPx140	VPx140LPG	12	12	3	VPx140NG	12	12	3

Gas Safety (Installation & Use) (Amendment) Regulations



It is law that all gas appliances are installed, adjusted and, if necessary, converted by qualified persons* in accordance with the current issue of the above regulations. Failure to install appliances correctly can lead to prosecution. It is in your own interests and that of safety to ensure that the law is complied with.

* A gas safe registered Engineer.



Ensure that the gas inlet pressure to the heater is correct for the new gas, and that the gas supply has been purged of the old gas. (Refer to tables opposite for new gas inlet pressures.)



WARNING: Always switch off and disconnect electricity supply and close service valve before carrying out any servicing or replacement of failed components.

1. Ensure that the gas service valve is turned OFF.

1.1 Remove rectification probe screw and withdraw.



1.2 Remove spark electrode screw and withdraw.



1.3 Remove the electrical plug connections from the top of the gas valve.



2. Remove the burner heat shield, 3 screws.



3. Release the outlet connection flange from the gas valve by removing the four screws.

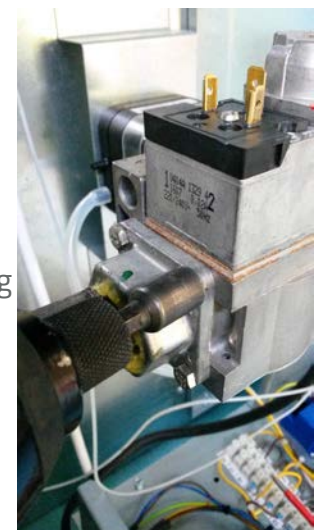

4. Remove two fixing screws securing the burner assembly to the bulkhead.

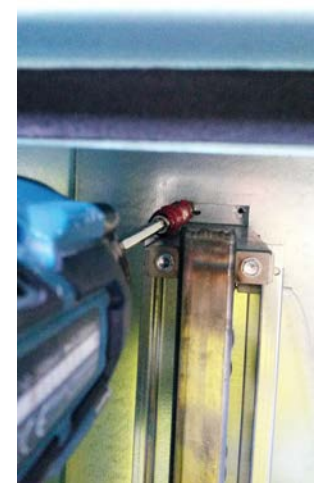

Procedure

5. Disengage from tab.



8. Remove the main burner injectors and washers.



6. Lift out burner assembly



9. Replace with the new injectors/washers for the new gas ensuring a gas tight seal.

10. Refit all other components in reverse order.

7. Remove the manifold by removing the four screws securing it to the burner assembly.



Commissioning and Testing

Adjustments

Conversion is carried out by adjusting the burner pressures to the values shown in the tables at the rear of this document.

High/Low Regulation

1. Set external controls to ensure the main burner is off. Open the side access panel.

Connect a pressure gauge to the burner pressure test point on the gas valve.

Lever off the plastic cover from the High/Low regulator.

2. Set external controls to turn on the main burner and maintain high fire. Adjust the burner gas pressure to the values shown in the tables at the rear of this document. In addition it is advisable to check the gas rate using the gas meter dial pointer ensuring that no other appliances supplied through the meter are in operation. Repeat with the external controls set to maintain low fire.

For actual valve adjustment, follow the specific valve type detailed on the next pages.



Note: High fire setting must be adjusted first after which the low fire setting can be set. Any adjustment of the high fire setting alters the minimum setting.

Sigma 843 Adjustment

Maximum Setting.

With the controls set to high fire, use an adjustable or 10mm spanner to screw the adjustment nut (C) in to increase and out to decrease, until the required pressure is obtained. Turn the burner On and OFF several times to check the pressure setting and then turn off.

Minimum Setting.

Disconnect electrical connection to the regulator and turn the burner back on and wait until the burner pressure has stabilised. Keeping the nut (C) stationary, use a 6 x 1 screwdriver to turn the slotted adjustment screw (D) clockwise to increase and counter-clockwise to decrease, until the required pressure is obtained. Reconnect high/low regulator and check high fire pressure. Repeat both steps if necessary and then replace cover cap

5. Turn off the main burner, disconnect the pressure gauge and replace the sealing screw. Turn on the main burner and test for gas soundness around pressure test joint using a leak detection fluid. Replace access panel.

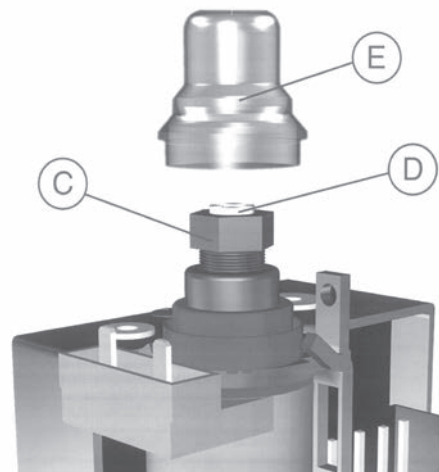

Honeywell High/Low Adjustment

Maximum Setting

With the controls set to high fire, use an adjustable or 8mm spanner to turn the adjustment screw, clockwise to increase and counter-clockwise to decrease, until the required pressure is obtained. Turn the burner On and OFF several times to check the pressure setting and then turn off.

Minimum Setting

Disconnect electrical connection to the regulator and turn the burner back on and wait until the burner pressure has stabilised. Use a

Commissioning and Testing

screwdriver to turn the slotted adjustment screw clockwise to increase and counter-clockwise to decrease, until the required pressure is obtained. Reconnect high/low regulator and check high fire pressure. Repeat both steps if necessary and then replace cover cap.

5. Turn off the main burner, disconnect the pressure gauge and replace the sealing screw. Turn on the main burner and test for gas soundness around pressure test joint using a leak detection fluid. Replace access panel.

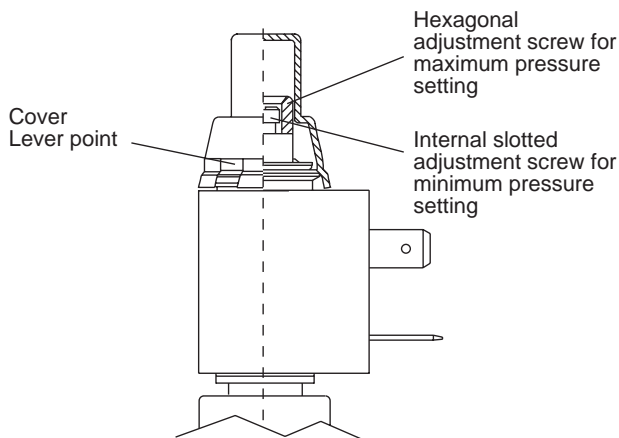

Honeywell Modulating Adjustment

1. Set external controls to ensure that the main burner is off. Open the side access panel. Connect a pressure gauge to the burner pressure test point on the gas valve.

2. Set external controls so as to turn on the main burner and maintain high fire. Compare the measured burner gas pressure to that stated on the data plate. In addition it is advisable to check the gas rate using the gas meter dial pointer ensuring that no other appliances supplied through the meter are in operation. Repeat with the external controls set to maintain low fire.

For actual valve adjustment, follow the specific valve type detailed on the next section.



Note: Minimum fire setting must be adjusted first after which the high fire setting can be set. Any adjustment of the minimum fire setting alters the maximum setting.

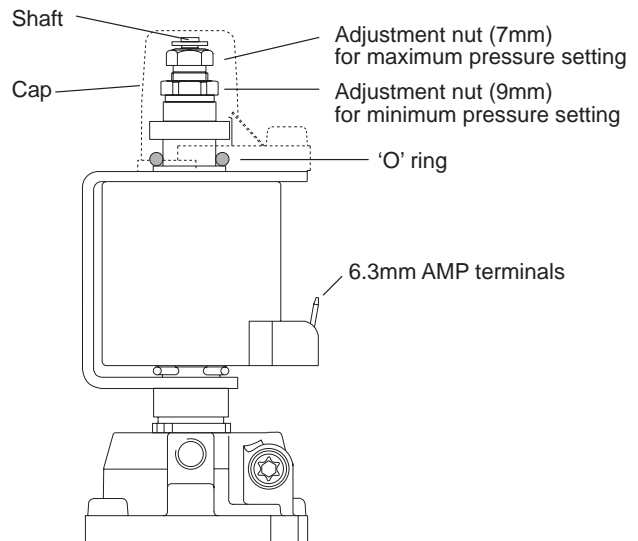

Minimum Setting.

Disconnect electrical connection of modulating regulator and turn burners back on and wait until the burner pressure has stabilized. Turn 9mm adjustment nut for low fire pressure clockwise to increase and counter-clockwise to decrease until the required pressure is obtained. Reconnect modulating regulator and check high fire pressure, readjust if necessary.

Maximum Setting.

Disconnect electrical connection of modulating regulator and turn burners back on and wait until the burner pressure has stabilised. Push shaft gently downwards to the maximum adjustment screw and hold there. Turn 7mm adjustment nut for high fire pressure, clockwise to increase and counter-clockwise to decrease, until the required pressure is obtained. Release shaft. Repeat both settings if necessary and then replace cover cap.

5. Turn off the main burner, disconnect the pressure gauge and replace the sealing screw. Turn on the main burner and test for gas soundness around pressure test joint using a leak detection fluid. Replace access panel.

Commissioning and Testing

On/Off Regulation

1. Set external controls to ensure the main burner is off. Open the side access panel. Connect a pressure gauge to the burner pressure test point on the gas valve.
2. Set external controls to turn on the main burner. Adjust the burner gas pressure to the values shown in the tables at the rear of this document. In addition it is advisable to check the gas rate using the gas meter dial pointer ensuring that no other appliances supplied through the meter are in operation.
3. To adjust burner pressure simply unscrew the aluminium cover using a flat head screwdriver and turn the adjustment screw clockwise to increase, anti-clockwise to decrease.

Final Checks

In addition to setting the burner pressures, it is advisable to check the gas rate using the gas meter dial pointer. Ensure that no other appliances supplied through the meter are in operation.

After setting the burner pressures, the CO/CO₂ content in the flue gases as well as the flue gas temperatures can be checked and recorded by sampling in the first section of flue fitted to the flue outlet of the unit.

Turn off the main burner and disconnect the pressure gauge and replace the sealing screw.

Turn on the main burner as above and test for gas soundness around pressure test joint using a leak detection fluid e.g. soap solution.

Remove the original data plate on the heater and replaced with new data badge supplied in the kit.

Two "change of gas" stickers are also supplied in the kit. Place one on the side of the gas valve and one on the outside of the heater adjacent to the gas pipe entry point.



Note*: Ensure the original data badge is removed and replaced with new data badge and "change of gas" stickers.

Model		35	50	70	90	120	140
Natural Gas G20							
High Fire CO ₂	%	8.02	8.6	9.15	7.50	8.40	8.72
FGT (nominal)	°C	150.5	152.0	158.6	132.0	153.0	128.0
Low Fire CO ₂	%	4.76	4.9	5.00	4.50	5.00	4.99
FGT (nominal)	°C	124.0	120.5	121.7	123.0	121.0	98.4
Propane G31							
High Fire CO ₂	%	9.8	10.0	9.60	7.50	9.40	9.31
FGT (nominal)	°C	153.0	178.0	158.9	143.0	148.0	126.6
Low Fire CO ₂	%	5.9	5.90	6.07	4.80	5.60	5.97
FGT (nominal)	°C	142.0	126.0	125.9	119.0	122.0	99.8

Commissioning and Testing

Natural Gas to Propane (LPG) Conversion Data

Nominal Inlet Pressure = 37mbar, Minimum Inlet Pressure = 37mbar						High Fire		Low Fire	
MODEL	Conversion Kit part number	Injectors				Burner Pressure	Gas Rate	Burner Pressure	Gas Rate
		No.	Size (mm)	Marked	Injector part number	mbar	m ³ /h	mbar	m ³ /h
VPx35	VPx35LPG	7	1.60	160	142401678	22.5	1.5	11.5	1.1
VPx50	VPx50LPG	10	1.6	160	142401678	24.2	2.3	12.2	1.6
VPx70	VPx75LPG	10	1.6	160	142401678	22.9	3.2	11.3	2.15
VPx90	VPx90LPG	8	2.26	580	142401667	13.5	4.0	7.2	2.91
VPx120	VPx120LPG	10	2.26	580	142401667	14.6	5.1	7.2	3.69
VPx140	VPx140LPG	12	2.26	580	142401667	13.4	5.9	6.4	4.11

Propane (LPG) to Natural Gas Conversion Data

Nominal Inlet Pressure = 20mbar, Minimum Inlet Pressure = 17.5mbar						High Fire		Low Fire	
MODEL	Conversion Kit part number	Injectors				Burner Pressure	Gas Rate	Burner Pressure	Gas Rate
		No.	Size (mm)	Marked	Injector part number	mbar	m ³ /h	mbar	m ³ /h
VPx35	VPx35NG	7	2.54	750	142401665	13.2	3.86	5.8	2.76
VPx50	VPx50NG	10	2.54	750	142401665	9.5	5.77	4.5	3.96
VPx70	VPx75NG	10	2.54	750	142401665	9.4	8.10	4.6	5.60
VPx90	VPx90NG	8	3.5	1500	142401666	6.0	10.32	3.0	7.58
VPx120	VPx120NG	10	3.5	1500	142401666	6.7	13.44	3.3	9.61
VPx140	VPx140NG	12	3.5	1500	142401666	6.2	15.45	2.9	10.7



HEATING DIVISION
Hort Bridge
Ilminster, Somerset TA19 9PS
Tel: 01460 53535
Fax: 01460 52341



Every effort is made to ensure accuracy at time of going to press. However as part of continued product improvement, we reserve the right to alter specification without prior notice.