

# Trade Data

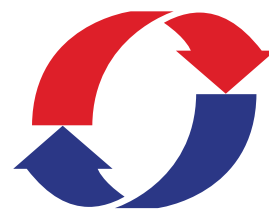

**powrmatic**

## NV

Gas Fired Unit Heaters

NV F Axial Fan - Crossflow and Downflow

NV C Centrifugal Fan

NV D Duct Heater

Heat Outputs from 10kW - 140kW

**2**  
PARTS & LABOUR  
YEARS  
GUARANTEE



Authorised User No. 00175

# Product Overview

## Benefits

### Installer Friendly

- Horizontal wall exit flue discharge option (no roof work)
- room sealed or fan assisted flue
- interchangeable top or rear flue/combustion air spigot positions
- axial fan versions configured for crossflow or downflow applications
- centrifugal fan and duct heater (no fan) options

### Caring For The Environment

- High Efficiency
- All models ECA Approved

### Peace Of Mind

- More Than Fifty Years Experience In Warm Air
- Two Year Parts And Labour Guarantee
- Ten Year Combustion Chamber/Heat Exchanger Warranty



## NV-C Unit

**Configuration** Powmatic NV gas fired unit heaters can be installed directly into the space to be heated in either axial fan crossflow or downflow configuration. Ducted or duct module applications may be satisfied using either the centrifugal fan or duct module variants. Heaters can be specified to provide on/off, high/low or modulated heat outputs.

**Efficiencies** Fuel usage and emissions are a key consideration within the NV design with all heaters having low NOx characteristics. Additionally, all heaters have efficiencies which meet or exceed the requirements of both current Building Regulations and the United Kingdom Enhanced Capital Allowance scheme.

**Cabinet** Of unitary construction, complete with a separate burner compartment accessed via a full width door and finished with hardwearing epoxy powder coat stove baked paint.

**Heat exchanger** Four pass tubular assembly manufactured from aluminised steel formed, swaged and expanded without recourse to stress inducing welding. 409 and 316 grade stainless steel options available.

**Burners** Multi burner in-shot carefully matched to each tube assembly and manifolded to a common gas valve and ignition system, itself complete with flame monitoring and safety controls and supplied ready for use with natural gas (G20). Alternative lpg propane (G31) firing available to order.

**Air Movement** Crossflow and downflow models are, dependent upon model, fitted with either single or multiple axial fan sets and discharge warmed air directly into the heated space via adjustable louvred horizontal grilles. Centrifugal fan models are fitted with the centrifugal fan housed within a fan plenum/silencer module.

**Controls** Heaters, as standard, are provided with high temperature limit protection as well as connections for both heat and where applicable, fan only operation. Heaters may be connected to our compatible environmental control stations which are themselves available in two options. The Powtrol control station provides a digital timeswitch with mechanical day and frost protection thermostats and switching options to enable 'fan only' operation for summer air movement. Alternatively heaters may be specified with the MC200 optimised entry code protected control (mandatory for ECA, high/low and modulating applications) which includes a digital time switch, electronic day and frost protection thermostats. Remote temperature sensor option available. Interconnecting wiring for all controls is the responsibility of the installer.

**Approvals** All Powmatic heaters are type tested to meet the stringent requirements of both the Gas Directive and CE accreditation.

## NV

Model			10	15	20	25	30	40	50	60	75	90	120	140		
<b>Output</b>	kW		10	15	20	25	30	40	50	60	75	90	120	140		
<b>Airflow</b>	Volume	NV F/ NV C	m³/s	0.26	0.39	0.52	0.65	0.78	1.04	1.30	1.56	1.95	2.34	3.12	3.64	
		NV D	min	m³/s	0.21	0.31	0.42	0.52	0.63	0.83	1.04	1.25	1.56	1.88	2.50	2.92
			max	m³/s	0.28	0.42	0.56	0.69	0.83	1.11	1.39	1.67	2.08	2.50	3.33	3.89
	Throw	NV F	m	6	6	9	11	13	13	19	22	24	26	29	30	
	Fan Static	NV C	Pa	147	145	177	143	250	236	205	250	260	200	284	285	
<b>Electrics</b>	Supply	Standard	V/PH/Hz	230/1/50												
		Optional	V/PH/Hz	415/3/50												
	NV F	Motor	kW	0.04	0.12	0.07	0.18	0.18	0.30	0.44	0.55	0.55	2 x 0.44	2 x 0.55	2 x 0.55	
		Start	amp	0.34	1.39	0.38	1.89	1.83	2.56	4.01	4.70	4.78	7.81	9.57	9.64	
		Run	amp	0.16	0.51	0.28	0.62	0.61	1.35	1.96	2.44	2.51	4.22	5.13	4.98	
	NV C	Motor	kW	0.37	0.37	0.37	0.37	1.10	1.10	1.10	1.50	1.50	2 x 1.10	2 x 1.50	2 x 1.50	
		Start	amp	8.30	8.10	7.80	8.20	14.70	14.00	16.00	24.50	24.50	28.40	42.50	39.80	
Run		amp	2.40	2.60	3.60	2.90	4.50	5.30	6.40	10.16	12.30	11.60	21.15	25.20		
<b>Fuel</b>	Connection	BSP/Rc	¾													
	Minimum Inlet Pressure	Nat Gas	mbar	17.5												
		LPG	mbar	37.0												
	Consumption	Nat Gas	m³/h	1.14	1.69	2.31	2.89	3.45	4.60	5.74	6.90	8.60	10.08	13.37	15.76	
LPG		m³/h	0.44	0.65	0.89	1.12	1.33	1.78	2.22	2.67	3.32	3.90	5.17	6.09		
<b>Mounting Height</b>	NV F Crossflow	Min	m	2.50					3.00							
		Max	m	3.00					5.00							
	NV F Downflow	Max	m	4.0	4.0	4.0	5.0	5.0	6.0	7.0	9.0	10.0	11.0	12.0	12.0	
<b>Overall Dimensions</b>	NV F	Height	mm	590	590	590	590	818	818	970	818	970	705	870	1035	
		Width	mm	750	1000	1000	1000	1000	1000	1000	1345	1345	2345	2345	2345	
		Depth	mm	820	820	820	845	845	845	845	845	845	845	845	845	
<b>Installation Clearances</b>	NV F	Top	mm	200												
		LH Side	mm	200												
		RH Side	mm	1000												
		Rear	mm	400												
<b>Flue</b>	Diameter	mm ø	80	80	80	80	100	100	100	130	130	130	130	130		
	Maximum Length	Flue Only	m	12												
Room Sealed		m	6													
<b>Combustion Air Spigot</b>		mm ø	80	80	80	80	100	100	100	130	130	130	130	130		
<b>Noise Level</b>		dB(A)	42	50	48	49	50	54	57	58	58	62	63	63		
<b>Nett Weight</b>	NV F	kg	53	54	68	89	89	93	114	130	150	188	260	260		
	NV C	kg	92	107	121	127	167	169	183	213	234	303	364	424		

### Notes –

Fuel consumption and output figures based upon nett calorific values as follows

Natural gas (G20) nett CV 34.02 MJ/m³

Propane (G31) nett CV 95.65 MJ/m³

Heaters have efficiency levels which meet with the minimum efficiency requirements of UK PartL2B Building Regulations

Heaters have efficiency levels which meet the criteria of the Enhanced Capital Allowance Scheme

Air handling data is assessed at room ambient conditions

Throw figures provide the distance to the point where the terminal velocity degrades to 0.25 m/s

Dimensions and clearance data in table above refer to NV F units only - for NV C and NV D data refer to the dimensions page and or the installation instructions

Noise levels are applicable to standard NV F models and are measured 5m from appliance and in free field conditions

Motor kW, run and start amps apply to standard electrical supply as stated. For optional data contact sales office

Connection of combustion air duct is not required for 'flue only' applications

Installer guidance notes on rear page

# Dimensions

## NV F - Axial Fan Crossflow and Downflow Units

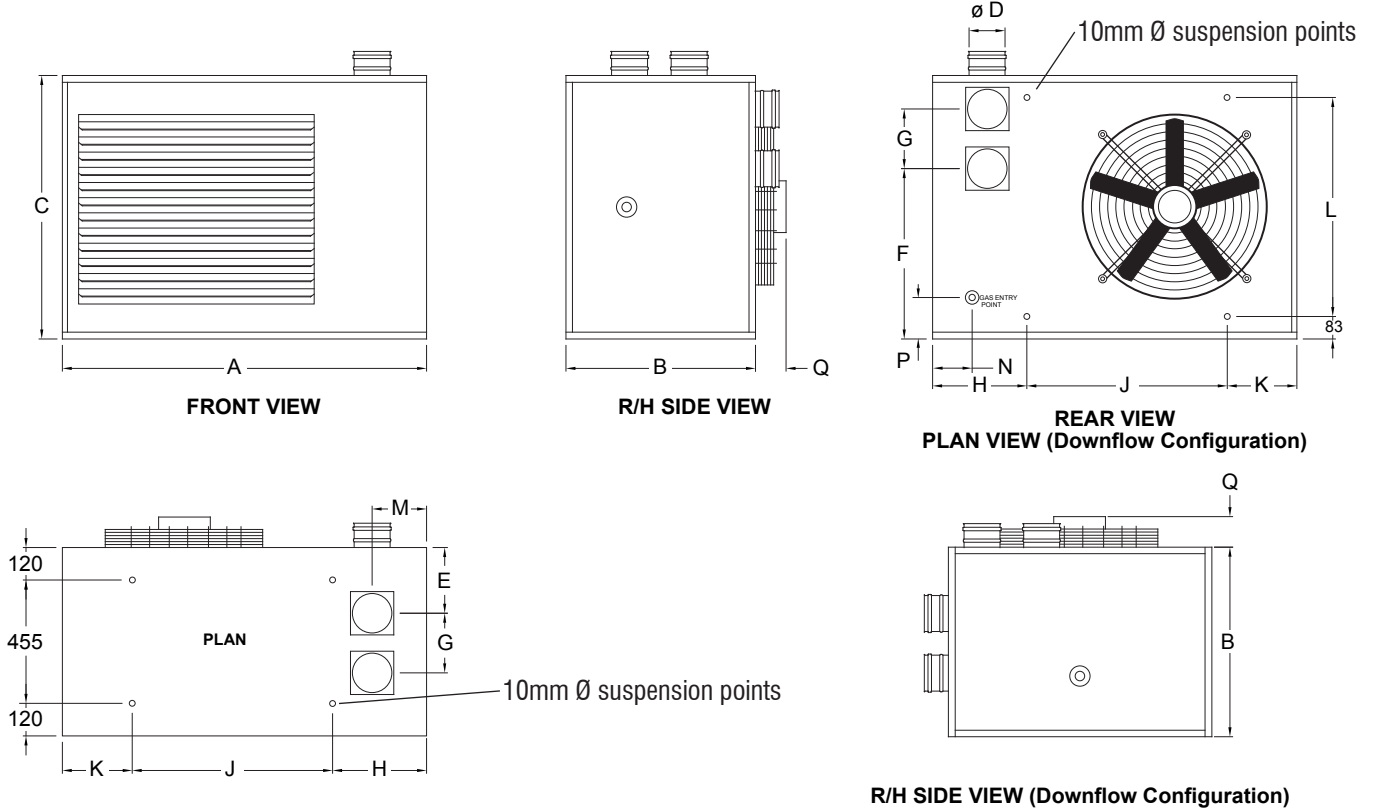

MODEL	10	15	20	25	30	40	50	60	75	90	120	140
A	750	1000	1000	1000	1000	1000	1000	1345	1345	2345	2345	2345
B	700	700	700	700	700	700	700	700	700	700	700	700
C	590	590	590	590	818	818	970	818	970	705	870	1035
D $\varnothing$	80	80	80	80	100	100	100	130	130	130	130	130
E	250	250	250	250	235	235	235	245	245	245	245	245
F	361	361	361	361	552	552	705	475	626	361	526	691
G	120	120	120	120	142	142	142	220	220	220	220	220
H	318	318	318	318	318	318	318	348	348	348	348	348
J	296	506	506	506	506	506	506	740	740	2 x 870	2 x 870	2 x 870
K	135	176	176	176	176	176	176	257	257	257	257	257
L	427	427	427	427	656	656	818	656	818	543	708	873
M	181	181	181	181	173	173	173	201	201	201	201	201
N	116	116	116	116	116	116	116	146	146	153	153	153
P	188	188	188	151	227	151	151	151	151	87.5	87.5	87.5
Q	120	120	120	145	145	145	145	145	145	145	145	145

## NV C Centrifugal Fan Units

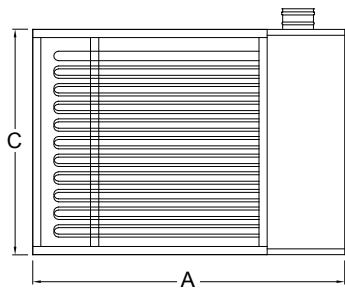

FRONT VIEW

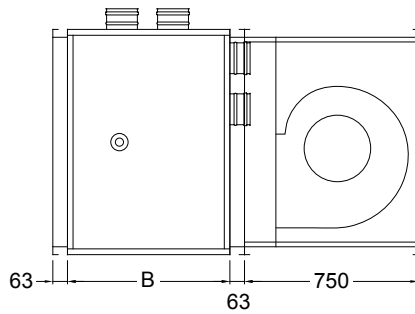

R/H SIDE VIEW

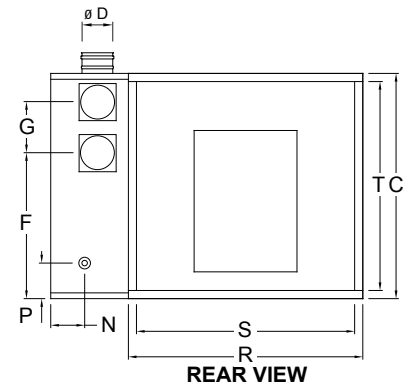

REAR VIEW

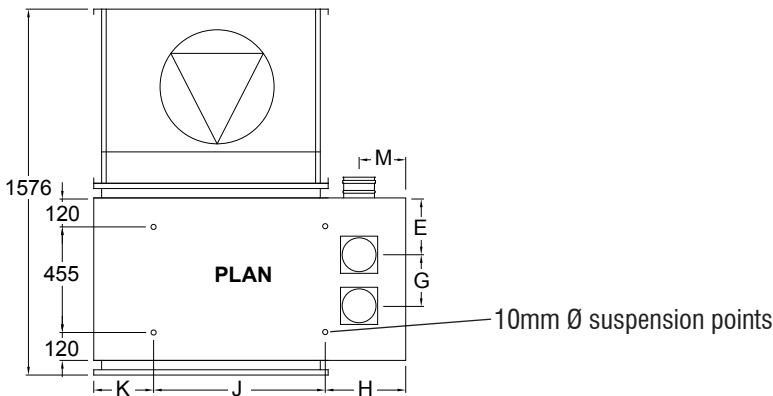

MODEL	10	15	20	25	30	40	50	60	75	90	120	140
A	750	1000	1000	1000	1000	1000	1000	1345	1345	2345	2345	2345
B	700	700	700	700	700	700	700	700	700	700	700	700
C	590	590	590	590	818	818	970	818	970	705	870	1035
D $\varnothing$	80	80	80	80	100	100	100	130	130	130	130	130
E	250	250	250	250	235	235	235	235	235	235	235	235
F	361	361	361	361	552	552	705	475	626	361	526	691
G	120	120	120	120	142	142	142	220	220	220	220	220
H	318	318	318	318	318	318	318	348	348	348	348	348
J	296	506	506	506	506	506	506	740	740	2 x 870	2 x 870	2 x 870
K	135	176	176	176	176	176	176	257	257	257	257	257
M	181	181	181	181	173	173	173	201	201	201	201	201
N	116	116	116	116	116	116	116	146	146	153	153	153
P	188	188	188	151	227	151	151	151	151	87.5	87.5	87.5
R	502	696	696	696	696	696	696	1010	1010	2014	2014	2014
S	432	626	626	626	626	626	626	940	940	1944	1944	1944
T	520	520	520	520	748	748	900	748	900	635	800	965

# Dimensions

## NV D Ducted Units

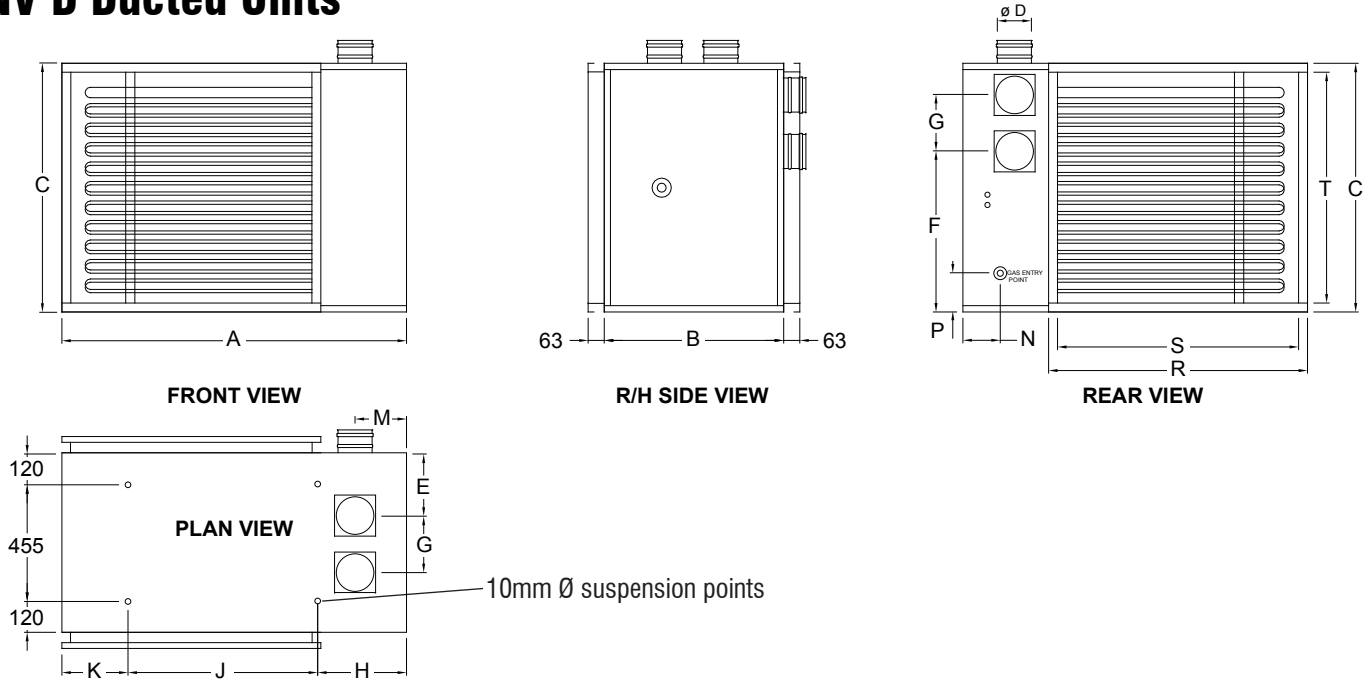

MODEL	10	15	20	25	30	40	50	60	75	90	120	140
<b>A</b>	750	1000	1000	1000	1000	1000	1000	1345	1345	2345	2345	2345
<b>B</b>	700	700	700	700	700	700	700	700	700	700	700	700
<b>C</b>	590	590	590	590	818	818	970	818	970	705	870	1035
<b>DØ</b>	80	80	80	80	100	100	100	130	130	130	130	130
<b>E</b>	250	250	250	250	235	235	235	235	235	235	235	235
<b>F</b>	361	361	361	361	552	552	705	475	626	361	526	691
<b>G</b>	120	120	120	120	142	142	142	220	220	220	220	220
<b>H</b>	318	318	318	318	318	318	318	348	348	348	348	348
<b>J</b>	296	506	506	506	506	506	506	740	740	2 x 870	2 x 870	2 x 870
<b>K</b>	135	176	176	176	176	176	176	257	257	257	257	257
<b>M</b>	181	181	181	181	173	173	173	201	201	201	201	201
<b>N</b>	116	116	116	116	116	116	116	146	146	153	153	153
<b>P</b>	188	188	188	151	227	151	151	151	151	87.5	87.5	87.5
<b>R</b>	502	696	696	696	696	696	696	1010	1010	2014	2014	2014
<b>S</b>	432	626	626	626	626	626	626	940	940	1944	1944	1944
<b>T</b>	520	520	520	520	748	748	900	748	900	635	800	965

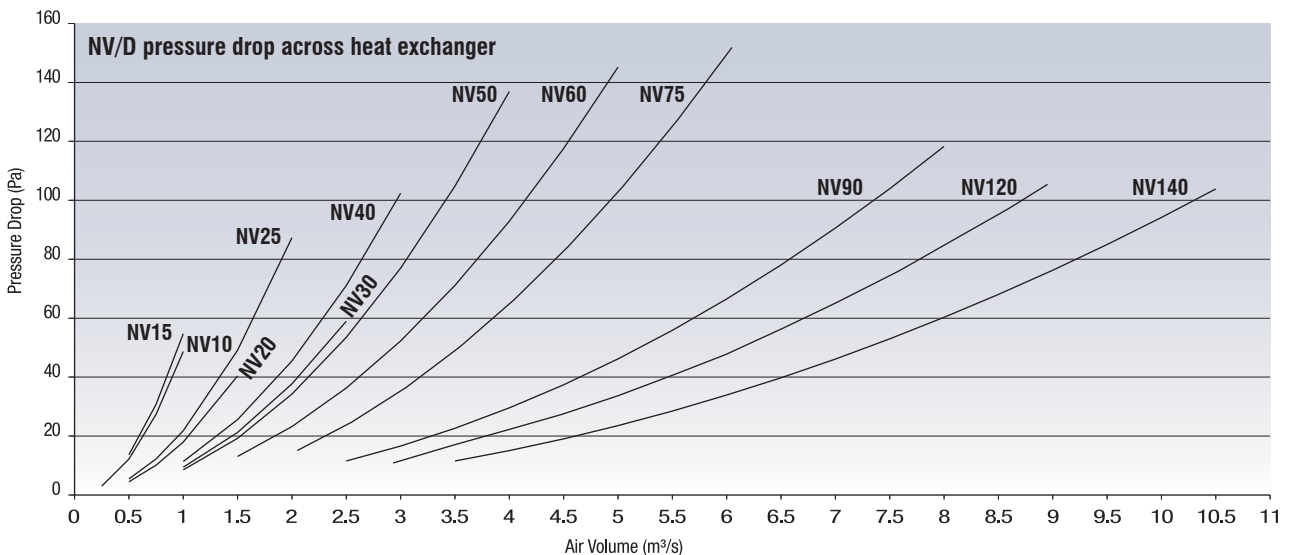

# Flue Systems

## Exhaust only system - horizontal

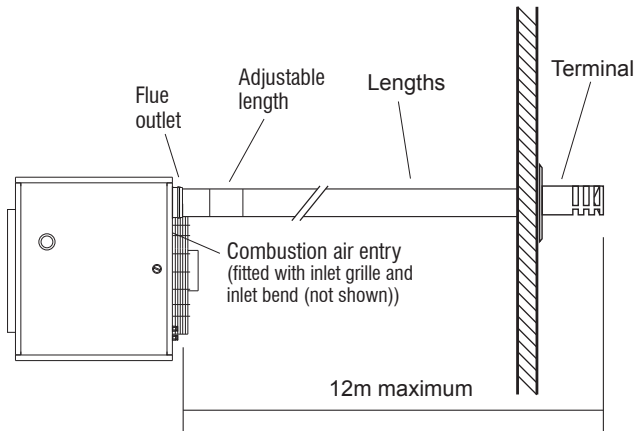

## Twin individual pipe system - horizontal

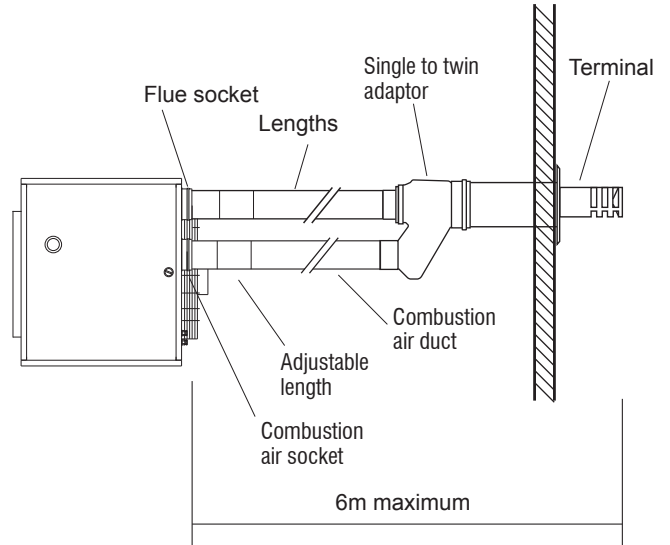

## Exhaust only system - vertical

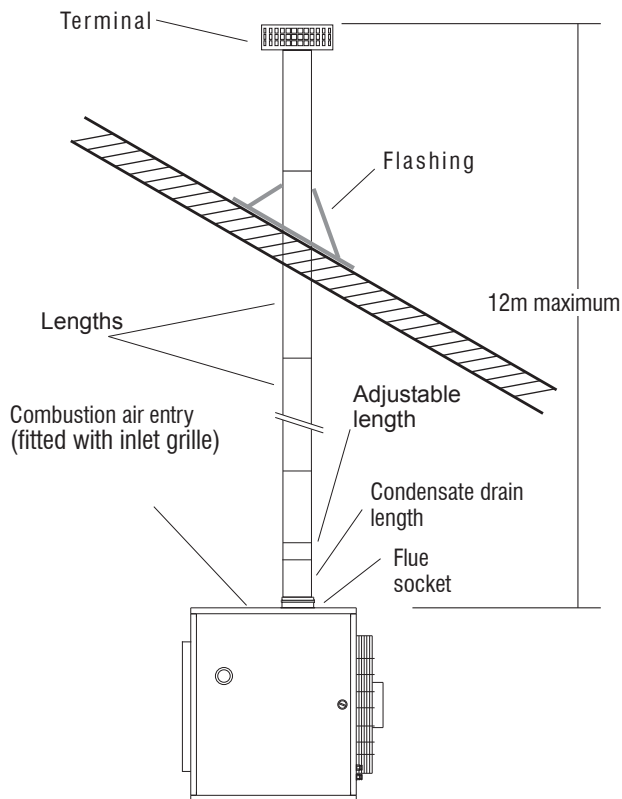

## Twin individual pipe system - vertical

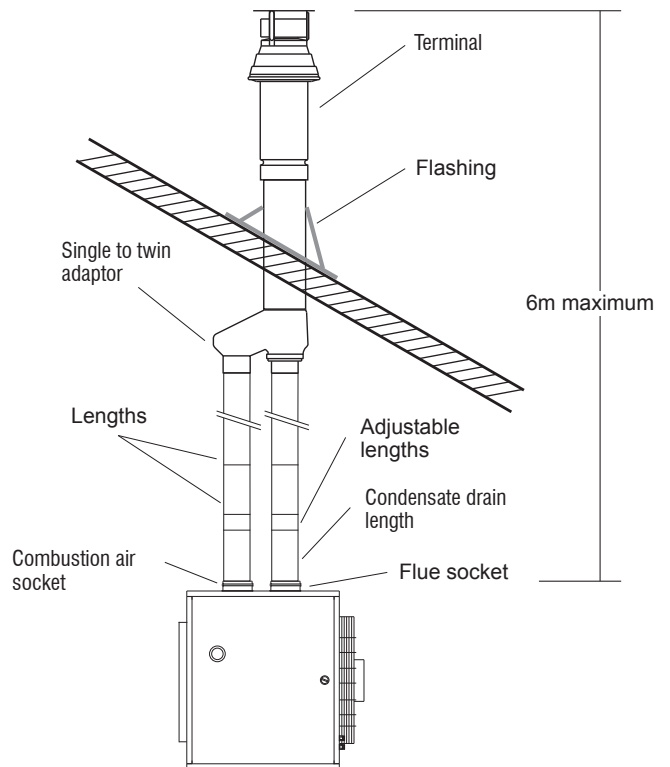

### Notes for all systems.

- i) Final overall length of adjustable length disconnection piece must be between 360 - 415mm.
- ii) 45° offsets may be used if required. Each set is equivalent to 0.5m of flue length.
- iii) Where NV heaters are used in clean environments it is permissible to take the combustion air directly from the heated space. The supplied mesh intake plate, must be fitted to the combustion air inlet on the rear of the heater.

# Installer Guide

**General** The following notes are provided as a help, however installers and operators should fully acquaint themselves with the more detailed guidance provided in the relevant installation manual. For copies of such manuals please consult our technical department or visit our website - [www.powrmatic.co.uk](http://www.powrmatic.co.uk)

**Standards** All Powrmatic NV heaters must be installed, commissioned and operated with due regard to appropriate regulations including but not limited to BS 6230 2005, relevant Codes of Practice, the possible requirements of Local Authorities, Fire Officers and insurers as well as Powrmatic's installation manual.

**Position & Location** Powrmatic NV heaters can be 'drop rod' suspended via purpose designed M10 suspension fixing points, attached to our optional wall support brackets or positioned on a level non-combustible base. In all cases it is important that all supporting structures have due regard to the relevant weight loadings.

Consideration should also be given to flue routes and points of exit, gas, electrical and control connections, the throw characteristics of the heater, issues of public access and in the instance of remote temperature sensors the where position need to be representative of the zone temperature to which they refer.

Heaters should not be installed in hazardous areas or areas where there is a foreseeable risk of flammable or corrosion inducing particles, gases or vapours being drawn into the combustion air or main fan circuits.

Areas where special consideration or advice may be required could include but is not limited to -

- where de-greasing solvents are present, even in minute concentrations
- where paint spraying is carried out
- where styrenes or other laminating products are used
- where airborne silicone is present
- where petrol engined vehicles are stored or maintained
- where dust is present (ie wood working or joinery shops)
- where high levels of extract persist

Installation in such areas may be possible under specific conditions. Please consult our technical department for further information.



Hort Bridge  
Ilminster  
Somerset

TA19 9PS

United Kingdom

Tel: +44 (0)1460 53535

Fax: +44 (0)1460 52341

Email [info@powrmatic.co.uk](mailto:info@powrmatic.co.uk)

[www.powrmatic.co.uk](http://www.powrmatic.co.uk)

**Plant Room or Enclosure Locations** It is possible to install centrifugal fan or duct module variants of the nv heater within plant rooms or enclosures however specific requirements may be required. Such requirements cover the provision of positive ductwork connections as well as ventilation for combustion air and general plant room or enclosure ventilation. It is recommended that you consult with our technical department or the installation manual prior to installation.

**Combustion Air & General Ventilation** Within the United Kingdom mandatory regulations apply concerning the provision of combustion air and general heater ventilation.

Where a heater is installed in room sealed mode (ie where both the flue exit and combustion air are positively connected to atmosphere) then there is no specific requirement for combustion air ventilation. However, depending upon location, provision for general ventilation may still be a necessity.

If the heater is installed in flue only mode and directly within the heated space and where that heated space has a natural ventilation rate greater than 0.5 air changes per hour then combustion air and general heater ventilation is probably not required. If the heated space has a natural ventilation rate of less than 0.5 air changes per hour then either natural ventilator openings or mechanical ventilation will be required. Please consult the installation manual for further details.

**Installation Clearances** Particular clearances may be necessary for the correct and safe function of the heater as well as for maintenance purposes. Such clearances are confirmed in the relevant installation manual.

**Flue** Powrmatic NV heaters can be installed in either room sealed or flue only mode. Each heater requires a separate flue and/or combustion air intake system of the appropriate size and type. Installers are reminded that type approval has been granted for these appliances on the basis that they are fitted with Powrmatic NV flue systems. Maximum lengths apply and should be strictly observed.

Systems may be installed in either the horizontal or vertical plane. In either case the number of bends kept to a minimum and regard must be given to the reduction in permissible length with the addition of each bend.

The flue must be adequately supported and terminated with the approved terminal assembly, with due regard to the point of exit and it's proximity to any windows, doors or ventilation intakes etc

**Pipework** Care should be taken when sizing pipework to ensure that minimum gas pressures are not compromised under dynamic load conditions. Isolating valves and service unions should be provided for each heater and pipework installed with due regard for relevant standards and Codes of Practice.

## Guarantee

Powrmatic heaters are provided with a comprehensive guarantee covering both the heater and the heat exchanger. For United Kingdom sales the heater has the benefit of a two year parts and labour guarantee whilst the heat exchanger assembly has a **ten year** time related warranty. All guarantees are subject to terms and conditions.

Powrmatic pursues a policy of continuous improvement in both design and performance of its products and therefore reserves the right to change, amend or vary specifications without notice. Whilst the details contained herein are believed to be correct they do not form the basis of any contract and interested parties should contact the Company to confirm whether any material alterations have been made since publication of this brochure.

