

Trade Data

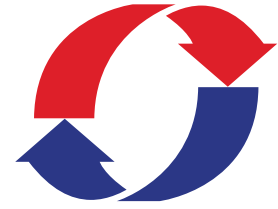

powrmatic

NVS

Fully Condensing Gas Fired Unit Heaters

NVS F Axial Fan - Crossflow

NVS C Centrifugal Fan

NVS D Duct Heater

Heat Outputs from 30kW - 140kW

Net Efficiencies up to 104%

2 YEARS
PARTS & LABOUR
GUARANTEE



Authorised User No. 00175

Product Overview

Benefits

Installer Friendly

- Horizontal wall exit flue discharge option (no roof work)
- room sealed or fan assisted flue
- axial fan versions configured for crossflow applications
- centrifugal fan and duct heater (no fan) options

Caring For The Environment

- High Efficiency - Fully Condensing
- All models ECA Approved

Peace Of Mind

- More Than Fifty Years Experience In Warm Air
- Two Year Parts And Labour Guarantee
- Ten Year Combustion Chamber/Heat Exchanger Warranty



Rear view of unit showing condense drain point



Rear view of unit showing aluminium secondary heat exchanger

Configuration Powrmatic NVS gas fired unit heaters can be installed directly into the space to be heated. Ducted or duct module applications may be satisfied using either the centrifugal fan or duct module variants. Heaters can be specified to provide on/off, high/low or modulated heat outputs.

Efficiencies Fuel usage is reduced, compared with the NV range, due to the higher efficiency that NVS units have. Emissions are also a key consideration within the NVS design with all heaters having low NOx characteristics. All heaters have efficiencies which meet or exceed the requirements of both current Building Regulations and the United Kingdom Enhanced Capital Allowance scheme.

Cabinet Of unitary construction, complete with a separate burner compartment accessed via a full width door and finished with hardwearing epoxy powder coat stove baked paint.

Heat exchanger Four pass primary tubular assembly manufactured from aluminised steel formed, swaged and expanded without recourse to stress inducing welding. 409 and 316 grade stainless steel options available. Two pass secondary assembly manufactured from extruded aluminium.

Burners Multi burner in-shot carefully matched to each tube assembly and manifolded to a common gas valve and ignition system, itself complete with flame monitoring and safety controls and supplied ready for use with natural gas (G20). Alternative lpg propane (G31) firing available to order.

Air Movement Crossflow models are, dependent upon model, fitted with either single or multiple axial fan sets and discharge warmed air directly into the heated space via adjustable louvred horizontal grilles. Centrifugal fan models are fitted with the centrifugal fan housed within a fan plenum/silencer module.

Controls Heaters, as standard, are provided with high temperature limit protection as well as connections for both heat and where applicable, fan only operation. Heaters may be connected to our compatible environmental control stations which are themselves available in two options.

The MC200, a tamperproof digital control that features optimised start and stop (mandatory for ECA, high/low and modulating applications) which includes a digital time switch, electronic day thermostat and frost protection thermostat. Remote temperature sensor option available.

Alternatively heaters may be specified with the Powtrol control station which provides a digital timeswitch with mechanical day and frost protection thermostats and switching options to enable 'fan only' operation for summer air movement. Interconnecting wiring for all controls is the responsibility of the installer.

Approvals All Powrmatic heaters are type tested to meet the stringent requirements of both the Gas Directive and CE accreditation.

NV

Model			30	60	90	140		
Output			kW	30	60	90	140	
Airflow	Volume	NVS F/ NV C	m³/s	0.78	1.56	2.34	3.64	
		NVS D	min	m³/s	0.63	1.25	1.88	2.92
			max	m³/s	0.83	1.67	2.50	3.89
	Throw	NVS F	m	13	22	26	30	
	Fan Static	NVS C	Pa	250	250	200	285	
Electrics	Supply	Standard	V/PH/Hz	230/1/50				
		Optional	V/PH/Hz	415/3/50				
	NVS F	Motor	kW	0.18	0.55	2 x 0.44	2 x 0.55	
		Start	amp	1.83	4.70	7.81	9.64	
		Run	amp	0.61	2.44	4.22	4.98	
	NVS C	Motor	kW	1.10	1.50	2 x 1.10	2 x 1.50	
		Start	amp	14.70	24.50	28.40	39.80	
		Run	amp	4.50	10.16	11.60	25.20	
Fuel	Connection		BSP/Rc	¾				
	Minimum Inlet Pressure	Nat Gas	mbar	17.5				
		LPG	mbar	37.0				
	Consumption	Nat Gas	m³/h	3.14	6.26	9.17	14.59	
		LPG	m³/h	1.21	2.42	3.55	5.64	
Mounting Height	NVS F Crossflow	Min	m	2.50	3.00			
		Max	m	3.00	5.00			
Overall Dimensions	NVS F	Height	mm	818	818	705	1035	
		Width	mm	1050	1345	2345	2345	
		Depth	mm	1176	1176	1176	1176	
Installation Clearances	NVS F	Top	mm	200				
		LH Side	mm	200				
		RH Side	mm	1000				
		Rear	mm	400				
Condensate	Natural Gas		l/h	2.3	3.4	6.0	8.8	
	Propane		l/h	1.2	1.7	3.0	4.4	
Flue	Diameter		mm ø	100	130	130	130	
	Maximum Length	Flue Only	m	12				
Room Sealed		m	6					
Combustion Air Spigot			mm ø	100	130	130	130	
Noise Level			dB(A)	50	58	62	63	
Nett Weight	NV F		kg	124	176.5	245	350	
	NV C		kg	193.5	253	382	501	

Notes –

Fuel consumption and output figures based upon nett calorific values as follows

Natural gas (G20) nett CV 34.02 MJ/m³

Propane (G31) nett CV 95.65 MJ/m³

Heaters have efficiency levels which meet with the minimum efficiency requirements of UK Part L2B Building Regulations

Heaters have efficiency levels which meet the criteria of the Enhanced Capital Allowance Scheme

Air handling data is assessed at room ambient conditions

Throw figures provide the distance to the point where the terminal velocity degrades to 0.25 m/s

Dimensions and clearance data in table above refer to NV F units only - for NV C and NV D data refer to the dimensions page and or the installation instructions

Condensate rates are approximate and for when heaters are working at maximum output

Noise levels are applicable to standard NV F models and are measured 5m from appliance and in free field conditions

Motor kW, run and start amps apply to standard electrical supply as stated. For optional data contact sales office

Connection of combustion air duct is not required for 'flue only' applications

Installer guidance notes on rear page

Dimensions

NV F - Axial Fan Crossflow Units

NVS 30 & 60

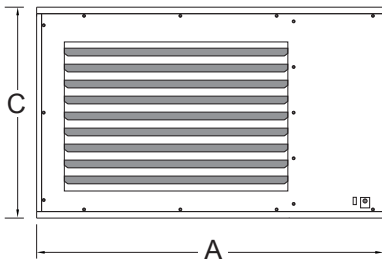

FRONT VIEW

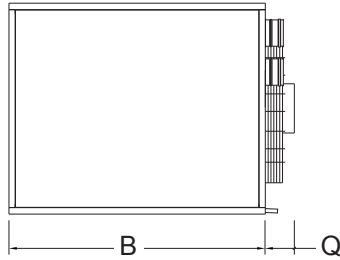

SIDE VIEW

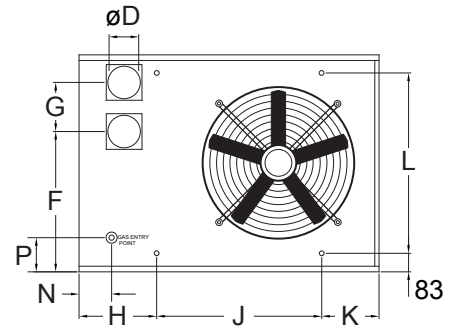

REAR VIEW

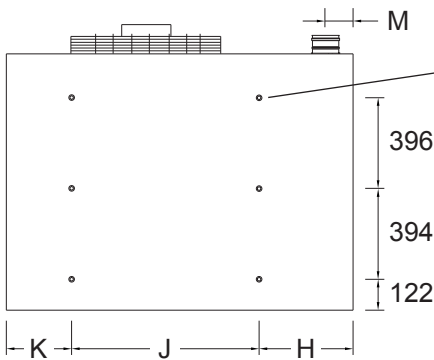

PLAN VIEW

10mm Ø suspension points

NVS 90 & 140

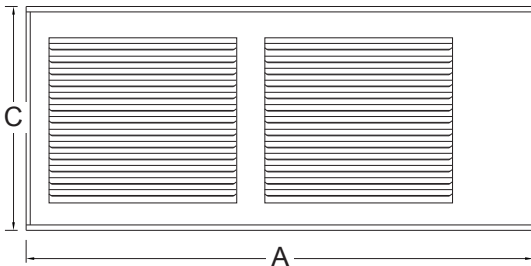

FRONT VIEW

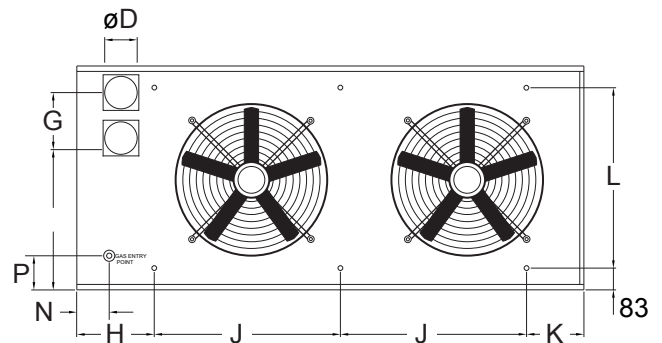

REAR VIEW

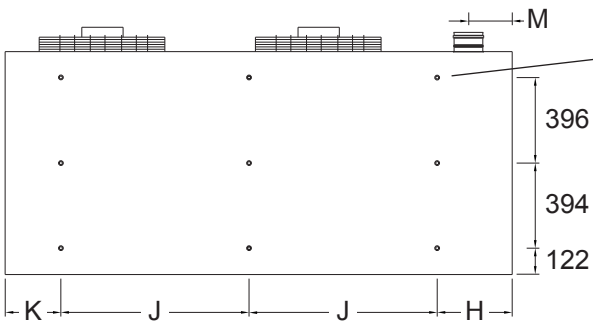

PLAN VIEW

10mm Ø suspension points

Model	A	B	C	D	F	G	H	J	K	M	O	P	Q
NVS30	1050	1031	818	100	552	142	347	445	258	173	189	227	145
NVS60	1345	1031	818	130	475	220	347	740	258	201	189	151	145
NVS90	2345	1031	705	130	220	220	347	870	258	201	189	87.5	145
NVS140	2345	1031	1035	130	220	220	347	870	258	201	151	87.5	145

NVS C Centrifugal Fan Units

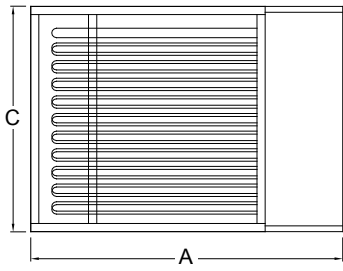

FRONT VIEW

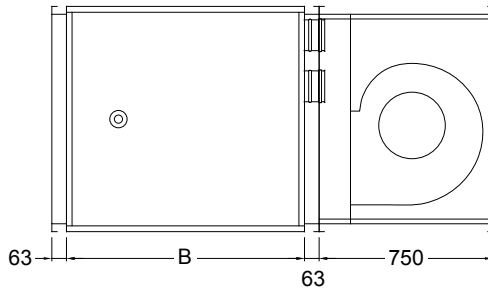

R/H SIDE VIEW

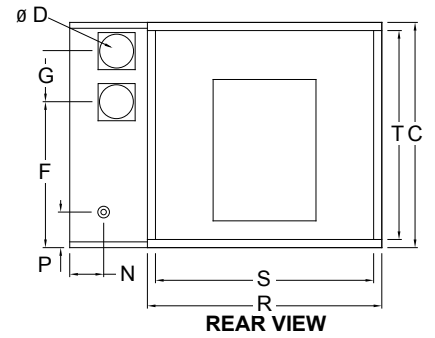

REAR VIEW

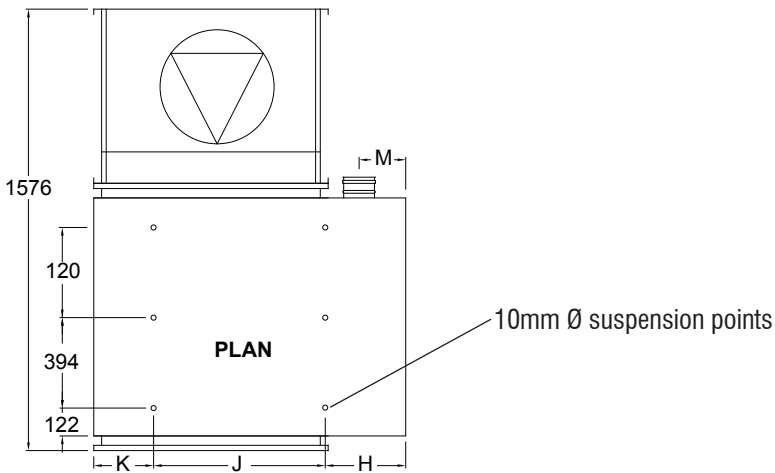

PLAN

10mm Ø suspension points

Model	A	B	C	D	F	G	H	J	K	M	O	P	R	S	T
NVS30	1050	1031	818	100	552	142	347	445	258	173	189	227	696	626	748
NVS60	1345	1031	818	130	475	220	347	740	258	201	189	151	1010	940	748
NVS90	2345	1031	705	130	220	220	347	870	258	201	189	87.5	2014	1944	635
NVS140	2345	1031	1035	130	220	220	347	870	258	201	151	87.5	2014	1944	965

Dimensions

NV D Ducted Units

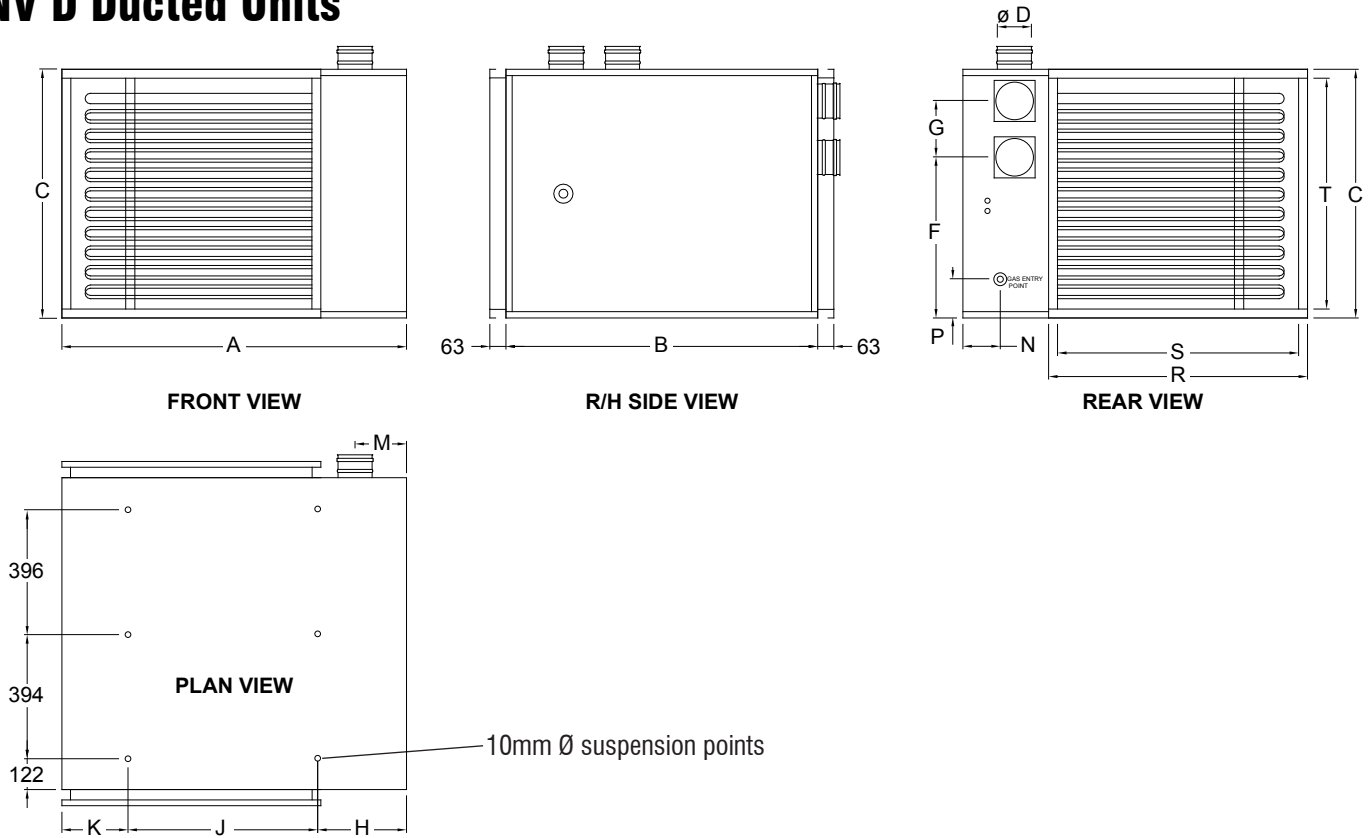

Model	A	B	C	D	F	G	H	J	K	M	O	P	Q
NVS30	1050	1031	818	100	552	142	347	445	258	173	189	227	145
NVS60	1345	1031	818	130	475	220	347	740	258	201	189	151	145
NVS90	2345	1031	705	130	220	220	347	870	258	201	189	87.5	145
NVS140	2345	1031	1035	130	220	220	347	870	258	201	151	87.5	145

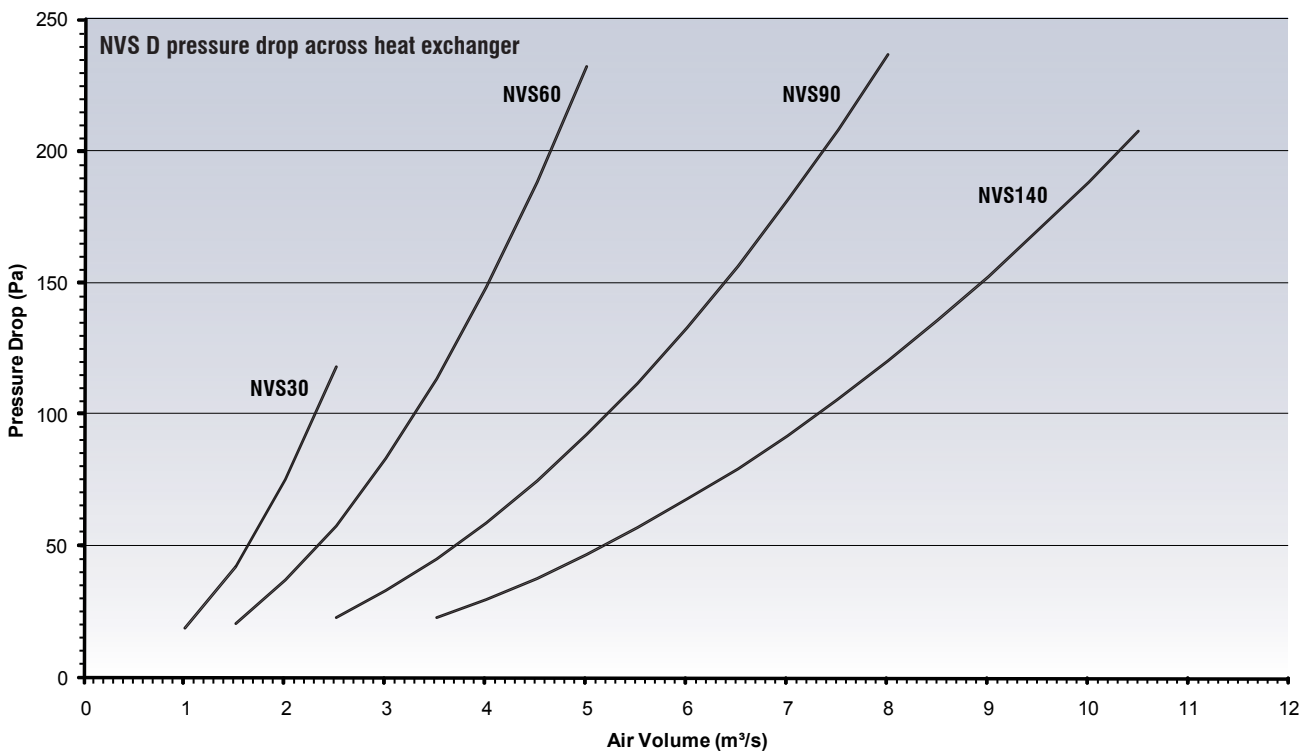

Flue Systems

Exhaust only system - horizontal

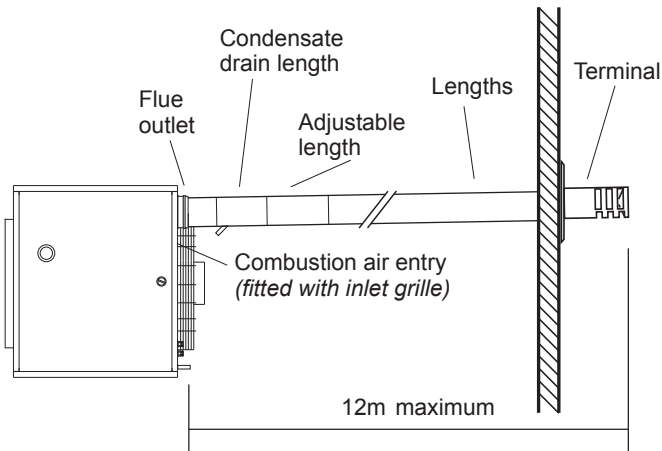

Twin individual pipe system - horizontal

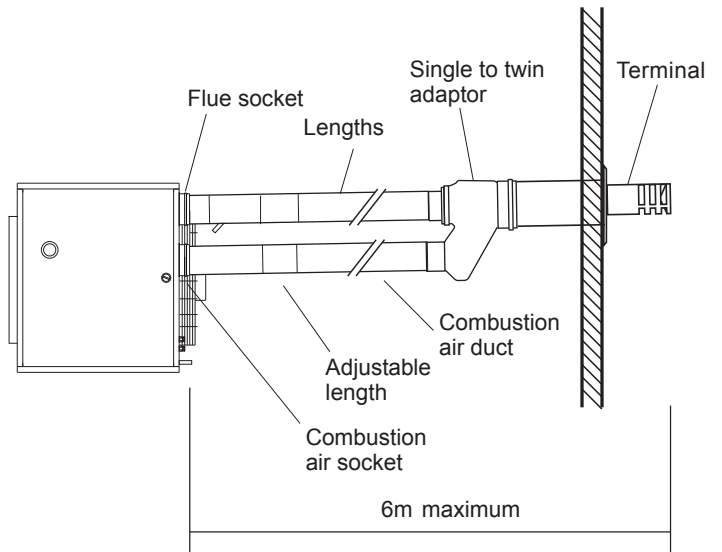

Exhaust only system - vertical

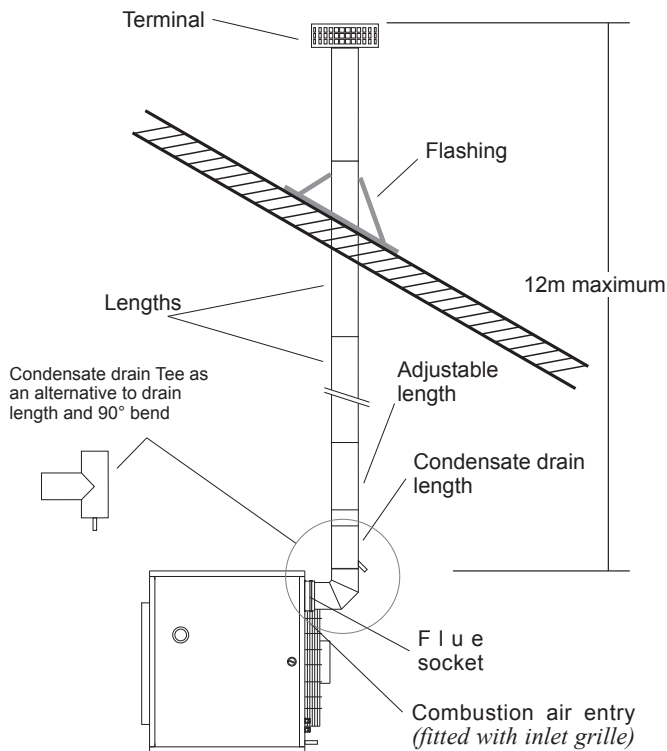

Twin individual pipe system - vertical

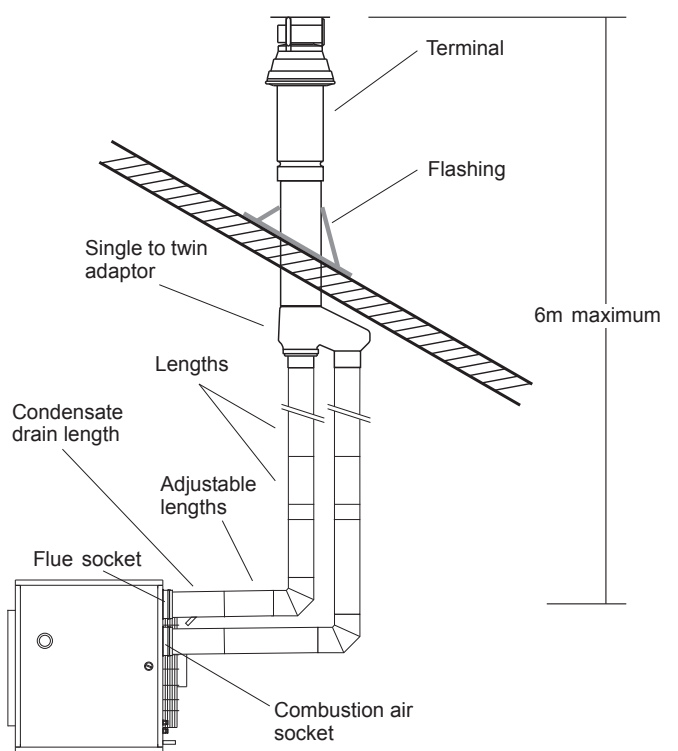

Notes for all systems.

- i) Final overall length of adjustable length disconnection piece must be between 360 - 415mm.
- ii) 45° offsets may be used if required. Each set is equivalent to 0.5m of flue length.
- iii) Where NVS heaters are used in clean environments it is permissible to take the combustion air directly from the heated space. The supplied mesh intake plate, must be fitted to the combustion air inlet on the rear of the heater.

Installer Guide

General The following notes are provided as a help, however installers and operators should fully acquaint themselves with the more detailed guidance provided in the relevant installation manual. For copies of such manuals please consult our technical department or visit our website - www.powrmatic.co.uk

Standards All Powrmatic NVS heaters must be installed, commissioned and operated with due regard to appropriate regulations including but not limited to BS 6230 2005, relevant Codes of Practice, the possible requirements of Local Authorities, Fire Officers and insurers as well as Powrmatic's installation manual.

Position & Location Powrmatic NVS heaters can be 'drop rod' suspended via purpose designed M10 suspension fixing points, attached to our optional wall support brackets or positioned on a level non-combustible base. In all cases it is important that all supporting structures have due regard to the relevant weight loadings.

Consideration should also be given to flue routes and points of exit, gas, electrical and control connections, the throw characteristics of the heater, the routing of the condensate drain pipe, disposal of the condensate, issues of public access and in the instance of remote temperature sensors the where position need to be representative of the zone temperature to which they refer.

Heaters should not be installed in hazardous areas or areas where there is a foreseeable risk of flammable or corrosion inducing particles, gases or vapours being drawn into the combustion air or main fan circuits.

Areas where special consideration or advice may be required could include but is not limited to -

- where de-greasing solvents are present, even in minute concentrations
- where paint spraying is carried out
- where styrenes or other laminating products are used
- where airborne silicone is present
- where petrol engined vehicles are stored or maintained
- where dust is present (ie wood working or joinery shops)
- where high levels of extract persist

Installation in such areas may be possible under specific conditions. Please consult our technical department for further information.



Hort Bridge
Ilminster
Somerset
TA19 9PS
United Kingdom
Tel: +44 (0)1460 53535
Fax: +44 (0)1460 52341
Email info@powrmatic.co.uk
www.powrmatic.co.uk

Plant Room or Enclosure Locations It is possible to install centrifugal fan or duct module variants of the NVS heater within plant rooms or enclosures however specific requirements may be required. Such requirements cover the provision of positive ductwork connections as well as ventilation for combustion air and general plant room or enclosure ventilation. It is recommended that you consult with our technical department or the installation manual prior to installation.

Combustion Air & General Ventilation Within the United Kingdom mandatory regulations apply concerning the provision of combustion air and general heater ventilation.

Where a heater is installed in room sealed mode (ie where both the flue exit and combustion air are positively connected to atmosphere) then there is no specific requirement for combustion air ventilation. However, depending upon location, provision for general ventilation may still be a necessity.

If the heater is installed in flue only mode and directly within the heated space and where that heated space has a natural ventilation rate greater than 0.5 air changes per hour then combustion air and general heater ventilation is probably not required. If the heated space has a natural ventilation rate of less than 0.5 air changes per hour then either natural ventilator openings or mechanical ventilation will be required. Please consult the installation manual for further details.

Installation Clearances Particular clearances may be necessary for the correct and safe function of the heater as well as for maintenance purposes. Such clearances are confirmed in the relevant installation manual.

Flue Powrmatic NVS heaters can be installed in either room sealed or flue only mode. Each heater requires a separate flue and/or combustion air intake system of the appropriate size and type. Installers are reminded that type approval has been granted for these appliances on the basis that they are fitted with Powrmatic NV flue systems. Maximum lengths apply and should be strictly observed.

Systems may be installed in either the horizontal or vertical plane. In either case the number of bends kept to a minimum and regard must be given to the reduction in permissible length with the addition of each bend.

The flue must be adequately supported and terminated with the approved terminal assembly, with due regard to the point of exit and it's proximity to any windows, doors or ventilation intakes etc

Condensate Powrmatic NVS heaters continuously produce condensate during their operation. The condensate drain at the rear of the unit must be fitted with a trap, the outflow of which is piped to a suitable drain or disposal point. Full details regarding this are given in the Installation and Servicing instructions.

Pipework Care should be taken when sizing pipework to ensure that minimum gas pressures are not compromised under dynamic load conditions. Isolating valves and service unions should be provided for each heater and pipework installed with due regard for relevant standards and Codes of Practice.

Guarantee

Powrmatic heaters are provided with a comprehensive guarantee covering both the heater and the heat exchanger. For United Kingdom sales the heater has the benefit of a two year parts and labour guarantee whilst the heat exchanger assembly has a **ten year** time related warranty. All guarantees are subject to terms and conditions.

Powrmatic pursues a policy of continuous improvement in both design and performance of its products and therefore reserves the right to change, amend or vary specifications without notice. Whilst the details contained herein are believed to be correct they do not form the basis of any contract and interested parties should contact the Company to confirm whether any material alterations have been made since publication of this brochure.

